

**A study on the feasibility of measures relating to the
protection of pedestrians and other vulnerable road
users – Final report**

**by G J L Lawrence, B J Hardy, J A Carroll, W M S Donaldson, C Visvikis
and D A Peel**

EC Contract No. FIF.20030937

PROJECT REPORT

**A STUDY ON THE FEASIBILITY OF MEASURES RELATING TO
THE PROTECTION OF PEDESTRIANS AND OTHER VULNERABLE
ROAD USERS – FINAL REPORT**

Version: Final

by **G J L Lawrence, B J Hardy, J A Carroll, W M S Donaldson, C Visvikis
and D A Peel (TRL Limited)**

**Prepared for: Contract Number: FIF.20030937 - A study on the feasibility of
measures relating to the protection of pedestrians
and other vulnerable road users**

**Client: European Commission, Enterprise
Directorate-General, Automotive Industry**

Copyright TRL Limited June 2004

This report has been prepared for the European Commission, Enterprise Directorate General, Automotive Industry. The views expressed are those of the authors and not necessarily those of the European Commission.

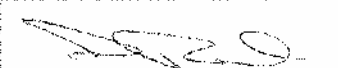
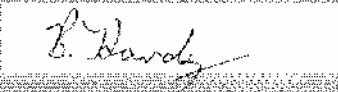
Approvals	
Project Manager	
Quality Reviewed	

This report has been produced by TRL Limited, under a Contract placed by the European Commission. Any views expressed are not necessarily those of the European Commission.

TRL is committed to optimising energy efficiency, reducing waste and promoting recycling and re-use. In support of these environmental goals, this report has been printed on recycled paper, comprising 100% post-consumer waste, manufactured using a TCF (totally chlorine free) process.

CONTENTS

1	Introduction	1
2	Overview of current research and development	3
2.1	Concept of passive pedestrian protection	3
2.2	Pedestrian protection in the bumper area	4
2.2.1	The bumper tests	4
2.2.2	Current position on providing protection – bumper area	5
2.2.3	Summary of protection in the bumper area	8
2.3	Pedestrian protection in the bonnet leading edge area	8
2.3.1	The upper legform tests	8
2.3.2	Current position on providing protection – bonnet leading edge area	8
2.3.3	Summary of protection in the bonnet leading edge area	12
2.4	Pedestrian protection in the bonnet area	12
2.4.1	The headform tests	12
2.4.2	Current position on providing protection – bonnet top and supporting areas	13
2.4.3	Summary of protection in the bonnet area	15
2.5	Euro NCAP pedestrian test data	15
2.6	Research vehicles	16
2.7	Conclusions from current research and development	17
3	Alternative test methods and tools (review of state of development and availability)	18
3.1	Alternative test tools	19
3.1.1	Legform	19
3.1.2	Upper legform impactor	24
3.1.3	Headform	24
3.1.4	Pedestrian dummy	26
3.2	Alternative test methods	27
3.2.1	Legform test method	27
3.2.2	Upper legform test method	28
3.2.3	Headform test method	28
3.2.4	Hybrid-test	34
3.3	Proposed refinements to the EEVC test methods and criteria	34
3.3.1	Legform test	35
3.3.2	High bumper test	42
3.3.3	Upper legform test	44
3.3.4	Headform test	51
4	Assessment of the development and availability of new technologies	52
4.1	Technology already in use	52
4.1.1	Passive protection	52
4.1.2	Active protection	52
4.2	Technology designed for use on new vehicles	54
4.3	Technology under development	56
4.3.1	Active protection	56
5	Comparison of protection levels	58
5.1	Non-deploying passive systems	58
5.1.1	Results for the Honda Civic	58

5.2	Deploying systems	59
5.2.1	The trigger mechanism	60
5.2.2	Examination and testing of the deployment mechanism	67
5.2.3	Impact testing of the deployable system	68
5.2.4	The real-life fitness of the deployable device	71
6	Review of reliability of new technologies	72
6.1	System functional description	72
6.1.1	General system definition	72
6.1.2	Brief component functional description	73
6.2	Mode of operation	74
6.3	Failure modes	74
6.3.1	Bumper sensor assembly	75
6.3.2	Electronic control unit (ECU)	75
6.3.3	Deployable bonnet actuator	76
6.3.4	Bonnet hinge release mechanism	76
6.3.5	Electrical cable connection	76
6.3.6	Deployment algorithm	76
6.4	Failure mode assessment	77
7	Review of technical restrictions	84
7.1	Input from vehicle manufacturers	84
7.2	Design conflicts	84
7.2.1	Damageability tests	84
7.2.2	Occupant protection crash tests	86
7.2.3	Other vehicle requirements	87
7.2.4	Cosmetics	91
7.2.5	Approval and conformity of production	91
7.2.6	Restrictions due to overlapping test zones	93
7.2.7	Limitations of deployable systems and conflicts with surfaces that remain	94
7.3	Discussion of feasibility	96
7.4	Implications of feasibility issues for the Directive	97
7.4.1	Improvements to the test methods and changes for feasibility	98
8	Review of system costs	104
8.1	Estimating the changes needed	105
8.1.1	Legform to bumper	105
8.1.2	Upper legform to bonnet leading edge	107
8.1.3	Headform to bonnet top	109
8.2	Protection features	110
8.2.1	Landrover Freelander – modifications	110
8.2.2	Landrover Freelander – pedestrian impact cost implications	122
8.2.3	Ford Mondeo – modifications	144
8.2.4	Ford Mondeo – pedestrian impact cost implications	155
8.2.5	Pop-up bonnets	172
9	Review of manufacturing costs	173
9.1	Cost for a typical vehicle	173
9.1.1	Supermini	174
9.1.2	Small family car	174
9.1.3	Large family car	174

9.1.4	Executive car	175
9.1.5	Roadster	175
9.1.6	Small MPV	175
9.1.7	Large MPV	176
9.1.8	Small off-roader	176
9.1.9	Large off-roader	176
9.2	Breakdown of the European fleet	177
9.3	Costs for different combinations of solutions	178
9.3.1	Whole fleet protected without the use of deployable systems	179
9.3.2	Deployable bonnet	179
9.3.3	Attribution of the costs for bolt-on spoilers	179
9.3.4	Deployable bonnets and no off-roader spoiler costs	179
10	Cost benefit analysis	181
10.1	Overall methodology of cost benefit study	182
10.2	Calculations and results	183
10.2.1	Vulnerable road user casualties in the European Union	183
10.2.2	Proportions hit by car fronts	185
10.2.3	IHRA pedestrian accident dataset	185
10.2.4	Injury risks	186
10.2.5	Brake assist systems	187
10.2.6	Methodology for proportions hit at survivable speeds	189
10.2.7	Obtaining proportions hit by test area and at survivable speeds	192
10.2.8	Numbers of casualties ‘saved’	194
10.2.9	Financial benefits of casualties ‘saved’	194
10.2.10	Costs of protecting vulnerable road users	196
10.3	Discussion of cost benefit study	197
11	Summary of possibilities and recommendations	201
11.1	Legform test	202
11.2	High bumper test	203
11.3	Upper legform test	204
11.4	Child and adult headform test	205
11.5	Cost benefit	207
11.6	Relaxation of protection verses benefits of brake assist	208
11.7	Protocol for deployable (contact or pre-contact) systems	208
11.8	Small series production	209
11.9	Vehicle parts not covered by phase two	210
	Acknowledgements	211
	References	212

1 Introduction

In most countries, including those of the European Union, pedestrians and other vulnerable road users form a significant proportion of all road user casualties. Research has shown that measures to improve car design, to mitigate pedestrian injuries in collisions, can be very effective in reducing the number of fatalities and serious injuries. Therefore the European Commission supported the development of test methods and test tools suitable for requiring certain standards of pedestrian protection. These test methods were first developed by the European Enhanced Vehicle-safety Committee Working Group 10 (EEVC WG10) and then further refined by EEVC Working Group 17 (EEVC WG17). The European Union has been considering requiring car manufacturers to comply with these test methods for some time, however, providing pedestrian protection will require significant changes to the way cars are made, both to the outer skin and to some parts of the underlying structure.

Most experts agree that requiring full compliance with EEVC WG17 in one step would be too demanding. As a result, car manufacturers and others (including EEVC WG17) have suggested that some form of phasing in of the pedestrian protection requirement would be more reasonable. Therefore, following consultation with those concerned, the European Commission and the main car manufacturers associations that supply cars to the European market (ACEA, JAMA and KAMA), developed a two-stage approach. The first stage required pedestrian protection to be provided in new car designs using an adaptation of the EEVC WG17 test methods that are somewhat less demanding. Following a feasibility assessment study, a higher level of pedestrian protection could be provided by a second phase. The car manufacturers offered to commit themselves to meeting these protection requirements without legislation. However, the European Parliament decided, in their resolution of 13th June 2002, that a Directive should be drafted to require protection. Therefore a draft Directive laying down the application dates, the goals to be achieved and the methods to monitor their application, based on the commitment made by the industry including the feasibility assessment of the second phase, was produced by the Commission. The Directive 2003/102/EC was approved by the European Parliament and by the Council on the 17th of November and published in the Official Journal of the European Union on the 6th of December 2003 (European Parliament and Council of the European Union, 2003).

In parallel with the above process, the European Commission produced a specification for the feasibility study for the second phase of the Directive (the Directive has a commitment to have independent experts carry out such a study by 1st July 2004). TRL Limited were subsequently contracted to carry out this the feasibility study over the period 18th December 2003 to 9th June 2004. This report describes the findings, recommendations and conclusions of the feasibility study.

The second phase of the EC Directive consists of three principal test procedures each using different sub-systems impactors to represent the main phases of a car-to-pedestrian impact. The three impactor types are:

- A legform impactor representing the adult lower limb to indicate lateral knee-joint shear displacement and bending angle, and tibia acceleration, caused by the contact of the bumper.
- An upper legform impactor representing the adult upper leg and pelvis to record bending moments and forces caused by the contact of the bonnet leading edge.
- Child and adult headform impactors to record head accelerations caused by contact with the bonnet top.

Each impactor is propelled into the car and the output from the impactor instrumentation is used to establish whether the energy absorbing characteristics of the car are acceptable. The whole area of the bumper, bonnet leading edge and bonnet top likely to strike pedestrians can be assessed by carrying out several tests with each impactor, see Figure 1.1.

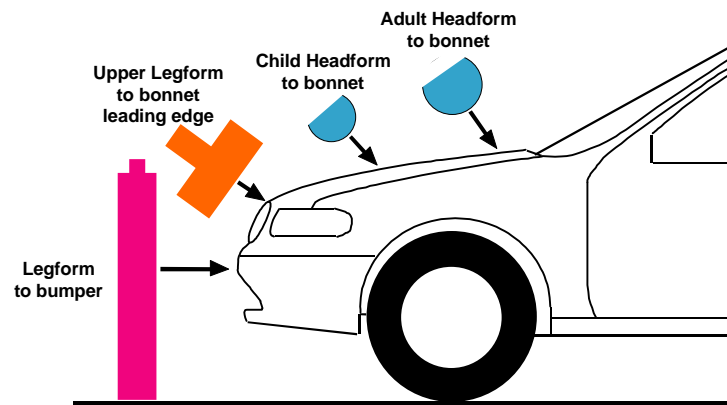

Figure 1.1. The sub-systems tests used in the second phase of the EC Directive

These test methods replicate an impact with a pedestrian and for the bumper and bonnet leading edge tests they represent the statures more vulnerable to injury (adults). Measures introduced to protect pedestrians will also be of benefit to other vulnerable road users, particularly for pedal cyclists. It is for this reason that vulnerable road users are included in the title of the EC Directive.

2 Overview of current research and development

To carry out this study TRL contacted the following associations to obtain information on the current position of research and development regarding pedestrian protection pre-accident (active) and in-accident protection (passive). As the expressions ‘active’ and ‘passive’ are often used in a different context to that given in the previous sentence, a more detailed definition of the use of these words in this report is given in Section 4.

- The association representing the European, Japanese and Korean motor vehicle manufacturers (ACEA, JAMA and KAMA respectively)
- The association representing the European tier one automotive suppliers (CLEPA)

TRL also:

- had discussions with industry and supplier experts
- undertook examination of known ‘good’ cars
- used their existing knowledge and experience gained in testing and developing improved protection

It was found that currently effort is mostly concentrating on meeting phase one of the EC Directive (European Parliament and Council of the European Union, 2003).

2.1 Concept of passive pedestrian protection

In general, the approaches used for passive pedestrian protection (deploying and non-deploying) may be simplified into three key considerations, crush depth, stiffness and force distribution. For the headform impactor the HIC criterion is a complex calculation but it is a function of force and duration. The force criterion for the upper legform can be applied directly to the maximum stiffness of the car structure, and the legform acceleration and knee shear displacement can also be converted into an equivalent force if a value for the effective mass of the legform, with its deformable knee, is estimated. Therefore to absorb the kinetic energy of the impactor, crush depth and appropriate vehicle stiffness are necessary. However, the additional criteria of bending moment and knee bending angle for the upper legform and the legform impactors respectively also place requirements on the distribution of force along the length of the impactor.

To simplify the arguments below, first only the crush depth and stiffness are considered. It is clear that the distance from the outer surface of the vehicle to any hard immovable objects must be sufficiently big to allow absorption of the energy of the impact. This depth, the crush depth, along with appropriate crush stiffness can then be used to absorb the energy of the impact. The efficiency with which the energy is absorbed is dependent on the level of contact force the vehicle structure exerts on the pedestrian test tool throughout the impact. As discussed above, to meet at least one of the performance criteria for each tool this force must not exceed a certain value. Ideally, to absorb the energy efficiently the car must exert a force, just below that required by the criterion for that tool, throughout the impact. If the impacted area is too stiff then it will fail the test. If it is too soft then it will require a larger crush depth than the minimum necessary to meet the criterion. In practice most vehicle structures that pass the test will provide a varying force level throughout the impact, meaning that the efficiency of energy absorption will also vary throughout the impact. Therefore, depending on the average or overall energy absorbing efficiency that can be achieved in practice with the car structure, larger crush depths will be necessary than the theoretical minimum. For the legform and the upper legform the impact will be approximately normal to the surface, so that the estimates of the necessary crush depth can be calculated using the appropriate impactor criteria and an energy absorption efficiency factor. For the headform test, depending on the local angle of the bonnet, the impact will often not be normal to the surface; in this case a reduced crush depth will be required, as illustrated in Figure 2.1.

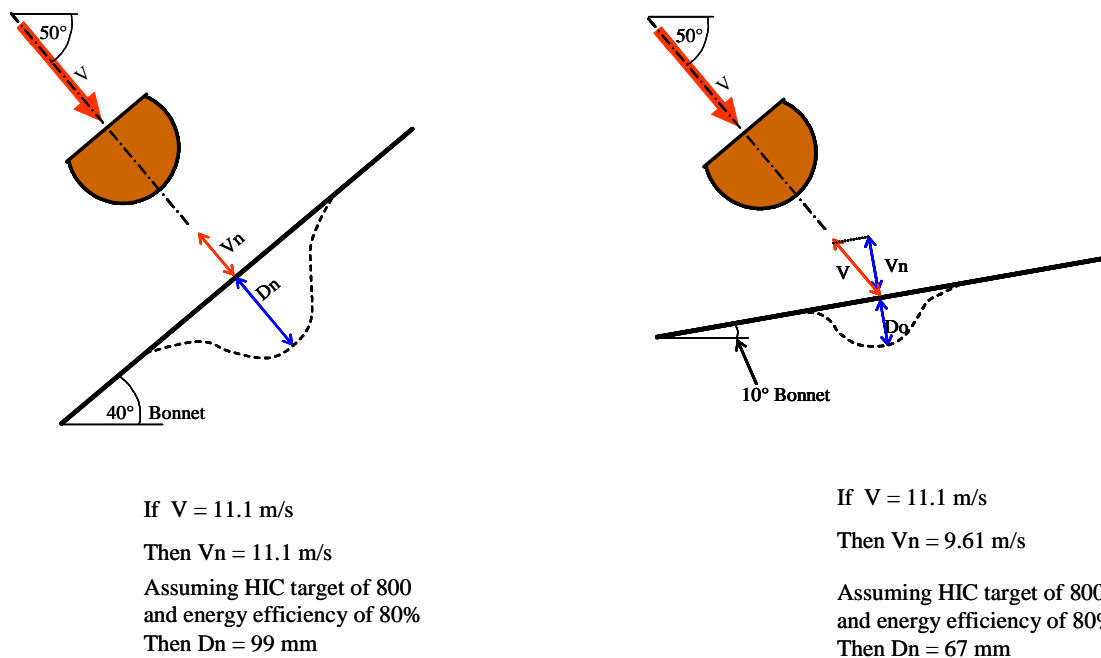

Figure 2.1. Reduced crush depth due to non-normal headform impact (child)

Through tailoring of the stiffness and crush depth of the vehicle and taking into account absorption efficiency those impactor criteria relating to force can be complied with.

Complexity is added for the upper legform and legform impactor where the force distribution along the length of the impactor must also be controlled. To control the knee bending angle for the legform, the contact forces at the bumper, spoiler and possibly the bonnet leading edge need to have appropriate stiffness and relative position. For the upper legform the force must be distributed to some degree along the length of the femur section.

2.2 Pedestrian protection in the bumper area

2.2.1 The bumper tests

The bumpers of most vehicles are at such a height that they contact the average adult leg below the knee. Current cars with this height of bumper are likely to fracture the leg bones below the knee (the tibia and fibula) in moderate to severe accidents. The tibia acceleration limit in the legform test is aimed at saving these fractures by requiring that the bumper deforms, however, without additional measures this would result in a switch to injuring the knee joint instead. Therefore, although knee joint injuries are currently infrequent, the legform impactor also has a representation of the knee joint to replicate the knee in a side impact and outputs that measure the risk of knee joint injury. The combination of the tibia acceleration, knee joint bending and knee shear displacement measurements with their performance requirements in the second phase of the EC Directive is the means of requiring protection and preventing a switch in injury patterns from lower leg fractures to knee joint injuries.

Some off-road type vehicles have bumpers so high that they contact the average adult at or above the knee and in this case the upper legform impactor is a more appropriate test tool. However, a high bumper that is safe for the femur (meets the upper legform to high bumper protection requirement) is still likely to injure the knee joint. Knowing that the upper legform to high bumper test requires more crush depth than the legform test and that, although less appropriate for high bumpers, the legform impactor is very likely to fail a dangerous high bumper, EEVC WG17 decided to retain the option for high bumpers to be tested with the legform impactor. The reasoning for allowing either test was that a

high bumper that passed the legform test was overall less likely to result in disabling injuries than one that passed the upper legform test, because bone fractures (away from joints) are less likely to result in disablement than are serious joint injuries. This combined with the assumption that manufacturers would normally opt for protection that requires less crush depth would encourage manufacturers to design to meet the legform test rather than the upper legform test and therefore result in more pedestrian friendly designs.

2.2.2 Current position on providing protection – bumper area

The current solutions for bumpers are aimed at meeting phase one of the Directive or to achieve some points in the European New Car Assessment Programme (Euro NCAP). However, as the only difference between phase one and phase two of the Directive is a reduction in the maximum permitted tibia acceleration and lateral knee bending angle (with the same knee shear limit in both phases) it can be concluded, with some caution, that all that is needed to meet phase two is a more thorough application of the same protective principles. (Euro NCAP also uses the phase two Directive tests (Euro NCAP, 2003).)

Current plastic bumper faces are already highly flexible and need no significant change or development in their ability to deform. Therefore, the properties and the solutions needed to meet the requirements of both phase one and phase two of the Directive are:

- Sufficient crush depth:
 - Many current cars have insufficient crush depth to meet the pedestrian protection requirements.
 - Additional crush space is being released by moving the hard bumper beams back or by making them stronger and thinner. Alternatively thinner and weaker bumper beams can be used with an additional link between the chassis rails, in front of the sub frame for example, to maintain the necessary link between the chassis rails needed to provide offset frontal crash performance. However, this is complicated by a combination of factors which are discussed in Section 7.
- Appropriate deformation stiffness:
 - Current bumper faces without pedestrian protection may be too soft without additional energy absorbing material behind.
 - Additional energy absorbing material is often used to enhance crash protection and insurance ratings. The width, height and stiffness of energy absorbing material are now being optimised to meet the pedestrian legform impactor acceleration criterion. That is, for the deformation stiffness to give a tibia acceleration within the maximum permitted tibia acceleration criterion even if the distance between the bumper face and immovable objects behind is limited.
- Appropriate force distribution:
 - Currently most bumper profiles are deep (top to bottom edge) and include an integrated air-dam or spoiler. In normal modern cars, these spoilers are set behind the main bumper face but are less evident with older designs of cars that also had narrow bumpers. The deep bumper and air-dam or spoiler styling changes are beneficial in distributing the contact force onto the pedestrian and the legform impactor.
 - Therefore, only small changes in bumper shape and spoiler position are needed from current styles and this is particularly true for the bumpers of the sports version of saloon cars.

- The other important quality of a bumper to control the force distribution on the leg is the distribution of stiffness in the bumper from the top to the bottom edge.
 - The change found here is a general stiffening of the lower edge either by minor changes to an existing under-tray or splash guard or by introduction of a support bar. However, it is possible to make the lower edge of the bumper too strong, which would result in unnecessary injuries at about ankle level in real life. Unfortunately, the legform test does not detect excessive lower edge stiffness, nevertheless some manufacturers have already identified this risk from their simulation results and are limiting bumper lower edge stiffness to safe levels; this is discussed further in Section 7.

A method of managing the energy resulting from an impact to the bumper that is currently employed by one vehicle manufacturer employs a combination of deforming loop and crush cans on the front face of the bumper armature at each end where it is attached to the main chassis rails. This arrangement consists of a two-stage energy management system. A loop of metal strip in front of a rectangular crush can section absorbs energy during a pedestrian legform impact by a rolling plastic bending mode with the deformed loop material going into the hollow centre of the rectangular section as it is pushed back. The stronger rectangular section (crush can) has an indented crease around it that allows it to crush at higher loads than generated in a pedestrian leg impact. Un-deformed, there is a small gap between the plastic bumper facia and the metal loop, the facia only contacts the metal loop during an impact. A different solution was used for the central area of the bumper of this car where a large crush depth (larger than the minimum required by the acceleration criterion) was combined with a low bumper stiffness to allow the leg to penetrate the bumper and engage the spoiler and bonnet leading edge, thus distributing the contact force. The results from legform tests to the Honda Civic (Lawrence *et al.* 2002) are shown in Table 2.1 with the impact points identified in Figure 2.2. Figure 2.3 shows these points in relation to the underlying structures of the bumper. Figure 2.4 shows pre-test and post-test images of the deformable loop and crush can combination, with the loop clearly deformed following the test.



Figure 2.2. Legform test sites



Figure 2.3. Underlying points for the legform impactor tests

Table 2.1. Legform test results

Test point	Location ‡	Impact velocity (m/s)	Knee angle (°)	Shear displacement (mm)	Tibia acceleration (g)
L01	Over left strut, 477 mm from C/L	11.11	15.1	4.6	164
L02	218 mm to left of C/L, midway between verticals at centre & corner of headlight	11.13	14.4	1.9	112
L03	1 mm to right of centreline	11.13	9.0	2.2	102
L04	Just off the inner corner of the headlight, 386 mm to right of centreline	11.12	15.8	2.7	181

‡ Dimensions are target locations, not necessarily precisely the actual impact locations.

Undamaged right hand crush loop



Damaged left hand crush loop



Figure 2.4. Bumper armature damage post test, L01

It is clear that other manufacturers are also using, or considering using combinations of shape and stiffness to provide leg protection. For example, the new Volvo S40 has a thinner high-strength bumper beam combined with improved bumper and spoiler shapes, with the spoiler positioned more forward than normal. These are combined with a deformable plastic box behind the bumper fascia and an energy-absorbing under-tray (closure) to support the spoiler. It is understood from discussion with Volvo that the aim of these and other changes was to provide as much pedestrian protection as possible within the constraints of carry-over features in the underlying platform and to achieve a good performance.

2.2.3 Summary of protection in the bumper area

The study has shown that car manufacturers and some of their tier one suppliers understand well the protective principles for the legform to bumper test. They are now actively working to provide the correct combination of compliance in the bumper to control tibia acceleration and knee joint shear to meet the phase one requirements of the Directive. The shape and stiffness profile of the bumper and spoiler are being used to control the force distribution on the legform, which in turn limits the lateral knee bending angle. Finite element simulation and component testing are being used to help understand and refine the pedestrian protection properties of the vehicle and determine the interaction between pedestrian protection features and styling, functionality and crash protection. In proposing the protection standards now enshrined in phase one of the Directive it appears reasonable to conclude that vehicle manufacturers consider protecting to phase one to be feasible (if demanding). It has also been concluded, with some caution, that all that is needed to meet phase two is a more thorough application of the protective principles found to meet phase one; however, this may raise some feasibility issues which are discussed in Section 7.

2.3 Pedestrian protection in the bonnet leading edge area

2.3.1 The upper legform tests

For a given speed in an impact between a vehicle and a pedestrian, the severity of the contact between the bonnet leading edge (BLE) and the part of the pedestrian's body hit, in terms of change in velocity, angle of contact and pedestrian effective mass is dependent on the shape of the vehicle. For streamlined car shapes the impact will be of low severity and for tall upright shaped cars the impact will be of higher severity. In order to simply reproduce this effect in the upper legform to bonnet leading edge test, three look-up graphs are used so that appropriate test velocity, energy and impact angles can be looked up for the shape of vehicle under test. Energy and velocity are specified rather than mass and velocity because it is easier to define the test severity precisely in this way (the impactor mass is then calculated from velocity and energy).

The combination of both femur bending and total force measurements and their performance requirements in phase two of the Directive is the means of requiring protection for both the femur and pelvis.

2.3.2 Current position on providing protection – bonnet leading edge area

In phase one of the Directive the bonnet leading edge has target performance values rather than mandatory maximum values, combined with monitoring of results. Therefore, in the short term there is less pressure for manufacturers to improve this area.

The properties and the solutions needed to meet the requirements of phase two of the Directive are:

- Sufficient crush depth:
 - Strictly speaking there is sufficient room for the bonnet leading edge to deform in most current cars for them to meet the pedestrian protection requirements before

contact is made with immovable objects such as the engine. However, in practice the combined strength and positions of the following features all combine to restrict crush depth:

- Rigid mounting required for vibration free headlamps.
- The upper cross-member which includes the bonnet lock and upper fixing for the cooling pack and forms the necessary link between the upper load paths in the inner front wing area.
- The strength and positioning of components such as the headlamps and radiator.

Some manufacturers have started to release additional crush space by moving back the upper cross-member and bonnet support buffers leaving the bonnet front edge free to deform. However, this is complicated by a combination of factors which are discussed in Section 7.

- Appropriate deformation stiffness:
 - Currently the bonnet leading edge may be too strong because it is shaped so that it is loaded in its strongest mode and also receives support from the upper cross-member, as illustrated in Figure 2.5. To address this, changes in styling are being used;
 - By adopting a more curved shape on the front edge of the bonnet a more gentle transition between the bonnet top and the front face of the vehicle may be achieved. This, along with a smaller distance between the outer surface and the inner under frame of the bonnet and moving back the upper cross-member all means that the tested area of the bonnet is more easily deformed, see Figure 2.6.
 - Alternatively, within the overall vehicle shape the plastic front face components (bumper, headlamp, grill and grill surround) are being extended more rearwards so that the opening bonnet edge is tending to be behind the upper legform test area with the main test area being to a relatively soft plastic front nose. This type of styling feature can be seen in the new Volvo S40, see Figure 2.7. The two BMW models that are shown in Figures 2.8 and 2.9 also show this change in style with the older 5 Series having an extended metal bonnet forming a metal nose and the more recent 6 Series having a plastic nose. These changes in styling are not thought to be driven by pedestrian protection but they could be used to help meet the pedestrian protection requirements. It is possible that this styling trend could be taken further if necessary to move the metal parts further away from the legform and upper legform test area. This has been illustrated by adding a red-line on the photograph of the BMW 6 Series to indicate a new more rearwards switch from plastic to metal parts, see Figure 2.10.

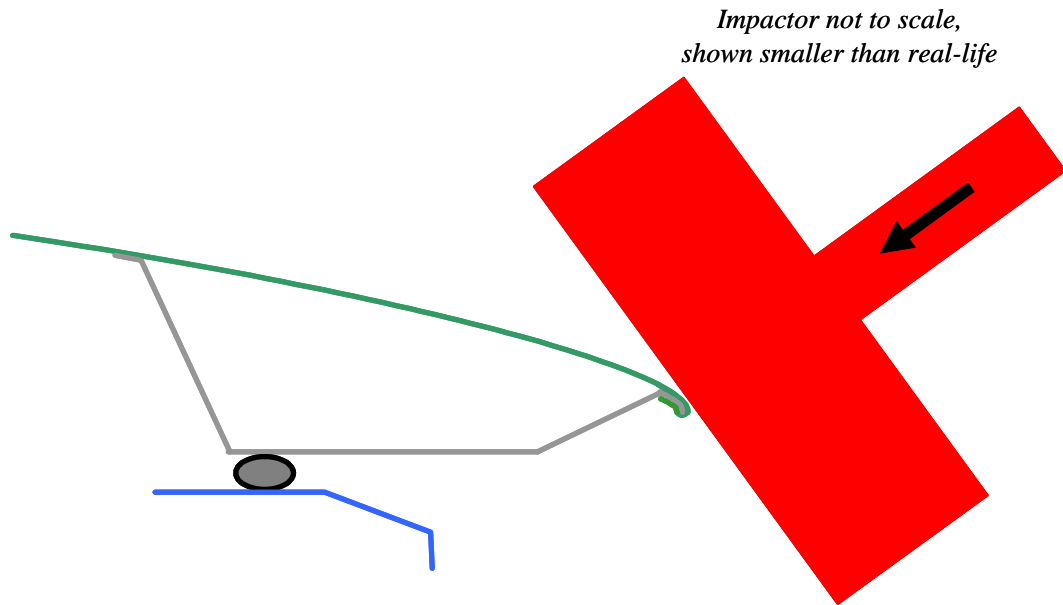

Figure 2.5. Typical current bonnet leading edge

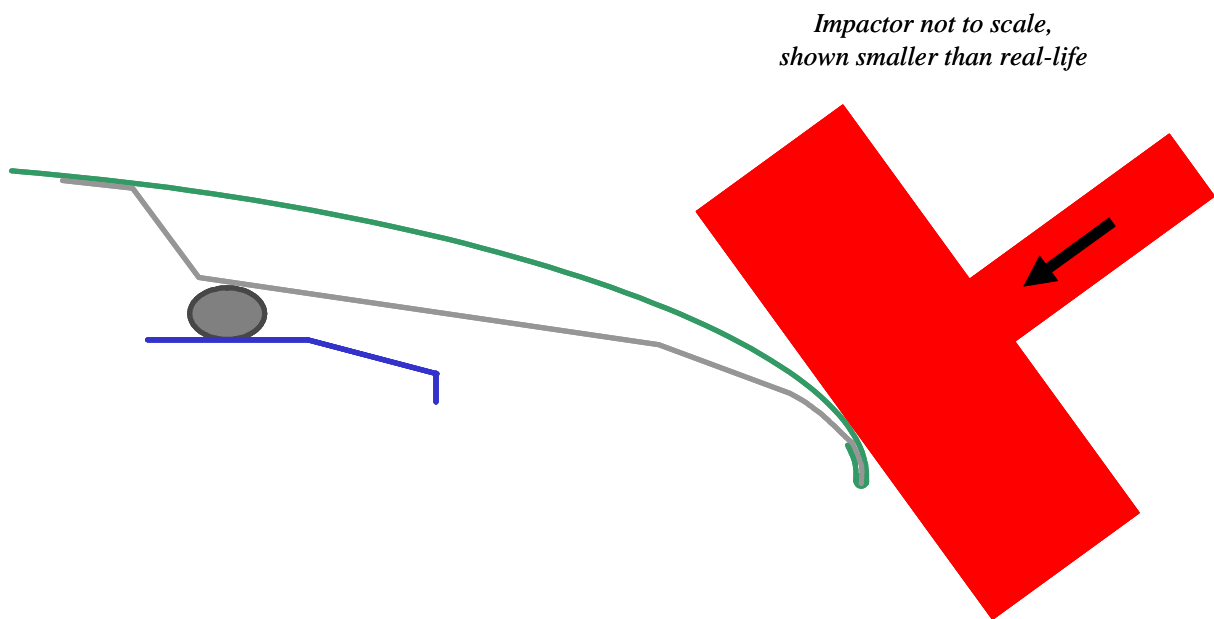

Figure 2.6. Typical bonnet leading edge with pedestrian protection



Figure 2.7. Volvo S40, with plastic front face components extending into the conventional 'bonnet' surface



Figure 2.8. Changes in styling - older style BMW 5 Series with steel bonnet leading edge



Figure 2.9. Changes in styling – new style BMW 6 Series with bumper/grill extending into bonnet, with more rounded edge



Figure 2.10. Possible adaptation or enlargement of styling change by extending plastic parts back towards red-line

- Depending on the styling of a vehicle, the headlamp 'glass' may effectively form the outer bonnet leading edge or the complete light units may support the front edge of the bonnet. These can be adapted to deform by the use of plastic in place of the glass

and the lamp housing can be made deformable or frangible. Examples of this can be seen in the Honda Civic and the Volvo S40.

- Bonnet leading edge to upper legform force distribution:
 - As with providing the ability to deform, changes in styling are being used to control the force distribution
 - By providing greater radii of curvature for the shape on the front edge of the bonnet, it means that the force of the impact can be better distributed and the necessary crush depth reduced.

2.3.3 Summary of protection in the bonnet leading edge area

From the investigations for this study, it has been found that car manufacturers have tended to put less work into considering the upper legform to bonnet leading edge test than for the legform or headform tests. Perhaps as a result of the target, rather than mandatory, requirements in phase one of the Directive, the reaction to the potential requirements is certainly less measured for some manufacturers than it is for the legform to bumper test. Whilst it appears that experimental and numerical simulation work is occurring to cover the bonnet leading edge area, it is apparent that the manufacturers believe the requirements of phase two of the Directive are unfeasible. There will always be a battle in the bonnet leading edge area to marry the reduced stiffness of structures required for the pedestrian test with the structural rigidity necessary at joints in this area and these feasibility issues will be discussed in Section 7. Another approach is to increase the bonnet leading edge clearance from underlying structures by raising it; however, this requires greater impact energy, according to the current look-up tables in the test procedure and therefore does not offer an easy solution. Reduction of the impact severity through lowering the bonnet leading edge and increasing bumper lead, which results in reduction of the test energy is another strategy being considered by some manufacturers. Although this will aid compliance with the Directive phase two requirements, it will restrict the space available for cooling and the upper front cross-member, etc. The scope for design changes in this region is linked to feasibility issues and is discussed further in Section 7.

2.4 Pedestrian protection in the bonnet area

2.4.1 The headform tests

The head injury risk criteria used in this test in both the EEVC and EC Directive test methods is the 'Head Performance Criterion' (HPC). This may lead to some confusion because the most frequently used criterion for head injury risk is the 'Head Injury Criterion' (HIC). However the formula used to calculate 'HPC' is identical to that used to calculate 'HIC'. The reason for using a HPC rather than HIC within these pedestrian test procedures is so that the formula is fixed. This prevents any subsequent change to the HIC calculation method causing an involuntarily change to criterion used in these test methods. Within this report HIC and HPC mean the same thing e.g. calculated from headform resultant acceleration using the formula specified in the EC Directive.

In phase one of the Directive, the bonnet top is tested with just one type of headform. This headform represents the head of a child or small adult and has a mass of 3.5 kg. The test is performed at an impact speed of 35 km/h and the limits for passing the test are that the HPC shall not exceed 1000 over 2/3 of the bonnet test area and 2000 for the remaining 1/3 of the bonnet test area.

For phase two of the Directive two different headforms are introduced instead of that used in phase one, one of the headforms represents the head of a child (impactor mass 2.5 kg) and the other of an adult (impactor mass 4.8 kg). The headforms are used in two distinct test areas covering the bonnet top based on the stature of the pedestrians that the headforms represent. Both of the headform tests are to be performed at an impact speed of 40 km/h and the pass or fail criterion is that the HPC shall not exceed 1000 for the whole of the bonnet test area. Discussion of the justification for these tests

and potential revisions are presented in Section 3 and application of the test zones and pass or fail criterion further discussed as feasibility issues in Section 7.

To an even greater extent than was the case for the legform tests, the protection for pedestrian heads as assessed by the headform tests can be broken down into the two fundamental considerations. Firstly the stiffness of the impacted structure, the bonnet or the wing edge and secondly, the available depth to rigid underlying structures such as the engine, bulkhead / firewall and structural beams such as the upper longitudinal beam (rail).

2.4.2 Current position on providing protection – bonnet top and supporting areas

The properties and the solutions needed to meet the requirements of phase two of the Directive are:

- Sufficient crush depth:
 - Sufficient crush depth is required under the bonnet to attenuate the energy of the impactor before contact is made with immovable objects, such as the engine, bulkhead / firewall, suspension tower or underlying structural beams such as the upper longitudinal beam. There are a four basic principles that can be used for achieving the required crush depth which can be used in any combination:
 - Locally modifying the design to remove rigid high points, moving hard assemblies down or by making underlying components lower through more compact designs.
 - Modifying hard structures to make them crush, shear off, or push down on collapsible brackets.
 - By changing (raising) the bonnet line, to obtain more clearance over immovable or rigid elements, providing space into which the bonnet can deform. However, the height of the bonnet is fundamental to the styling of the vehicle.
 - By introducing deployable systems such as pop-up bonnets to increase crush depth.
- Appropriate deformation stiffness:
 - The deformation of the bonnet should be considered with regard to the underlying skin(s) and reinforcing elements:
 - The introduction of additional clearance between the inner and outer skins can tailor the stiffness of the bonnet as a whole.
 - Reinforcements under the bonnet may be made more deformable. One method for achieving this is the changing of the cross-section of the reinforcing beams (see Figure 2.11 and Figure 2.12).
 - Development of a more homogeneous bonnet support system avoiding the use of stiff reinforcement beams. Mazda Motor Corporation has developed the ‘Shock Cone Aluminium Hood’, which has a structure aimed at enhancing pedestrian protection. Instead of a framed structure, the Shock Cone Aluminium Hood has an inner panel that is shaped with numerous craters, similar to cones (Mazda, 2004).



Figure 2.11. Current reinforcement cross-section



Figure 2.12. Proposed new reinforcement with a more readily deformable cross-section

- It may be impractical to raise the bonnet level over certain features of a vehicle that are found in the engine bay, to provide sufficient crush depth. As an alternative, these features may be made to deform under loading to absorb energy. This strategy can then be used with many features that may cause high deceleration levels for a headform. The height and stiffness of deformable elements may need to be optimised to be within the maximum permitted HIC, particularly if the distance between the bonnet and immovable objects underneath is limited:
 - Fluid reservoirs may be supported by deformable brackets.
 - The wings may have deformable edge supports as opposed to strong rigid protrusions to rest on (see Figures 2.13 and 2.14).

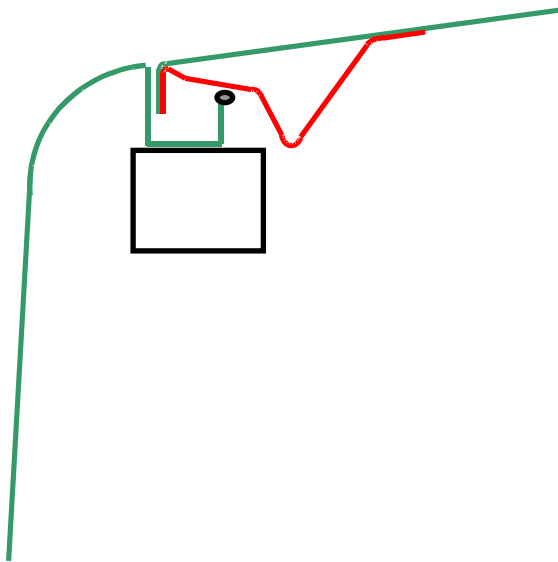

Figure 2.13. Bonnet edge with strong underlying support mounted on the wing

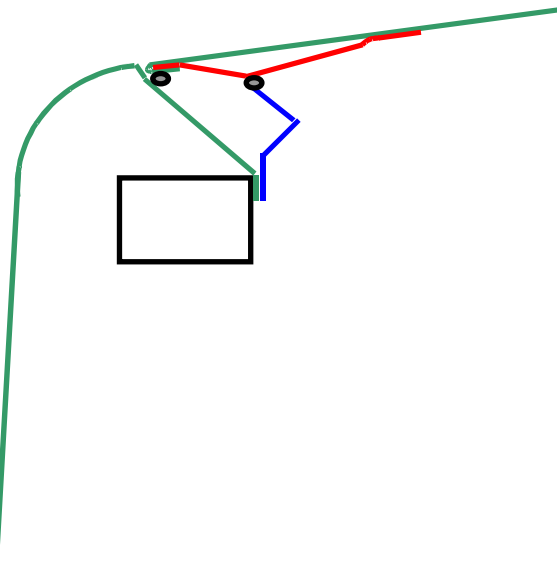

Figure 2.14. Bonnet edge with a more deformable wing support

- The bonnet hinges may be designed to deform under a head impact (see Figures 2.15 and 2.16).
- For head protection at the rear of the headform test area measures may include:
 - Adding deformable or shear-off systems for the wiper spindles and linkage.
 - Weakening of the bulkhead and firewall.

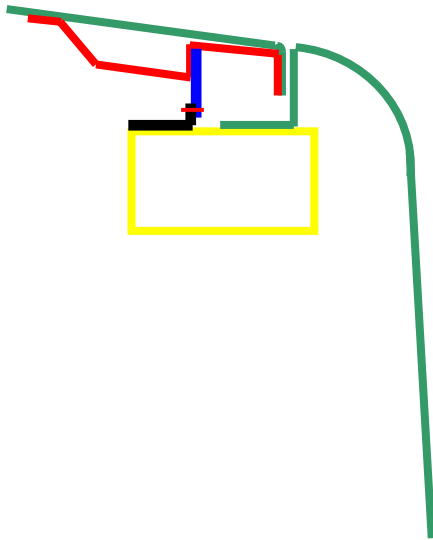

Figure 2.15. Bonnet mounted with a conventional hinge

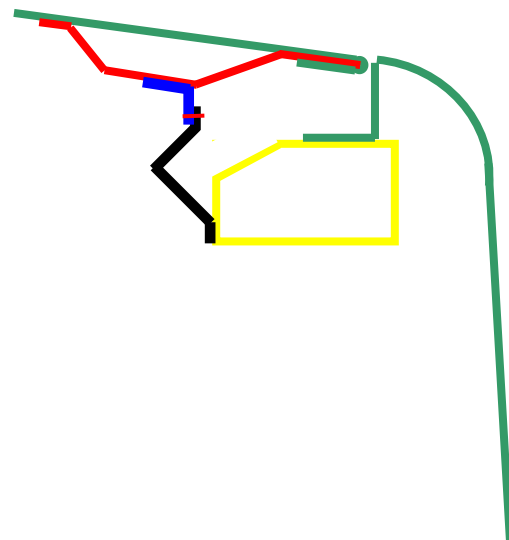

Figure 2.16. Bonnet mounted with a more deformable hinge structure

2.4.3 Summary of protection in the bonnet area

To date, the concepts described above for providing protection for pedestrian heads are thought to be at least sufficient to solve the requirements for phase one of the Directive. However, it is not clear from current data if the degree of change necessary to meet phase two of the EC Directive will be feasible for the whole of the bonnet top test area; this is discussed in Section 7.

2.5 Euro NCAP pedestrian test data

Existing pedestrian protection technology employed on current vehicle designs may have been evaluated by the Euro NCAP pedestrian assessment. The test procedures currently used in Euro NCAP pedestrian evaluations (Euro NCAP, 2003) are based on the test methods of EEVC WG17, which are the same as those specified for phase two of the EC Directive (the first Euro NCAP protocol was based on EEVC WG10). However, Euro NCAP has had to adapt the EEVC test methods so that the protection of different models can be compared by star and points ratings; the EEVC methods just give a pass or fail threshold. As well as testing the front of the vehicle up to and including the base of the windscreen as in the EEVC procedures, Euro NCAP also evaluate the performance of the windscreen, the dashboard top (through the windscreen), A-pillars and if appropriate the upper windscreen frame.

The points system used by Euro NCAP specifies a maximum number of points for each test area if the EEVC criteria are met. A maximum score in each area would result in 36 points with an award of four stars for pedestrian protection. Therefore, although the Euro NCAP protocol is not identical to that of phase two of the EC Directive, a four star car is likely to pass and a three star car is likely to be close to passing phase two of the Directive.

Examination of Euro NCAP test results shows that no car tested to date has received full marks in Euro NCAP tests for protection of pedestrians.

The Daihatsu Sirion M100LS was the first car to receive three stars, back in 2000; however, this result was partially due to the rating method used at the time, which favoured cars with short bonnets. At the beginning of 2002 the test methods were updated from EEVC WG10 to WG17 and the method of allocating points was adjusted to help separate cars that were uniformly poor from ones that were mostly good but had a few bad points. Since this change, only three cars have received three stars, the Honda CRV, the MG TF and the Volkswagen Touran.

The MG TF profited through receiving many automatic passes with the adult headform for the windscreen (assumed safe) and for the upper legform impactor tests where the car shape was such that no test was required (car shape such that no significant bonnet leading edge contact would occur in real life). The bumper of the MG TF performed particularly well although the knee bending angle did just exceed the performance criterion in one test. The MG TF also performed well in one of the child headform tests due to its rear engine layout as the impact site was on the bonnet over the spare tyre.

The Volkswagen Touran passed the legform test requirements apart from the tibia acceleration which just exceeded the limit in one test, at a location nominated by the manufacturer. The three upper legform tests all failed as did the adult headform tests, although of the 24 adult headform test sites, ten were passed automatically (directed onto the windscreen and therefore assumed to be safe). The Touran received six out of twelve for child head protection with the two manufacturer nominated sites passing and two others having HPC values of between 1000 and 1500.

These vehicles have shown that with existing technology, the requirements of the bumper as assessed by the legform impactor test method from phase two of the EC Directive can be met for most of the bumper area. The requirements for the upper legform test area appear to be more difficult to achieve when testing is required, although few manufacturers appear to have tried to improve this area. For the headform test areas, it has been shown that it is possible to design some areas that meet the requirements of phase two of the EC Directive. However, none of the vehicles have scored full marks in any one area when they have been tested. As already noted, full marks is approximately equal to passing phase two of the EC Directive.

2.6 Research vehicles

Meeting the requirements for crash safety in both frontal impact protection and pedestrian protection was an objective of the project reported by Bosma *et al.* (2001). New concepts for a vehicle front with enhanced safety features were developed and incorporated into their demonstration vehicle called the 'Ecofront'. This vehicle front consisted of a bonnet, wings and a bumper designed to satisfy the EEVC pedestrian protection requirements, whilst also taking into account styling and packaging.

A first exterior design was used to make an initial assessment of the pedestrian safety of the vehicle shape, which was performed using MADYMO multi-body techniques and MADYMO models of the EEVC pedestrian impactors. Based on the results of the conceptual studies, design recommendations were made to provide space underneath the bonnet to avoid contact with rigid engine parts and between the bumper skin and aluminium bumper. As the hinges of the bonnet normally create local stiffness in the impact zone, which makes achieving the EEVC pedestrian requirements for head impacts difficult, the hinges were placed outside of the impact area, to the sides of the A-pillars.

The bonnet was assessed through performing several child headform impact simulations. The bonnet consisted of a steel outer surface with a Bulk Moulded Compound (BMC) layer on the inside. In the area with less curvature, the stiffness of the bonnet was tuned by placing a PVC foam between the outer surface and the BMC. This produced a bonnet that for most areas achieved HIC values below 1000. An area of the bonnet produced HIC values from 1100 to 1200, which was stated as being due to the styling feature, curvature, of the bonnet in that region. By smoothing the bonnet surface, the values from this area were reduced to less than 1000.

With just the bumper skin made out of PolyPropylene (PP), it was shown to be impossible to achieve a proper balance between the bonnet leading edge, bumper and spoiler area. Therefore special energy absorbing elements, also made from PP were added behind the bumper surface. This allowed the stiffness of each of the three main areas to be tuned separately.

For all impact locations considered by Bosma *et al.*, the EEVC pedestrian requirements were found to be satisfied according to the simulations. However, the styling of their Eco-front dictated certain styling features for the vehicle, for example, having the bonnet hinges to the side of the A-pillars.

At the Institut für Kraftfahrwesen Aachen (IKA), modifications were made to an existing car to improve the pedestrian protection offered by the front of a vehicle (Kalliske and Friesen, 2001). A representative small family car was selected for the investigations. It was first tested un-modified according to the procedures proposed by the EEVC WG17 and then, based on the results, modifications were made to the vehicle aiming to improve the pedestrian protection when tested again.

In order to achieve the required deformation distance under the bonnet to absorb enough energy to pass the child and adult headform tests, the bonnet was raised, 'popped-up'. A lifting mechanism was developed by means of which the rear edge of the bonnet was actively raised, by 80 mm, in the event of an accident. As the contact sensors required to trigger the raising of the bonnet were not developed within this study, the headform tests were conducted with the bonnet already in the raised position. Additionally, the thickness of the bonnet outer surface was reduced by a third. Following these modifications, clear improvements as regards HIC values were achieved at all test locations. Two adult and two child headform test locations still failed the HIC value of less than 1000 criterion, although it was suggested that these results could be improved through better selection of the spring stiffness in the bonnet raising mechanism, particularly for the adult headform tests.

The upper legform to bonnet leading edge test area was modified by using a bonnet latch that did not prevent downwards movement of the locking bracket in the case of impact. Clear improvements were seen in the vehicle performance, although the performance criteria limits were still exceeded.

The bumper of the vehicle was brought forward by 20 mm, the standard production plastic bumper was made more elastic and a foam-core inserted between the cover and cross members. The lower edge of the bumper was brought 10 mm forward with respect to the upper edge. The shearing displacement of the knee was within the performance limit, about 4 mm for the improved vehicle. The knee bending angle was also improved but remained above the performance limit and the tibia acceleration was also above 150 g for one test.

Further revisions were made to the bumper by introducing more crush depth and stepped padding between the cover and the cross member. The three specified limit values were then found to be fulfilled.

Kalliske and Friesen (2001), in contrast to the study by Bosma *et al.* (2001), started from an existing vehicle model. It is therefore not surprising that they had greater difficulty in achieving the requirements of the EEVC WG17 test procedures. However, both studies have shown the potential to achieve the requirements in the bonnet region and the bumper. The requirements for the bonnet leading edge, according to Kalliske and Friesen, remain unfeasible.

2.7 Conclusions from current research and development

Ideally, the consultations carried out within the overview of current research and development would have provided detailed information of the position of the manufacturers with respect to meeting the requirements of phase two of the EC Directive. However, as the work in this regard is still at an early stage with the manufacturers, there was insufficient detail available to gauge the present position.

Depending on the effort made by the various manufacturers to incorporate pedestrian protection into current vehicle designs, the test results from Euro NCAP pedestrian evaluations could be used as a baseline for vehicles with little or no pedestrian protection or for some specific vehicles as an example of what can be achieved. However, unlike occupant protection, protection for pedestrians was not until recently thought to have been given high priority by most car manufacturers or car buyers. Therefore, for the results for cars without significant levels of pedestrian protection, their failure to attract a high star rating is not conclusive proof that it is difficult to achieve. Likewise, for cars that have some pedestrian protection, in the absence of a strong customer interest or legislation to drive the process, then the protection levels achieved are not proof that this is the best that can be achieved.

Research vehicles appear to show that it is possible to meet phase two of the EC Directive; however, these vehicles do not represent the full range of sizes, styles and variants now produced.

3 Alternative test methods and tools (review of state of development and availability)

The European Enhanced Vehicle-safety Committee (EEVC) set up a pedestrian working group in 1987 (EEVC WG10) and the International Organization for Standardization (ISO) set up a pedestrian working group in 1988. The EEVC and ISO working groups worked in parallel sharing some experts and information, so it is difficult to accurately credit either group with the development of the test tools and methods. However, put simply, the EEVC working group (WG10) was more active and by 1994 had developed a complete set of draft test methods and tools. EEVC Working Group 17 was set up in May 1997 to up-date and finalise the test methods and by 1998 the EEVC methods and tools were essentially complete. They consisted of separate tests to the bumper, the bonnet leading edge, and the bonnet top up to and including the base of the windscreen. These test methods, used in conjunction with their performance criteria, were drafted at the request of the European Commission in a form suitable for inclusion in a regulation to require certain standards of pedestrian protection. As a result, the EC Directive 2003/102/EC (European Parliament and Council of the European Union, 2003) currently uses the test methods drafted by EEVC Working Group 17, though most of the detail of the test methods is in a separate document (Commission of the European Communities, 2004).

To date the ISO working group have produced two test methods, one for the bumper and one for the bonnet top. The ISO test methods are very similar to the EEVC ones and in many respects they are based on them. However, they are not identical and in general the ISO test methods are less specific because they were intended for research and development rather than regulatory use. More recently, in 1997, the International Harmonised Research Activities committee (IHRA) also set up a pedestrian safety working group. The aim of this group is to build on the work of EEVC and ISO to produce improved harmonised test methods suitable for a wider range of vehicles shapes and to develop test methods and tools for all pedestrian contacts with the front of the vehicle. Some members of the IHRA group are also members of the ISO and EEVC pedestrian working groups. The EEVC methods have been limited to the front of the vehicle up to and including the base of the windscreen because these were the only areas that were thought to be feasible to improve. As the central unsupported area of the windscreen is thought to be safe this only leaves the windscreen glass close to supports, the A-pillars, the upper windscreen frame and roof, with no EEVC test method. Therefore, to meet their aim of testing all areas likely to be contacted by a pedestrian in an accident, the IHRA pedestrian working group will also need to develop test methods for these areas.

More recently, at the request of the Japan Ministry of Land, Infrastructure and Transport (Japan MLIT), the IHRA working group provided the Ministry with their best estimates of head impact conditions based on selected simulation results. The Japan MLIT, with the help of the Japan Automobile Manufacturers' Association, Inc. (JAMA) and the Japan Automobile Research Institute (JARI, who are also members of the IHRA working group), has developed a pedestrian head test method and protection requirement. The Japanese test method uses the ISO headforms and a variation on the IHRA head test method, and it will be applied to passenger cars and to trucks with GVW (Gross Vehicle Weight) ≤ 2.5 t derived from passenger cars, from 1 September 2005 for new models and from 1 September 2010 for existing models.

The UN ECE (United Nations Economic Commission for Europe) Working Party on Passive Safety (GRSP) has the task of developing a pedestrian Global Technical Regulation (GTR) based on existing research (they are doing no new research). They have proposed a head impact test procedure based on the work by JARI for IHRA and the Japanese MLIT. The GTR ad hoc group have provisionally accepted a headform test speed of 32 km/h, which the JARI simulations suggest is equivalent to a 40 km/h car impact speed, but they have asked JARI to provide more data. Their next task is to develop a legform test method for the bumper to lower leg area and this is likely to be based on the ISO or the IHRA method. However, the IHRA method is not yet fully evaluated and so is not suitable for immediate adoption by the GTR group. As the work of the GTR ad hoc group has not yet produced a final proposal, their test methods are not thought to be sufficiently complete for them to be considered at this time as suitable alternative test methods for phase two of the EC Directive.

However, as the GTR methods and tools are likely to be some form of amalgam of EEVC, ISO, IHRA and Japanese MLIT test methods, the following discussions will also provide consideration of the possible future GTR methods.

3.1 Alternative test tools

3.1.1 Legform

For evaluating car aggressiveness to the lower extremities of a pedestrian, the EC Directive specifies a legform impactor which consists of a simplified rigid femur section, a knee joint and a simplified rigid combined tibia and foot section. The specification is that developed by EEVC WG17. As part of their research work for EEVC WG17, TRL developed a legform impactor to meet this specification. The knee joint was designed to reproduce the bending moment of a human knee under lateral loading; however, the mechanism used to achieve this does not mimic a human knee. The EEVC legform and knee joint was designed to be simple, repeatable and robust and includes instrumentation that accurately measures knee shear and lateral bending. The legform, associated equipment and consumable parts have been available for several years as part of the commercial activities of TRL Limited.

ISO have produced a specification for a legform impactor, but no impactor to meet it. Therefore, as there is no ISO test tool available, it is not discussed below as an alternative test tool. However, it is interesting to note that, with the exception of the knee, the biomechanical requirements of the impactor specification are very similar to those of the EEVC.

Japanese car manufacturers and research groups JAMA and JARI have begun development of a more complex legform able to simulate the human long bone flexibility and possessing a mechanical knee joint that is a closer replication of a human knee. The latest documented version of this legform is known as the Flexible Pedestrian Legform Impactor (Flex-PLI 2003) or JAMA-JARI 2003 (Konosu and Tanahashi, 2003). As this is the only alternative legform impactor the following sections compare this impactor with the EEVC WG17 legform impactor.

3.1.1.1 Biomechanics

The long bone structure of the Flex-PLI consists of a flexible core of glass-reinforced polymer pressed between hard urethane and the core binder, which is compressed by screws through the exterior housing segments. The exterior housing segments are separated along the length of the long bone by rubber spacers. The knee joint includes simulated femoral condyles and a tibial plateau, with coil-spring tensioned wire cables representing four knee ligaments. The whole legform is enclosed within flesh that comprises a layer of rubber sandwiched between two layers of neoprene.

Dynamic three-point bending tests have been carried out to assess the biofidelity of the Flex-PLI. Direct comparison of the thigh biofidelity with that from human thigh bone tests could not be made because the PMHS (Post Mortem Human Subject) had the flesh removed before testing, however, once the flesh on the Flex-PLI was crushed the force deformation slope was of the same order as the PMHS test selected for comparison. The lower leg bone of the Flex-PLI compared well with results from three point bending tests with lower leg PMHS tests selected for comparison. A four-point loading test of the knee was used to evaluate the biofidelity of the Flex-PLI, which demonstrated a bending behaviour similar to that of the PMHS tests selected for comparison, see Figure 3.1. It can be seen from Figure 3.1 that the highest PMHS knee bending moment recorded was about 160 Nm, which is far lower than the maximum value of about 450 Nm specified by EEVC WG17 for the legform knee bending moment.

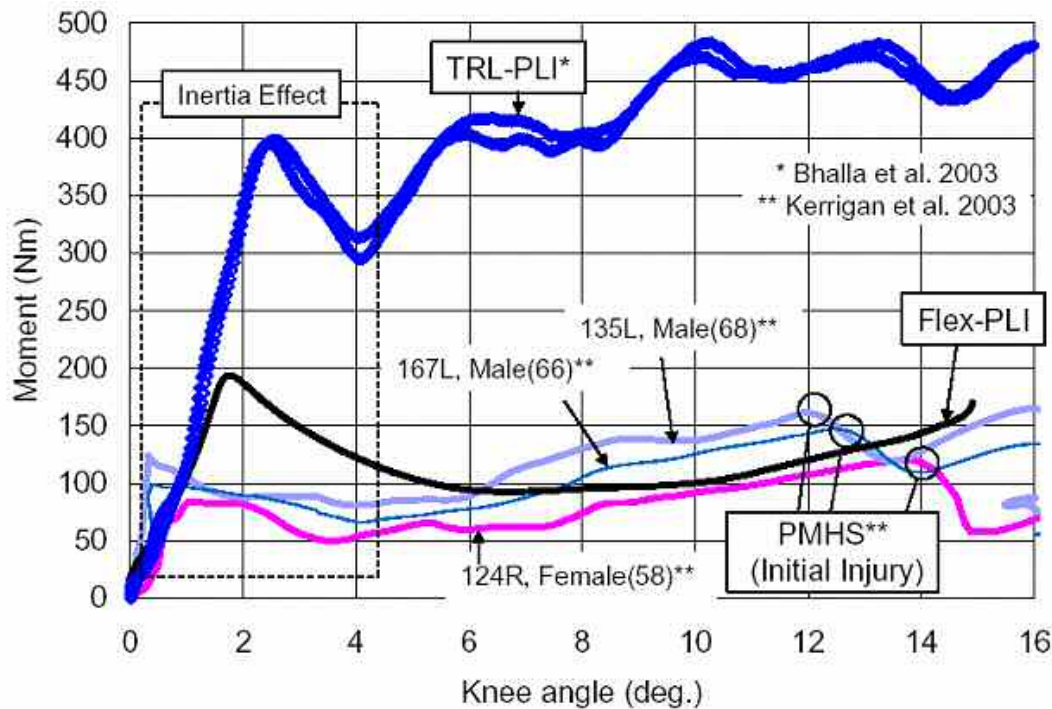

Figure 3.1. Dynamic four-point bending test for knee joint of PMHS by Bhalla *et al.* (2003) compared with similar tests of the Flex-PLI and TRL-PLI legform impactors (Konosu and Tanahashi, 2003)

There is a considerable quantity of biomechanical data for the knee joint obtained from tests of PMHS; however, the results vary widely. The cause of this variation is thought to be due to a combination of factors including the use of PMHS of elderly persons, errors due to inertial effects of moving the leg to load the knee and the visco-elastic properties of the ligaments, which result in low stiffness at low loading velocities and higher stiffness at higher velocities. In the more recent PMHS knee study used by Konosu (Bhalla *et al.*, 2003), efforts were made to isolate the lateral stiffness of the knee joint. However, the loading method forced the knee to deflect about a pre-determined plane, which would have prevented the knee joint from rotating slightly, as it would have done in real life to share the loading between the collateral and cruciate ligaments under tension; this may have resulted in a lower stiffness and premature failure. This forced knee loading was caused by the use of the rollers at each end of the sample; the line contact of the roller would have inhibited axial rotation between the tibia and femur, see Figure 3.2.

However, perhaps the most important weakness of the data based on tests of PMHS is the lack of muscle tension. In the 1994 report of EEEVC WG10 (European Experimental Vehicles Committee, 1994) biomechanical data for the knee were considered, from PMHS tests at velocities of 16 to 20 km/h that gave a knee bending moment of 120-140 Nm. They also considered results from tests on the knees of volunteers that indicated quasi-static lateral knee bending moments of 115 to 170 Nm without injury or discomfort. They concluded that these results were in conflict because the quasi-static results are on average higher than the dynamic results and the opposite should be expected due to the visco-elastic properties of ligaments. They decided that a higher knee stiffness was needed in the impactor than shown by the PMHS tests to account for higher impact velocity and the effects of muscle force. It should be noted that the muscles and ligaments from the thigh area are positioned around the knee in such a way that they would significantly increase the stiffness of the knee in lateral loading if they were tensioned. The tendons around the knee are the tendon of the Biceps muscle, which forms the outer hamstring and the tendons of the Semitendinosus, Semi-membranosus with those of the Gracilis and Sartorius, which form the inner hamstring (Gray H, 2001), see Figure 3.3.

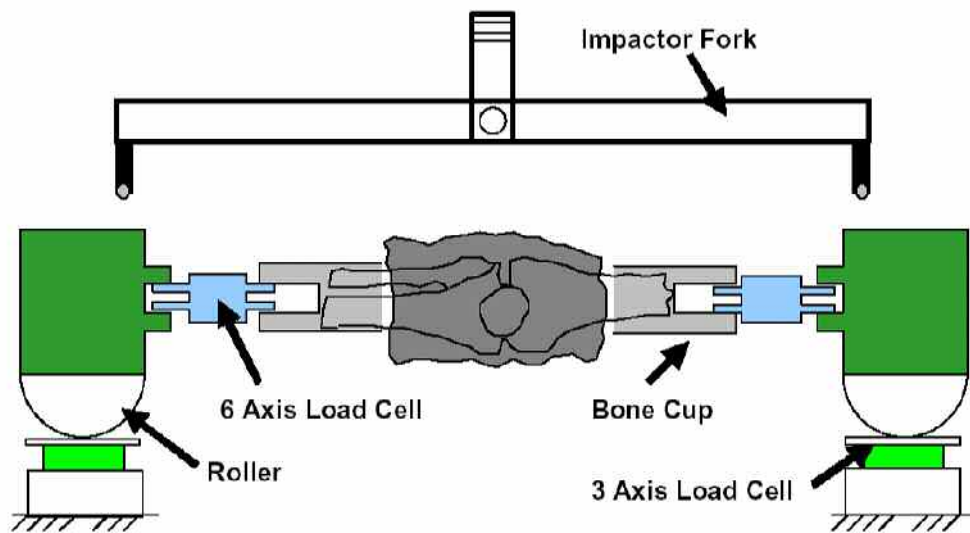

Figure 3.2. Schematic of the four-point knee bending test set up used in PMHS tests (Bhalla *et al.*, 2003)

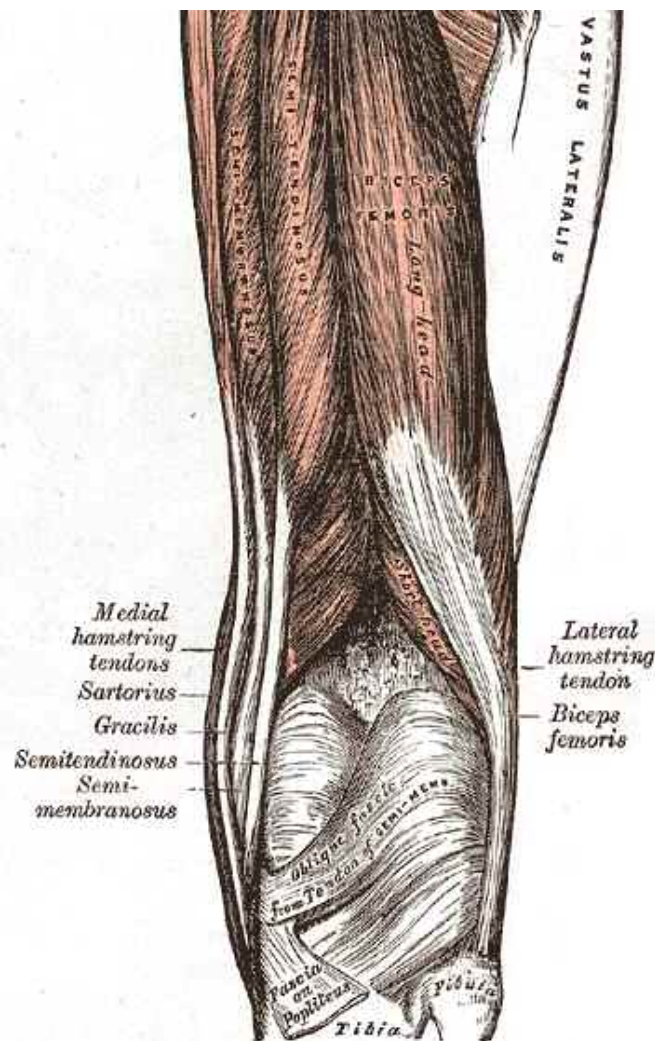

Figure 3.3. Muscles and tendons of the knee (Gray H, 1918)

In their 1998 report EEVC WG17 (who followed on from WG10) considered PMHS test data from tests at a higher speed (40 km/h) carried out by Kajzer (European Enhanced Vehicle-safety Committee, 1998). The average peak bending moment measured in the Kajzer bending tests was 388 Nm (Kajzer *et al.*, 1997). Konosu in his ESV paper (Konosu and Tanahashi, 2003) questions the results of Kajzer and concluded that there was a mistake in the calculation method used by Kajzer to calculate the knee bending moment from the measured forces and lengths. However, there is insufficient evidence in either paper to confirm or reject this conclusion.

As living humans cannot ethically be tested at potentially injurious levels, the only method available to assess the influence of muscle tone on the stiffness and bending performance of the knee and leg bones is accident reconstruction. This method was used by Matsui (2003) when he used the EEVC WG17 legform impactor to reconstruct real pedestrian accidents. This method has the advantage that the measured outputs can be compared with the accident injuries to obtain injury risk curves for living humans. These results are discussed further in Section 3.3.1.4, however, it is interesting to note that the injury risk curve derived from these reconstructions with the WG17 impactor shows that a knee lateral bending angle of 19.2° corresponds to a 20 percent risk of injury. As this angle is at the higher end of the range found to cause knee ligament failure in PMHS tests it would be reasonable to conclude that the current maximum lateral knee bending moment of about 460 Nm (at 15°) specified for the EEVC WG17 legform impactor is appropriate or slightly too low for live humans. This conflicts with the far lower knee bending moment found in PMHS knee tests. It seems reasonable to conclude that the knee stiffness due to muscle tension is combined in a living human with the stiffness due to knee ligaments. Therefore, on the basis of the information currently available it is concluded that the EEVC WG17 knee joint stiffness is more appropriate to represent the living human than the very low stiffness selected for the Flex-PLI legform impactor.

Increasing the strength and pre-tension of the springs acting on the wire ropes that represent the collateral ligament in the mechanical knee of the Flex-PLI is thought likely to give similar results to the combined effects of muscle tension and knee ligaments, as both the muscle tendons and the collateral ligaments act in tandem in the human knee. However, to achieve the current EEVC WG17 knee stiffness in the Flex-PLI would require far larger springs than are currently used, which might be difficult or impossible to fit in the available space.

It may seem strange that there is debate and disagreement about the most appropriate biomechanical values to be used for the knee of the legform impactor; however, it is in practice very difficult to make measurements in live and PMHS subjects. It is reassuring to note that similar debates exist about most biomechanics requirements used in safety regulations; however, applying these regulations has resulted in significant improvements in vehicle safety despite these uncertainties.

Like the EEVC legform impactor, the Flex-PLI has 'bones,' sections of a simplified cylindrical shape which are much larger in diameter and heavier than the femur and tibia of a human, and the flesh in both impactors is comparatively lightweight and of uniform thickness. In a human the flesh (muscles) is heavier than the bones, is unevenly distributed and is only strongly attached at each end of the muscles. Differences like these are found in most if not all test devices used to represent humans for vehicle safety tests and are necessary for a number of reasons, the most important of which are simplification, robustness, repeatability, inclusion of instrumentation and the limitations of available materials. However, in the case of the Flex-PLI, which is intended to have greater biofidelity than the EEVC impactor, it must be questioned why bone flexibility was considered more important than mass distribution and the de-coupling of the muscle mass.

It is clear that the flexible long bones of the Flex-PLI give it greater biofidelity than the EEVC WG17 impactor; however, as discussed above, the biofidelity of the Flex-PLI knee for living humans is not proven.

3.1.1.2 Physical and mechanical properties and instrumentation

The legform specification for the EC Directive (European Parliament and Council of the European Union, 2003) as detailed in the Commission Decision (Commission of the European Communities, 2004) includes length, mass, centre of gravity and moment of inertia requirements. All these properties were derived by EEVC WG17 from those of a 50th percentile male, by making suitable adjustments to take account of the simplified shape of the impactor.

The physical measurements from (or design specification for) the prototype Flex-PLI 2003 are given by Konosu and Tanahashi (2003). A comparison of these two sets of measurements is provided in Table 3.1. Three properties have no corresponding values from the Flex-PLI as none are available in the literature.

Table 3.1. Comparison of the EEVC/EC Directive requirements and the Flex-PLI characteristics

Property	EEVC legform	Flex-PLI 2003
Total length	926 ± 5 mm	926 mm
Femur mass	8.6 ± 0.1 kg	8.4 kg
Tibia mass	4.8 ± 0.1 kg	5.6 kg
Total mass	13.4 ± 0.2 kg	14.0 kg
Femur centre of gravity (from knee centre)	217 + 10 mm	223 mm
Tibia centre of gravity (from knee centre)	233 ± 10 mm	234 mm
Femur and tibia diameter	70 ± 1 mm	
Femur moment of inertia	0.127 ± 0.01 kg.m ²	
Tibia moment of inertia	0.120 ± 0.01 kg.m ²	
Flesh thickness	25 mm	15 mm
Skin thickness	6 mm	5 mm

From Table 3.1 it can be seen that the lengths of the Flex-PLI conform to the requirements set out in the EC Directive. However, apart from having no information on the moments of inertia for the legform, the masses of the Flex-PLI are not within the design requirements. In particular, whilst the femur mass is slightly too light, the tibia mass is far greater than that of EEVC, ISO and the provisional IHRA specification and that of the 50th percentile human. Part of the increased tibia mass could be justified as an allowance for the mass of a shoe, which is not allowed for within the EEVC specification. When questioned on the lack of moment of inertia information for the Flex-PLI, Konosu replied that based on numerical simulations the moment of inertia was not thought to affect the test result (Konosu, 2004). Although this argument might be accepted for small differences in moment of inertia, the effect in this case cannot be judged due to the absence of data.

It is also important that an impactor used for regulatory testing should be robust and have accurate transducers with a suitable frequency response. The EEVC WG17 legform impactor has proved its robustness over many years and the accuracy of the transducer system has also been examined throughout the impactor development and has been shown to have acceptable accuracy and frequency response (Lawrence and Thornton, 1996; Lawrence and Rodmell, 2000). The robustness of the Flex-PLI has yet to be proven, however, its complexity is thought likely to make it less robust and possibly less repeatable. Repeatability of the Flex-PLI knee shearing mechanisms is thought likely to be poor because the stiffness is produced by a combination of several factors including the joint friction, the interlocking action of knee components and the ligament tension. In the EEVC knee the

bending and shear mechanisms are independent and repeatable. The knee ligament extension is measured in the Flex-PLI by 'string operated potentiometers', which is a relatively low accuracy and frequency response system, whereas the EEVC legform shear and bending potentiometers are directly driven by the displacements, thus providing high accuracy and frequency response.

The Flex-PLI has a maximum of 15 measurement channels that can measure the strain on the long bones, elongation of each ligament and the knee condyle compression forces on both the lateral and medial sides. The outputs of knee ligament extension are directly related to knee injury, however, on their own it is difficult to determine the combination of bending and knee shear that has caused them. The addition of condyle force measurements, which are not directly related to injury, help give an understanding of the knee joint deformation. In the WG17 legform impactor the knee transducer outputs measure separately knee shear and bending deformation, which are used to determine injury risk but also give direct information on the nature of knee loading.

As one of the vehicle measures that helps to reduce knee lateral bending is the introduction of a low load path in the bumper, early in the impact (a strong spoiler), ideally a legform impactor should be able to determine the fracture risk along the full length of the bumper contact. The multiple measurement channels on the tibia of the Flex-PLI mean that it is possible to determine the loading profile along the full length of the tibia. This is an advantage over the EEVC legform, which has only one acceleration transducer just below the knee. EEVC WG17 has recommended that the need for an additional accelerometer, at ankle level, should be a topic for consideration / research in a document supplied to the European Commission (EEVC WG17, 2002).

The measurement channels on the femur of the Flex-PLI mean that it could potentially be used to test high bumpers to determine the risk of femur fracture and in addition contribute towards the measurement of the risk of knee joint injury. This would have an advantage over the current EEVC high bumper test, which only measures the risk of femur fracture. However, to be realistic for this use the Flex-PLI would need a simplified upper body mass to be added.

JARI have stated that they hope to finish development and arrange production of the Flex-PLI by 2005. To be a valid alternative tool for possible use in phase two of the EC Directive a test tool must, amongst other things, be finalised. Ideally it should also be commercially available. However, as the performance of the final version of the Flex-PLI will need to be independently assessed before it could be adopted for phase two of the Directive, currently it must be regarded as not complying with these requirements.

3.1.2 Upper legform impactor

No alternative to the EEVC WG17 upper legform impactor test tool has been found.

As discussed in Section 3.1.1.2 the addition of an upper body mass to the Flex-PLI legform impactor might make it suitable for use in testing high bumpers. It is possible that if a hip force transducer was also fitted in the joint between the leg and the upper body mass that it might also be suitable for testing the bonnet leading edge. However, this would take both time and funding for the development programme, which means that this is not currently a viable alternative.

3.1.3 Headform

As discussed in Section 1 of this report, the EC pedestrian protection Directive has a two-stage approach. For the first phase a 3.5 kg child / small adult headform is used to test the whole bonnet surface at a speed of 35 km/h. For the second phase, the front part of the bonnet top is tested with a 2.5 kg child headform and the rear part of the bonnet top is tested with a 4.8 kg adult headform, both of which are at a test velocity of 40 km/h. This second stage uses the EEVC WG17 test methods and tools unaltered; however, before this second stage is adopted it must be subjected to the feasibility study described in this report.

Headform impactors to the EEVC WG17 specification (2.5kg and 4.8 kg) have been supplied for many years by First Technology Safety Systems (FTSS). A 3.5 kg headform impactor was not available at the time that ACEA (*Association des Constructeurs Européens d' Automobiles*) proposed the two stage approach now included in the EC Directive, so ACEA produced a specification for a 3.5 kg headform based on the ISO specification and arranged for FTSS to develop a headform to meet this specification. This was achieved by modifying the EEVC WG17 adult headform design. The ACEA 3.5 kg headforms have been available from FTSS for about a year.

As noted in Section 3 above, ISO WG2 has produced a sub-system head test method. This also uses two headform impactors, one to simulate the head of a child pedestrian and one for the head for the adult pedestrian. The ISO headform specifications differ from those of the current EEVC WG17 headforms. For the ISO child headform the group concluded that effective mass was the same as the 'static mass' (cut-off mass) of a typical 6 year old child, at 3.5 kg, and they specified a diameter of 165 mm which also matches the diameter of a typical 6 year old child's head measured about the forehead (this is about the same diameter as the average adult head, but the child face is shorter). However, the EEVC WG17 had concluded that the 'effective mass' of the child headform should be 1 kg less than the static mass of a typical six-year-old child, i.e. 2.5 kg. The 'effective mass' is the estimated head mass seen by the car bonnet when striking a whole pedestrian and includes an allowance for the force acting through the neck during the head impact. To achieve this lower mass the 130 mm diameter of the EEVC headform is smaller than that of the six-year-old child it represents. For the ISO adult headform the diameter is the same as that of the EEVC adult headform at 165 mm, which matches a typical adult head diameter, but the mass is slightly lower than that specified by the EEVC. Again, ISO concluded that the adult 'effective mass' was the same as the 'static mass' of the average adult and selected 4.5 kg. However, the EEVC had concluded that the 'effective mass' should be more than the static mass of the average adult and selected a mass of 4.8 kg, which includes an 'effective mass' allowance of 0.3 kg.

Effective head mass can be found using two principle methods, by reconstruction of real or PMHS impacts or by the use of a real or mathematical pedestrian dummy. The EEVC pedestrian working group determined 'effective mass' using mathematical simulations for both the child and adult and, in addition for the adult, they reconstructed PMHS tests. ISO used just mathematical simulations for both headforms to determine 'effective mass'. Any method that uses dummies to determine 'effective mass' is reliant on the biofidelity of the dummy, in particular the neck, shoulders and chest. Unfortunately, these features were unlikely to be sufficiently accurate in the models available to EEVC and ISO. It is questionable whether any current model is of sufficient biofidelity to resolve this issue, however, examination of pedestrian kinematics tends to support a lower effective mass for the head of small children and a higher mass for adults. It could be argued that EEVC WG10, by reconstructing PMHS head impacts with a 4.8 kg headform and obtaining reasonable agreement in head acceleration and HIC values, showed that the EEVC adult headform is more realistic; however, it is unlikely that the results would be particularly sensitive to small changes in mass. Therefore it is difficult to make a case for choosing between the available headform masses on the basis of effective mass alone. As discussed in Section 7, recommendations for the adult headform mass are possible when the test methods and feasibility issues are considered together.

The ISO headform specifications were used as the basis of the draft International Harmonised Research Activities – Pedestrian Safety – Working Group (IHRA-PS-WG) head test method and the IHRA specification for the 3.5 kg child and 4.5 kg adult headforms is essentially the same as that of ISO.

The Japan Ministry of Land, Infrastructure and Transport (MLIT) with the help of IHRA, the Japan Automobile Manufacturers Association, Inc. (JAMA) and the Japan Automobile Research Institute (JARI, who are also members of the ISO and IHRA working groups) have developed a pedestrian head protection requirement. The Japanese requirement is based on the ISO / IHRA headform specifications but no examples of 3.5 kg child and 4.5 kg adult headforms complying with the ISO / IHRA specification existed. Therefore the Japan Automobile Manufacturers' Association, Inc. (JAMA) in conjunction with the Japan Automobile Research Institute (JARI) developed prototypes of new child and adult headform impactors, designed specifically to meet both the requirements of the

ISO specification and the specification proposed, and later included, in the Japan MLIT requirement (Matsui *et al.*, 2003). These impactors are referred to as the JAMA-JARI child and adult headform impactors. These new headforms meet the ISO and Japan MLIT specification and can be used in performance assessment tests conducted by the Japan MLIT and J-NCAP. The specification of the JAMA-JARI child headform is such that it also meets the requirements of the first stage of the EC Directive with the exception that different certification methods are used. Certification tests are used to test the complete impactor system and show that its performance is as intended. In the case of the JAMA-JARI child headform, although the certification method is very different from that in the first stage of the EC Directive it is thought that the impactor is likely to meet or come close to meeting the EC certification limits; any differences could probably be resolved by using a head skin with a slightly different formulation of raw materials. Therefore, if found necessary, there would be no problem in adopting this headform for use in the EC Directive. With the exception of the headform mass and related properties the adult JAMA-JARI headform specification is very similar to that of the adult in the EC Directive. However, the adult JAMA-JARI headform has a different certification method to the EC Directive. Therefore, if found necessary to adopt this headform for use in the EC Directive minor changes would have to be made in the specification and either certification limits would have to be found and set for a 4.5 kg headform using the EC certification method or the JAMA-JARI certification method would have to be inserted into the EC Directive.

Like the EEVC WG17 and ACEA headforms the JAMA-JARI child and adult headform impactors consist of an aluminium hemispherical core with an outer synthetic rubber 'skin'. The headform skin represents the flesh covering of a pedestrian's head. The JAMA-JARI child and adult headform cores are available from S•Tech Co. Ltd., Japan (<http://www.s-techinc.co.jp>) and the skins are available from Jasti Co. Ltd., Japan (<http://www.jasti.co.jp>).

A 4.5 kg headform is also available from First Technology Safety Systems (FTSS) that meets the ISO and Japan MLIT specifications.

As mentioned in Section 3.1.1.2, to be a valid alternative tool for possible use in the second phase of the EC Directive a test tool must, amongst other things, be finalised. Ideally it should also be commercially available. It can be seen that the three alternative headforms (JAMA-JARI and ACEA) described above comply with these requirements.

3.1.4 Pedestrian dummy

Pedestrian dummies might appear to be a more obvious choice for a regulatory test and they do have a number of benefits, which include a simple test method, and impact conditions for each main contact with the car that automatically adapt to vehicle shape and stiffness. However, they also have significant disadvantages:

- The repeatability of tests using pedestrian dummies is relatively poor, small variations in the initial dummy set-up will have an increasing influence on the impact severity and position on the car of dummy body parts, as the impact progresses.
- If pedestrian dummies were used then a range of pedestrian dummies of different stature would be required to test all areas likely to be hit in real life. This is because the impact locations for key body parts such as the head are very dependent on the stature of the pedestrian, as well as the position of first contact across the width of the vehicle and the motion of the pedestrian before contact. It would also be very difficult to predict and control the impact locations of dummy body parts to test selected danger points accurately, particularly for the head.
- To give appropriate results the biofidelity of the whole pedestrian dummy must be correct.

For test methods intended for legislative use, as in this case, sub-system test methods overcome these disadvantages. Sub-system tests have the following advantages over full-scale dummy tests:

- They can easily be used to test the whole area likely to strike pedestrians.

- They can be aimed accurately at selected danger points.
- They give good repeatability.
- The tests cost less to perform.
- The test requirements are simpler for the car manufacturers to design to and to model mathematically.
- They can be more easily used in component development.
- The test severity can be adjusted (e.g. by energy cap) to take account of practical design limitations.
- They can include corrections in the test conditions for the limitations in the biofidelity of the pedestrian dummies used to develop them.

Therefore, the mandate for EEVC WG10 was to develop sub-system test methods and, as already noted, these test methods were subsequently reviewed and updated by EEVC WG17.

Whilst it may not be practical to use dummies in regulatory tests they are very valuable for research purposes, to help understand the kinematics and injury mechanisms and to review the overall effects of pedestrian protection measures. A pedestrian dummy called Polar has been developed recently in a joint collaboration between GESAC Inc., Honda R&D and JARI (Mizuno, 2003). The latest version of the dummy, known as Polar II, includes a human-like representation of the knee, a flexible tibia and more compliance of the shoulder than the Polar I. Currently the Polar II dummy is a prototype and it is not commercially available. Although it appears to provide good biofidelity when compared with the PMHS data selected, it is not clear from the reported results if all biofidelity issues have been fully addressed. For example, the lateral knee stiffness is far lower than that selected by EEVC WG17 with no allowance for muscle tension. The dummy's instrumentation is also thought to be insufficient to make it suitable for regulatory use.

Therefore, although it is clearly an improvement in biofidelity over older pedestrian dummies it is not considered sufficiently well developed to be used in a regulatory test; nor does it overcome the other difficulties for using dummies, listed above.

In the future, once the pedestrian dummies are sufficiently well developed and instrumented, it might be possible to use a combination of dummy tests and component tests to overcome the need for a family of dummies of different sizes. This would be facilitated by limiting testing in each area to those statures most vulnerable to injury. This principle is used in the EEVC test methods where the bumper and bonnet leading edge is only tested with adult impactors because accident data suggests that their longer limbs are more vulnerable to injury from these parts than children in accidents up to 40 km/h.

3.2 Alternative test methods

Both the Japanese MLIT and Euro NCAP methods have a tolerance not only on impact speed but also on the accuracy with which it is measured. The Japanese MLIT require "The instrument for measuring speed shall have a precision of $\pm 1\%$ and a resolution of not more than 0.5 km/h". Euro NCAP require "The velocity measuring device should be able to measure to an accuracy of at least ± 0.02 m/s". Neither phase one or phase two of the EC Directive has a tolerance for this and it is recommended that the Euro NCAP tolerance of ± 0.02 m/s be included in phase two of the EC Directive.

3.2.1 Legform test method

Only ISO have a complete alternative legform test method; as already noted the ISO legform test method is very similar to the EEVC one and in many respects it has been based on it. Although the ISO legform test method is not identical to the EEVC method there are no significant differences.

Therefore there would be no benefit in using the ISO test method in phase two of the EC Directive. Also, as it is less specific, written in a different style and comparatively untested, it offers no improvement over the current legform test method for phase two of the EC Directive.

IHRA are also currently developing a legform test procedure, however, as they started this task only recently, it is far from complete and therefore not currently suitable for consideration as an alternative test method for the second phase of the EC Directive. In reviewing the EEVC and ISO test methods one interesting point was raised in the IHRA discussions, relating to the lack of a shoe thickness allowance in both the EEVC and ISO test methods. Both the EEVC and ISO test methods require the 'foot' end of the impactor to be at ground level at impact with the car. The anthropometric data used to specify the length of the legform impactor is for people without shoes and, as most pedestrians are assumed to be wearing them, then the normal allowance of 25 mm should be added for their thickness. Therefore, the IHRA working group agreed to require the foot end of the impactor to be 25 mm above ground level in their test method.

3.2.2 Upper legform test method

Currently there is no alternative to the EEVC WG17 upper legform test method for the bonnet leading edge test. As discussed in Section 3.1.2 the addition of an upper body mass and a hip force transducer to the Flex-PLI legform impactor might make it suitable for testing the bonnet leading edge. If such a tool were available then the test method might simply consist of firing it horizontally into the front of the vehicle at a fixed velocity and mass. However, as this would take both time and funding for the development programme, this is not currently a viable alternative test method.

3.2.3 Headform test method

As discussed in Section 3, there are effectively three alternative headform test methods, the ISO, IHRA and Japanese MLIT methods, all three of which use 3.5 kg child and 4.5 kg adult headforms.

3.2.3.1 Test area

The ISO pedestrian safety working group (ISO TC22/SC10/WG2) believes that the information necessary to specify a narrow boundary separating the acceptable impact zones for the child or adult head impactor is not currently available. The working group has concluded that only the child head impactor should be used at wrap around distances (WAD's) of 1500 mm or less, only the adult head impactor should be used at WAD's of 2100 mm or more and that a transition zone exists within the WAD range of 1500 - 2100 mm. This transition zone is believed, by the working group, to be narrower than 600 mm in real world impacts but that there is insufficient information currently available to specify the location of the transition zone within the 1500-2100 mm WAD range. They specify that either a child or adult impactor (but not both) should be used in tests within this transition zone. Therefore the latest draft procedure for the child headform tests specifies an impact zone from 1000 mm to 2100 mm WAD (International Organization for Standardization, 2003a) and for the adult headform test from 1500 mm to 2100 mm WAD (International Organization for Standardization, 2003b). The further ISO working group resolution is located in the draft child test procedure (International Organization for Standardization, 2003a) and recommends that until further data are obtained or additional analyses are performed, each organisation specifying head impactor tests should use current data to determine the size and location of a transition zone within the WAD range of 1500-2100 mm.

IHRA have proposed two options for specifying the child and adult areas; the first has an overlapping child and adult zone. This option has the advantage of reproducing the accident situation where there is an area likely to be struck by both light and heavy heads. The second IHRA option is to have a sudden transition between the adult and child zones; this second method is also used by EEVC. It is used because in practice a step change in stiffness within the same vehicle structure is not feasible. Therefore to pass each side of the line with the different headform masses will result in complying

vehicle designs having a 'safe' overlapping zone about the line. The IHRA working group have gathered data from in-depth accident studies. Analysis of the data with measured head impact locations showed that the transition from child to adult starts at the Wrap Around Distance (WAD) of 1400 mm and ends at 1700 mm. Although these data have not been published it is the reason why IHRA had selected this as an overlapping child and adult zone in their test methods (Mizuno, 2003). Therefore it can be seen that the wrap around distances in the EEVC method is almost in the middle of the IHRA child to adult transition zone, whereas the ISO overlap appears less appropriate, extending from 1500 to 2100 mm WAD. It can therefore be concluded that the EEVC step change transition from child to adult is appropriate for most vehicles. The only situation where this method will not provide a safe zone for both child and adult is when the transition line coincides with a change in the vehicle structure, such as the joint between the rear of the bonnet and the heater air intake / windscreen base.

Since last reporting the proposed IHRA head test procedures (Mizuno, 2003) the IHRA working group have decided to change the start point of the child head test zone from 900 mm to 1000 mm to align with other test methods. Therefore the current IHRA zones are, for the child zone, starting at a wrap around distance of 1000 mm and ending at 1700 mm and for the adult zone, starting at 1400 mm and ending at 2400 mm (or up to the top windscreen frame for shorter vehicles), but as noted above they also give the option of a sudden transition between child and adult. Unlike the EEVC method the IHRA adult test area extends beyond the base of the windscreen up to 2400 mm, this reflects the ambition of the IHRA-PS-WG to include the vehicle A-pillars, the complete windscreen and the leading edge of the roof in the test zone. However, although these areas are the cause of serious and fatal injuries in a large proportion of accidents, they were deliberately excluded from the mandate of EEVC WG10 and WG17 on the grounds of feasibility. As these feasibility issues are still pertinent it is not considered reasonable to extend the test area in phase two of the Directive to include these parts. However, the IHRA test methods for these areas will be of use in developing new solutions, such as A-pillar airbags, which might eventually overcome the feasibility issues.

3.2.3.2 Head mass

The discussion on effective mass in Section 3.1.3 supports the masses selected by EEVC of 2.5 kg and 4.8 kg respectively to represent a six-year-old child and an adult pedestrian. However, if the EEVC decision on headform mass is considered in conjunction with their test method, where the whole 'child area' is tested with an impactor representing the effective mass of a six-year-old child, then the appropriateness of the 2.5 kg mass is less clear. This is because the child test area, which lies between the 1000 mm and 1500mm wrap around lines and the bonnet side reference lines, would in real life be struck by the heads of pedestrians of a range of ages and statures, from approximately four years old up to about twelve years old but including some small adults. The static head mass of small adult females (5th percentile) is approximately the same as children of about twelve years old and Robbins estimates the 5th percentile female head mass to be 3.7 kg (Robbins, 1985). The difference between static and effective mass for this group is thought to be small, so 3.7 kg is thought to be appropriate value for the effective head mass for those pedestrians of statures likely to hit towards the rear of the child zone. Therefore the effective head mass is thought to start from about 2.5 kg at the front and increase to about 3.7 kg at the rear of the child zone and the 2.5 kg headform is more appropriate for the front of the child zone. Consequently, overall it might have been better if EEVC had chosen a heavier mass to represent the range of ages and statures striking the whole child area. In the 15th meeting of the EEVC WG17 the use of a 3.5 kg headform instead of the 2.5 kg headform was discussed. Based on similar arguments to those described above, EEVC WG17 concluded that they had no objections to adopting a 3.5 kg mass for testing the child area.

As noted earlier, the slightly heavier EEVC adult mass is supported by kinematics (body mass acting through neck) and PMHS reconstructions, however, the possible use of the alternative 4.5 kg mass is discussed in Section 7 under feasibility issues.

3.2.3.3 Impact velocity

The child (International Organization for Standardization, 2003a, Annex C) and adult (International Organization for Standardization, 2003b, Annex B) ISO headform test procedures contain information on the relationship between the vehicle velocity and the head impact velocity. The head impact velocity is described as being related to the vehicle velocity by the relationship shown in Equation 3.1.

$$v_{HF} = kv \quad \text{Equation 3.1}$$

where:

v_{HF} = the head impact velocity

k = a constant

v = the vehicle velocity

From MADYMO modelling and cadaver data (three sources), the value of 'k' for a child is quoted as being between 0.72 and 0.78.

From Annex B in the ISO adult headform test document, it is stated that k has been determined as being between 0.7 and 1.4 but to facilitate uniformity, a value of one was recommended.

The IHRA working group are also using mathematical simulation results to determine child and adult head impact conditions, with the aim of providing a more complex head velocity / vehicle shape / stature or wrap around distance on the car. The provisional IHRA head test velocities are from three different simulation models all simulating the same range of vehicle shapes and impact velocities. These different models produced a wide variation in results even when the same vehicle speed and shape were compared. In order to provide provisional values for the three main vehicle shape categories of sedan plus, SUV and one box, the simulation results were combined and the average and the \pm one standard deviation values were calculated. The IHRA provisional head impact test conditions can be seen below, in Tables 3.2 and 3.3, for a vehicle impact speed of 40 km/h.

However, the IHRA work is not yet completed and the current impact conditions are provisional. The wide variation in the results can be seen in the large \pm one standard deviation values. It is thought that much of this variation was due to the differences between the models used by IHRA, which utilise simplified car and pedestrian models. One of the important deficiencies in the three models used was the simplified stiff shoulder, which, if it makes contact before the head, could erroneously reduce the recorded head impact velocity. Following the study used to generate the above IHRA provisional impact conditions, the IHRA working group selected one of the three models used, the JARI model, as a basis for further developments. Once the model is sufficiently well developed the IHRA aim is to simulate the same matrix of vehicle shapes in order to refine the impact conditions for their headform test method. Neale compared the performance of the IHRA (JARI) model with two other pedestrian models, one a TNO model and the other a modified version of the JARI model which included a revised shoulder (Neale *et al.*, 2003). He compared the performance of the three simulation models when the shoulder was impacted in a similar test to that performed to the shoulders of PMHS subjects and concluded that they all had very poor shoulder biofidelity. Comparing the original JARI pedestrian model with the TNO pedestrian model in simulated vehicle-pedestrian impacts into the same vehicle front, Neale found differences in predicted head impact velocity as high as 14 km/h. Therefore, TRL have concluded that it would be premature to use the current provisional IHRA head impact conditions to judge the suitability of the head impact conditions in the second phase of the EC Directive.

Table 3.2. IHRA Child head impact conditions – average and ± 1 standard deviation – 40 km/h car impact speed

Shape corridor	Impact velocity (km/h)			Impact angle (°)		
	Bonnet	Windshield	BLE/Grille	Bonnet	Windshield	BLE/Grille
Sedan +	30.0 \pm 4.0	nc	nc	66.0 \pm 6.3	nc	nc
SUV	27.2 \pm 1.6	nc	32.0 \pm 3.6	59.2 \pm 2.6	nc	22.5 \pm 4.2
One box	27.6 \pm 0.8	nc	33.2 \pm 3.2	49.8 \pm 1.8	nc	17.4 \pm 6.1

Table 3.3. IHRA Adult head impact conditions – average and ± 1 standard deviation – 40 km/h car impact speed

Shape corridor	Impact velocity (km/h)			Impact angle (°)		
	Bonnet	Windshield	BLE/Grille	Bonnet	Windshield	BLE/Grille
Sedan +	30.4 \pm 7.2	35.2 \pm 6.8	nc	66.0 \pm 14.0	38.4 \pm 10.9	nc
SUV	30.8 \pm 8.8	nc	nc	76.7 \pm 22.2	nc	nc
One box	nc	29.6 \pm 3.2	nc	nc	47.3 \pm 9.6	nc

EEVC WG10 considered many sources of the head impact velocity data including results of PMHS tests, accident reconstructions using pedestrian dummies and mathematical simulations for the adult and child (Glaeser, 1991), before selecting a speed of 40 km/h. When reviewing the head test methods WG17 considered more recent mathematical simulation results of impacts between 5th percentile adult female, and 50th and 95th percentile adult male pedestrian dummies against three vehicle shapes, small, medium and off-road (Green and Young, 1998). These results showed that at a vehicle impact velocity of 40 km/h the head impact velocity of the 5th percentile was 32 km/h for the small vehicle and 39 km/h for the medium vehicle (k values of 0.79 to 0.97). For the 50th percentile with a vehicle velocity of 40 km/h the head velocity was 55 km/h for the same two vehicle shapes and for the 95th percentile it was about 60 km/h (k value of about 1.5). WG17 concluded that it was not feasible to have a test method for the child where the velocity varied depending on the shape of the vehicle and stature or wrap around distance on the car. They concluded that the head impact velocity of a child is likely to be very sensitive to the relationship between the height of the bonnet leading edge (BLE) and the height of the head. When the heights are similar then the head impact velocity is likely to be close to that of the car, when the BLE is level with the shoulder or high on the chest, head velocities are likely to be low and for taller children the velocity will again be higher. Therefore they confirmed the decision made by WG10 to use a velocity of 40 km/h for the child, giving a k value of 1.0. As the net effect of this decision is to require appropriate protection for the most vulnerable child statures and protection at slightly higher speeds for the less vulnerable statures, this appears to be a reasonable decision.

EEVC WG17 also reviewed adult head impact velocity data, which indicated that the velocity could be as high as 1.45 times the car impact velocity (European Enhanced Vehicle-safety Committee, 1998). However, they confirmed the WG10 decision to use a compromise value of 40 km/h. The following considerations were the main reasons for reaching this decision:

- The bonnet lengths (up to and including the base of the windscreen) of most European cars are too short to be hit by the heads of taller pedestrians. As the ratio of head velocity to car impact velocity (k) is closer to 1 for shorter adult pedestrians then a velocity of 40 km/h is appropriate.
- Depending on the bonnet length and pedestrian stature, higher impacts velocities (k values of more than 1) are likely at the rear of the bonnet / base of the windscreen. However, the crush depth needed to protect increases with the square of the velocity. The theoretical crush depth needed to achieve a HIC 1000 value in a normal impact at 40 km/h can be calculated to be about 68 mm but this increases to 167 mm at 56 km/h (1.4 x 40 km/h). It was concluded that although a k value of 1.4 would be appropriate for those few cars with longer bonnets it would not be feasible to provide the necessary crush depth in this area.
- The central unsupported area of the windscreen is normally safe for the head of a pedestrian in impacts up to 40 km/h, so this does not need testing.
- Testing the A-pillars and windscreen upper frame had been deliberately excluded from their mandate due to feasibility issues.

More recently, the possibility of using airbags to protect the A-pillar has been considered (Maki *et al.*, 2003), and these solutions could also be extended to the upper windscreen frame. To avoid unacceptable inappropriate activation, these methods need a reliable pre-impact pedestrian sensing and triggering system, which is currently thought to need many years of development before it may be available for use. Therefore, it is not appropriate to have at this time a regulatory test for this area (see comments on test methods for this area in Section 3.2.3.1).

It can be seen that there is a wide variation in head velocities found in studies. There are a number of reasons for the wide range of the final head impact velocities; these include pre-impact positions, stature, vehicle shape and, perhaps most importantly, the more random effects of earlier contacts of arm, shoulder, chest, etc. In dummy and mathematical simulation tests, unrealistically low head velocities are likely to be seen when arm (hand and elbow) and shoulder contacts occur, as these parts are normally far stiffer in dummies than in humans (for the shoulder see Neale *et al.*, 2003).

It might be thought reasonable to use the mean values for the test velocity and this approach has been used in the Japanese head test method. However, an average head velocity is, at best, likely to provide effective protection in only the 50 percent of accidents that occur at the selected vehicle speed, and will be insufficient for the remaining higher head speed accidents. In the case of the selected IHRA head velocity data that were used to determine the Japanese test velocity, there were a few very low values that skewed (reduced) the average head velocity to 32 km/h for a vehicle velocity of 40 km/h. As a result the velocity of 32 km/h selected for the Japanese test represents less than 50 percent of accidents. The aim of the Directive is to provide effective protection that will produce significant savings in casualties in accidents at 40 km/h. This would not be achieved by using an average velocity of 32 km/h. As can be seen from the paragraphs above the velocity selected by EEC for the adult head test of 40 km/h already includes a reduction for feasibility, for areas towards the rear of the bonnet where the head velocity may exceed the vehicle impact velocity. Therefore no change in the adult head test velocity for the second phase of the EC Directive is justified on the basis of improving the test method.

3.2.3.4 Head impact angle

The ISO child and adult head test procedures specify an angle of 53 degrees for the child and 65 degrees for the adult with respect to the horizontal. However, the simulation data on which the ISO angles are based show a wide variation for impact speed and other variables. These values are given in the form of a series of points in a graph in the ISO procedures. By scaling from these graphs it has been found that the ISO simulations for the child at 40 km/h vary between 68 to 42 degrees and for the adult between 62 and 58 degrees. The provisional IHRA head impact angles are also given in Tables 3.2 and 3.3. For the comparison with the Directive phase two requirements, the bonnet of the

sedan+ shape category is thought to be most appropriate and this gives 66 degrees (59.7° to 72.3°) for the child and 66 degrees (52° to 80°) for the adult, with the range given in brackets being the plus and minus one standard deviation values. However, as already noted, the IHRA work is not yet completed and the current impact conditions are provisional and are based on simulation models that have amongst other limitations, poor shoulder biofidelity (Neale *et al.*, 2003). The MLIT draft head test procedure is based on a subset of the IHRA data. The angles used vary by car type but for the sedan are 65 degrees for both the child and adult headform impactors.

The EEVC headform test angles, used in phase two of the EC Directive, of 50 degrees for the child and 65 degrees for the adult can be compared with the above angles. It can be seen that the child headform angle lies inside the ISO range for 40 km/h but outside the IHRA ± 1 standard deviation range. The EEVC adult headform angle is the same as the ISO angle yet lies outside of the ISO range for 40 km/h and is only one degree away from the provisional IHRA value. These EEVC values were selected from a combination of full-scale car to PMHS tests and computer simulations. The PMHS tests considered by WG10 (Glaeser, 1991), were all for adults and included initial standing positions of facing sideways, backwards and forwards. These results peaked at 60 degrees and the bulk of them fell within a range of 50 to 80 degrees. The results from the simulations considered by WG10 gave fairly consistent results for the 50th percentile adult for all car shapes considered, with an average of about 67 degrees (77° relative to the bonnet surface) (Janssen and Nieboer, 1990). So it can be seen, for the adult, that WG10 selected a nominal angle between the results found by simulation and PMHS tests when selecting 65 degrees. For the child, WG10 considered simulation results for a 5th percent adult female and a 6-year-old child (Janssen and Nieboer, 1990). A 5th percentile adult female is often taken to be equivalent to a 50th percentile 12-year-old child. The simulation results for the 5th percentile female gave similar average values to those found for the 50th percentile adult male. The simulation results for the 6-year-old child showed that the head impact angle was more sensitive to car shape, particularly to the height of the bonnet leading edge; however, an average value of 45 degrees (55° relative to the bonnet) was found. So it can be seen that WG10 used a combination of 6-year-old child and 5th percentile female simulation results to select the child head impact angle of 50 degrees, with a bias towards the 6-year-old child.

The range of results in the ISO, IHRA and EEVC impact angle data described above is most probably representative of real life due to differences in stature, initial standing position (stance), vehicle shape and vehicle to pedestrian interactions. However, the difference in absolute values from the simulations may be due to differences / deficiencies in the biofidelity of the models.

Because of the wide range of results in the above impact angle data it is necessary to consider the sensitivity of the head protection level achieved to this parameter, in order to decide if a fixed or variable test angle is needed in the test method. It can be concluded that the highest level of protection would be required when the impact is normal to the bonnet surface when all the headform's velocity has to be absorbed by the structure, and less protection would be required in more oblique impacts. Therefore, if it is assumed that a wide variation in head angle occurs randomly in real life, then the proportion of the accident population protected would increase as the test angle approached normal to the bonnet surface. Given sufficient data on head impact angle it should be possible to select fixed angles for the child and adult test methods that would be effective in requiring protection for a selected proportion of accidents. The angle of the surface of car bonnets is not fixed and is a function of size, type and styling, however, from a small survey it is thought that 15 degrees is a typical angle for conventionally shaped car type vehicles. Therefore, if one fixed angle is selected, assuming that 15 degrees is a typical bonnet angle, then all of the population would be protected if 75 degrees was used for both tests. Indeed as this angle is higher than the current data suggests, then the net effect would probably result in an average protection level effective at speeds somewhat in excess of 40 km/h covering a slightly larger target group than intended. However, given the provisional nature of the IHRA angle data and the difficulties in providing head protection, it would appear unreasonable to increase the test severity by making the impact more normal than the test requirement currently in the second phase of the EC Directive.

3.2.4 Hybrid-test

Kuehn *et al.* (2003) discuss the relative merits and flaws with different methods of testing the protection for pedestrians afforded by cars. They state that at present, due to the lack of proper test devices, full-scale tests are not able to reproduce the pedestrian kinematics in real accidents and the reproducibility of pedestrian-car crashes is not guaranteed, and they mention the Polar II dummy as a potential test tool for the future. The discussion of component tests introduces the concept that the test may not always be representative of a pedestrian accident event and requires knowledge about accident events to interpret the results in the right way. This leads Kuehn *et al.* to the concept of a hybrid-test procedure, linking accident analysis, numerical simulation and component testing.

The proposed Hybrid-test would use numerical simulation to modify the EEVC test procedures for each car tested. Vehicle specific test parameters, such as head impact velocity and impact angle for the adult and child headforms would be deduced from simulations.

This advanced procedure requires improved pedestrian models; Kuehn *et al.* mention the shoulder of the models as being too stiff and the scaled child model also needing improvement in particular.

A second option is to use a combination of pedestrian dummy and subsystem tests. For example two dummy statures could be used to test the vehicle front end (bumper, grill and bonnet leading edge) and child and adult headform sub-system tests used to test the bonnet top area. If the two dummy sizes selected match the child and adult statures most at risk of injury from the front end, then protection for in-between statures could be assumed. The need for a large family of dummy statures to test the head protection for the whole bonnet top could be avoided by a separate head sub-system test using child and adult headforms.

However, although both of the above hybrid testing ideas are interesting approaches, they clearly need further development before they are suitable for use. Therefore, they cannot be considered as viable alternative methods for use in phase two of the EC Directive.

3.3 Proposed refinements to the EEVC test methods and criteria

Alternative test methods and the data which were used in their development are one potential source which can be used to refine the EEVC test methods used in the second phase of the EC Directive, and this has already been discussed in Sections 3.1 and 3.2. The conclusions from this are included below. A second source is research proposals criticising or suggesting improvements to the EEVC test tools, methods and criteria and these are also discussed below.

One effect of requiring pedestrian protection by legislation is that in practice car manufacturers have to achieve a higher level of protection than the minimum requirements to ensure the vehicles obtain regulatory approval. Following approval, when the vehicle is in mass production, they are required to ensure that the 'worst' combination of manufacturing and test variations would not result in a vehicle that would not achieve the performance requirements. The net effect of this is that manufacturers typically aim to be inside the protection requirements by about 20 or 25 percent and in addition they will have to allow some extra crush depth in case the vehicle is slightly softer than intended. These manufacturer's additional tolerances are likely to mean that typically most vehicles will protect a greater portion of the population at the intended impact speed and be safe for most pedestrians at slightly higher speeds than the intended impact speed. Obviously this is not normally a problem, as it results in additional savings, however, if it is very difficult to provide the minimum protection required, then having to provide these extra margins might make a regulation less feasible. Feasibility issues are discussed later in this report in Section 7.

As noted in Section 3.2, other test procedures have a tolerance for the minimum accuracy of the equipment used to measure the velocity of all the pedestrian sub-system impactors. The use of inaccurate speed measuring equipment would have adverse implications for feasibility because, to ensure approval, manufacturers would have to assume that a vehicle could be subjected to approval tests at a higher velocity than that specified. Therefore it is recommended that for all test procedures, in phase two of the EC Directive, a tolerance should be introduced on the accuracy with which impact

speed is measured. Consideration should be given to introducing the Euro NCAP tolerance of ± 0.02 m/s.

3.3.1 Legform test

3.3.1.1 Legform tool

Although, as concluded in Section 3.1.1, the Flex-PLI is unlikely to be finalised and fully assessed until after the requirements of phase two of the EC Directive are finalised, some aspects of the design might be applied to the EEVC legform. Adoption of a flexible tibia would improve the EEVC impactor; however, it is not clear if the added complexity would be worth any improvement in biofidelity. Much of the differences between the Flex-PLI and the EEVC impactor are attributed to the flexible bones of the Flex-PLI, but these are thought by TRL to be mainly due to the higher lateral bending moment of the EEVC knee. It would also be possible to modify the lateral bending moment of the EEVC knee to match the bending moment of PMHS knees although it is thought that the EEVC bending moment is more appropriate for live humans with muscle tension. Therefore, no changes to the EEVC test tool are recommended for phase two of the EC Directive.

Analysis of the use of tibia acceleration as an index of lower leg fracture was carried out by Konosu *et al.* (2001). They stated that the relationship between tibia acceleration in legform tests and fracture was obtained from a PMHS test series in which the impact condition was a normal bumper height and the acceleration was measured at the upper part of the tibia. However, when the impact point was changed, tibia fracture could occur even with small tibia accelerations measured at the current EEVC position (just below the knee). Konosu *et al.* went on to suggest that when the tibia acceleration is used for the leg injury criterion, the measurement point of tibia acceleration should be changed to a proper position for each test.

As already noted in Section 3.1.1.2, EEVC WG17 has recommended that the need for a second accelerometer at ankle level should be a topic for consideration / research. The use of two accelerometers rather than a movable one will be more practical and will avoid the need to know the 'proper position for each test' (the position of the underlying hardest area of each bumper under test). Although it would be comparatively simple to amend the EEVC legform impactor design to include a second accelerometer the test method would need to include suitable pass / fail limits for each or a method of combining the two outputs.

It might be beneficial to have two tibia accelerometers; this is not recommended for phase two of the EC Directive, as more research is needed.

3.3.1.2 Legform certification

For any formal vehicle assessment, whether for regulatory or non-regulatory (e.g. consumer information) purposes, it is important to make vehicle test methods and test tools repeatable in order to achieve constant standards. In order to achieve consistent test tools, EEVC specify both the physical and dynamic requirements. Both the legform impactor and its dynamic certification method were developed in a series of stages. The final stage of development of the current dynamic certification method was to review the results of a large number of dynamic certification tests, to 35 different legform impactors that were made to the current WG17 specification. It was found that the dynamic certification acceleration and, to a lesser extent, knee shear displacement were more variable than is ideal. The legform components are manufactured to small tolerances, so these 35 impactors are likely to have very consistent physical properties of mass, centre of gravity and moment of inertia. Also, the stiffness of the bending ligaments and shear spring are controlled by their static certification procedures. Therefore, it had been assumed that most of the differences seen in the dynamic certification results for these 35 legforms was primarily due to variation in the performance of the Confor™ foam flesh during the bottoming-out phase and the sensitivity of the certification method to this. To test this assumption, dynamic certification test results with the same impactor with different

bending ligaments and flesh fitted were examined and these results support this theory (Lawrence and Hardy, 2002).

Following on from this an alternative certification test was developed with compliance built into the impact partner to more closely reproduce the loading conditions of a pedestrian-friendly bumper system. It was concluded that a representation of a repeatable deformable bumper was required to achieve this type of loading. However, it is difficult to control accurately the stiffness of many deformable materials, particularly ones that do not recover. Consequently, it was decided to explore the potential of using a steel leaf spring to represent a bumper, because the elastic modulus of steel is thought to be more consistent than the stiffness of plastically deforming materials. A steel spring will also recover completely after use, provided that the elastic limit is not exceeded, so that it can be used repeatedly. The leaf spring certification arrangement is shown in Figure 3.4.

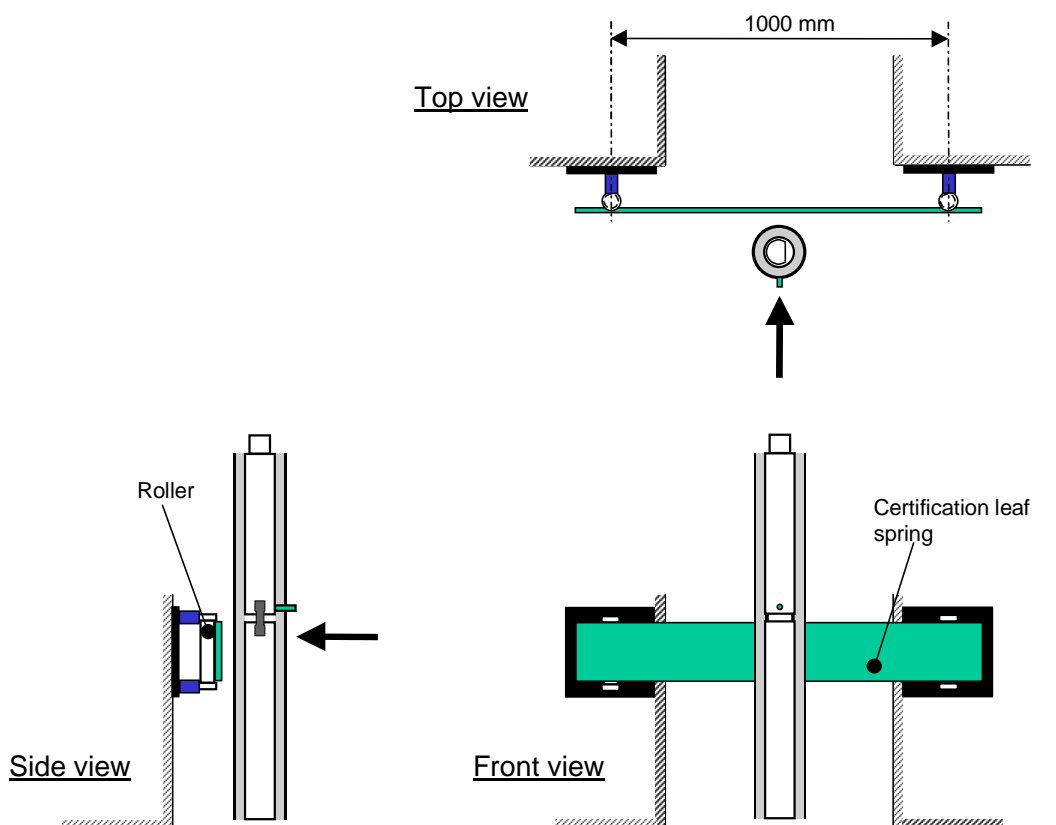

Figure 3.4. TRL alternative legform certification method

A limited number of tests were carried out using this method, but these were insufficient to show the potential of the new method or to select suitable pass / fail limits (Lawrence and Hardy, 2002). Following on from this work, TRL carried out a further programme of tests with this method (Lawrence *et al.*, 2004) and the results show that the new method appears to give smaller variation in tibia acceleration, but there are still large variations in the knee shear and the variability in knee bending angle has increased. The risk of damage through the legform striking the associated equipment on rebound is also far higher in this new test. Therefore, although the new test appears to be less sensitive to variation in the performance of the Confor™ foam during the bottoming-out phase, it does not appear to be a significant improvement over the current method.

Matsui examined the effects of a number of factors to try to find the main cause of variation in the dynamic legform certification results (Matsui and Takabyashi, 2004). Of these, only relative humidity was found to have a significant effect on the certification performance. It was hypothesised that changes in humidity were affecting the performance of the Confor™ foam material used to

represent flesh on the legform impactor. Therefore a drop weight test for the foam within a humidity controlled chamber was devised so that the effects of humidity could be examined in isolation. These results showed a clear relationship between humidity and acceleration, in both the full legform certification test and the separate drop weight tests of the foam, with the peak acceleration increasing with increasing humidity. Changes in the mass of Confor™ specimens were recorded against time whilst they were exposed to three different relative humidity atmospheres. These showed that the foam gained weight by absorbing water and that at a humidity of less than 60 percent their weight gain of about 0.5 percent had stabilised within 50 minutes of soaking. Matsui found the legform tibia acceleration to be strongly affected by humidity in the certification tests. In the drop test on the foam the drop weight accelerations increased drastically with higher humidity. He concluded that adjustment of the humidity within the test apparatus is thus one way to obtain compliance of the lower leg acceleration within the proposed EC Directive corridor.

TRL has since consulted with the Senior Materials Chemist for Confor™ foam (Mr Renninger) at the manufacturers E-A-R Speciality Composites. He confirmed that the properties of Confor™ were sensitive to humidity even though only small amounts of water are absorbed. Within the microscopic structure the water acts as a plasticizer or lubricant. Confor™ foam becomes softer as the humidity increases (while this would reduce the early acceleration in an impact test, it would make the bottoming-out phase more severe, with higher peak acceleration). It would not be possible to make Confor™ foam less sensitive to humidity without affecting its desirable properties for this application. It is less sensitive to changes in humidity in the range 25 to 60 percent relative humidity, though this would relate to general properties rather than those specific to this application.

As can be seen from Matsui's data in Figures 3.5 and 3.6, the humidity range 18 to 46 percent appears to give results within the corridor in the legform certification tests and this is supported by the drop weight test results. These results were presumably obtained with just one sheet of Confor™ foam, which may not be typical. Limited data obtained from records of TRL's impactor sales certification tests suggest that the upper limit of humidity for passing the certification test is higher, with several successful tests with relative humidity in the range 60 to 70 percent.

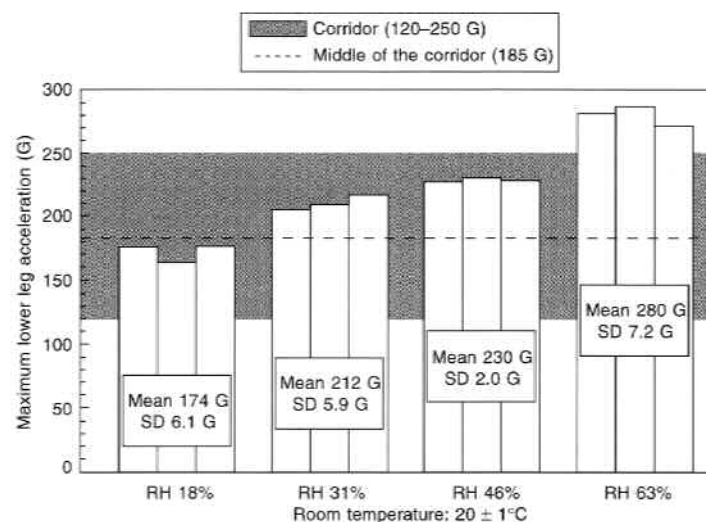

Figure 3.5. Maximum lower leg acceleration from dynamic certification tests results at different relative humidity levels (Matsui, 2004)

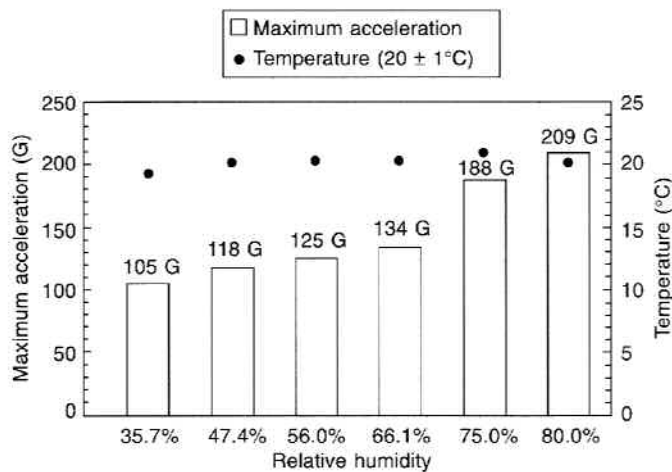

Figure 3.6. Maximum acceleration in drop tests of Confor foam specimens at various relative humidity levels (Matsui, 2004)

It appears reasonable to introduce, into the EC Directive, humidity tolerances for both legform certification tests and vehicle tests. As controlling the humidity in a test laboratory would be difficult and expensive to provide, some care needs to be used in selecting a tolerance. Depending on the width of the humidity tolerance it might be possible to test in Europe without humidity control by selecting suitable days for testing, though in some countries humidity control systems would be necessary in hot and wet seasons. However, the limited data shown in Figure 3.7 suggest that a humidity-controlled environment is likely to be necessary. For tests of vehicles with a pedestrian-friendly, compliant bumper, variations in the performance of the Confor™ flesh is not thought to be critical as any differences in the energy absorbed by the foam will be small compared with the energy that the vehicle has to absorb. However, in the current certification test, the results are likely to be more sensitive to variations in the Confor™ foam flesh. Therefore it is suggested that a tolerance of $35 \pm 15\%$ of relative humidity for vehicle tests and $35 \pm 10\%$ for certification tests be introduced in the second phase of the EC Directive. It is recommended that the effect of this tolerance on the legform dynamic certification performance should be determined by a suitable study so that the pass / fail corridors can be adjusted to take account of any reduction in variability and / or change in mean values resulting from controlling humidity.

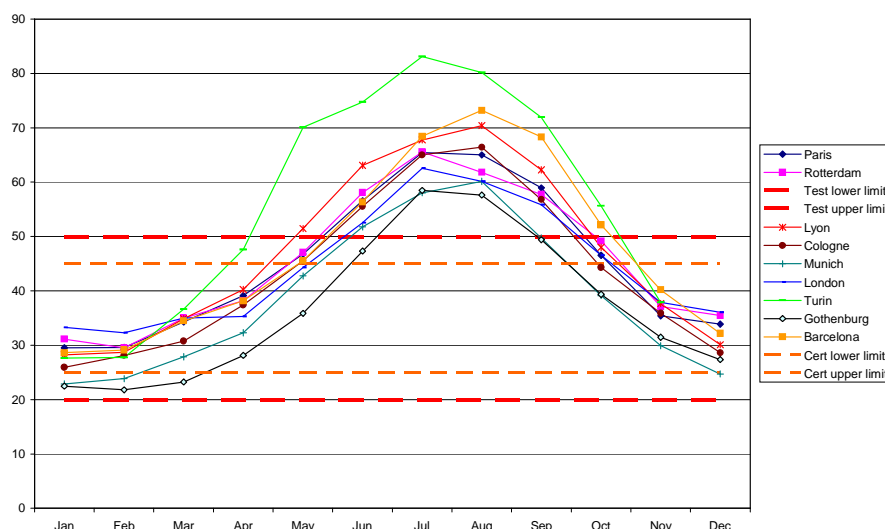

Figure 3.7. Average relative humidity for selected European cities adjusted to 20°C, assuming that the absolute humidity remains the same inside as outside

3.3.1.3 Legform test method

As already noted both the second phase of the EC Directive (EEVC WG17) and ISO test methods are essentially the same and require the 'foot' end of the impactor to be at ground level at impact with the car. However, the IHRA working group have agreed to add a 25 mm shoe allowance. This matter was recently discussed at the 15th meeting of EEVC WG17 and it is recommended that in the second phase of the EC Directive the height of the lower end of the legform impactor, at first contact with the vehicle, be 25 mm above the ground reference level.

Variations in legform test results have been found which are linked to the height and orientation of the impactor. It is suggested that both the tolerance for the height of the foot of the legform and for the legform to be vertical at the time of first impact be reduced. These two tolerances are currently ± 10 mm and ± 2 degrees in the EC Directive. To improve repeatability, ideally the tolerances of all sensitive impact parameters should be minimised, however, they must not be made so small as to be impossible to measure and achieve. Therefore, it would be preferable to conduct a study to determine the accuracy that impactor height and angle can be measured and the accuracy that it is possible to achieve in practice with a 'good' propulsion system. Nevertheless, it is possible to reach tentative conclusions on reducing these tolerances.

Impact height can be measured in a number of ways; one of the most practical methods is thought to be by measuring the height of a spot of wet paint, which has been transferred from the impactor to the bumper face during the test. This method is probably accurate to about ± 2 mm and the maximum accuracy of legform delivery is thought to be within a similar range so an overall tolerance of about ± 5 mm is considered to be achievable. Therefore it is recommended that the tolerance on impactor height be reduced to ± 5 mm in the second phase of the EC Directive.

The tolerance on angular errors in legform verticality applies to errors in any direction, but as the manufacturers suggested, the test results are likely to be most sensitive to errors in the longitudinal plane. This error can be measured in a number of ways, currently high speed video is often used to compare the legform angle with a vertical reference, this method is thought to be accurate to about ± 0.25 degrees, so this method is likely to be sufficiently accurate to use with a smaller tolerance. Other measuring methods could be devised, such as recording the difference in time between the legform breaking a light beam at its top and bottom, this combined with the velocity of the legform could be used to calculate angle more accurately. It is thought that the maximum accuracy of legform delivery is within a similar range, although the drag of instrumentation cables may introduce some additional variability in legform angle (it is probably feasible to use in-legform recording systems). Overall, a tolerance of about ± 1 degree is considered to be achievable. Therefore, it is recommended that the current angular tolerance be reduced to ± 1 degree in the second phase of the EC Directive.

As discussed above in Section 3.3.1.2, it is suggested that a tolerance of $35 \pm 15\%$ of relative humidity for vehicle tests with the legform impactor be introduced in the second phase of the EC Directive.

3.3.1.4 Legform criteria

Konosu *et al.* (2001) applied a logistic analysis method to data from PMHS tests conducted by Kajzer *et al.* (1997 and 1999). The resulting injury risk curves for bending angle and shearing displacement of the knee gave a 50 percent injury risk at 24.2 mm and 19.8°. Konosu *et al.* provided a similar logistic analysis of the results from quasi-static tests to PMHS legs conducted by Ramet *et al.*, (1995). They then went on to suggest performance criteria based on a 50 percent risk of injury. However, as knee injuries are likely to result in long-term disability, the criteria chosen for phase two of the EC Directive are set at a 20 percent injury risk. The values pertaining to a 20 percent injury risk can be read from the injury risk curves provided by Konosu *et al.* and are 18 mm of shear displacement and 14.7 degrees of knee bending angle for the Kajzer *et al.* data and 16.4 mm and 16 degrees for the Ramet *et al.* data. However, Konosu *et al.* point out that although overall bending and shear displacements measured in such experiments will be predominantly due to deflection of the knee joint, the effect of the bones bending during impact will also contribute and is used to support

the argument of Konosu *et al.* that a flexible legform impactor is needed. This conclusion resulted in the decision to develop the Flex-PLI 2003 legform impactor described in Section 3.1.1.

Further to the analysis by Konosu *et al.* (2001) on the tibia acceleration, they produced an injury risk curve for lower leg fracture. The PMHS data was taken from a test series conducted by Bunketorp *et al.* (1983). This was the same data used by EEVC to select their 20 percent injury risk value of 150 g and although a different method of analysis was used by Konosu *et al.*, this method gives an almost identical result of 152 g (scaled from the graph). Konosu *et al.* also suggest that cases where only fibula fracture occurred should be removed from the analysis. With these (two cases) removed, the 20 percent risk increases to 188 g, however, it is thought that the large change seen in the acceleration at 20 percent risk might be partially due to the statistical method used by Konosu *et al.*, which forces the curve to pass through zero. Again, Konosu *et al.* suggest a 50 percent injury risk be used as the performance criteria because tibia fractures are not normally a life threatening or disabling injury. However, the target protection level for phase two of the Directive is a 20 percent injury risk. As accident statistics show that leg injuries occur in high numbers, setting a high risk level would reduce the potential injury savings significantly. Mizuno and Ishikawa (2001) report that leg injuries are 30 percent of the AIS 2-6 injuries in the IHRA global pedestrian accident dataset.

From computer simulations using a finite element model of the human lower limb, Takahashi and Kikuchi (2001) analysed the human knee ligaments. They suggested that the legform impactor test injury criteria should be determined using a combination of bending angle and shearing displacement. The acceptance limits were found to be determined solely by the anterior cruciate ligament and the posterior cruciate ligament and therefore only these two ligaments were used in further considerations. Overlaid with the geometric performance of the ligaments were the results from dynamic simulations, which gave shearing displacements and bending moments at the time of ligament failure. From that plot, Takahashi and Kikuchi stated that the shearing displacement and the bending angle do not determine the risk of failures independently and their results were suggested as acceptance levels for knee ligament failures, although they acknowledged the need for experimental validation of their work.

The suggestion by Takahashi and Kikuchi to combine the shearing displacement and bending angle is interesting. Intuitively the concept of a biomechanical relationship between bending and shearing injury modes is believable and unremarkable. The simplest means of combining the two parameters would be to consider the peak values for each. However, these may not occur at the same time and would therefore give a false representation of the extension of the knee ligaments. Instead, bending angle would need to be plotted against shearing displacement and compared against a threshold curve.

In a presentation delivered to the IHRA pedestrian safety working group, Arnoux and Cesari (2003) reported on a finite element model of the lower limb. In the presentation, injury risk criteria for the knee ligaments are discussed for bending and shearing modes. The results indicate that for either injury mode, the injury criterion is independent of the initial velocity. The values extracted from the data are 16-20° for the bending injury mechanism and 15-18 mm of shear displacement for the shear injury mechanism.

To determine injury-related factors, data obtained in impact tests using PMHS were statistically tested by Matsui (2001). Knee lateral force, knee bending moment, knee shear displacement and knee bending angle were analysed as parameters that could correlate with the occurrence of ligament injury. Additionally, to understand the biofidelity of legform impactors with respect to the PMHS performance, impact tests using the EEVC legform were conducted. In tests set up to induce shearing in the PMHS, tibia acceleration was found to be a significant factor in causing tibia fracture. However, the acceleration was not used for the estimation of fracture tolerance due to the means of its estimation, from film analysis. Matsui suggested that shearing displacement can be treated as a significant factor to determine the risk of ligament damage but the bending angle and bending moment cannot be used when estimating the risk of ligament damage. For the shearing set-up, the EEVC legform did not exhibit a biofidelity in its response to fit with the responses of the PMHS. Only in the bending tests conducted at 20 km/h did the EEVC legform fit with the responses of the

PMHS. To obtain a scaled risk curve of impact force for the EEVC 2000 legform impactor (i.e. WG17 version with shear damping) from the tolerance of PMHS, Matsui applied a transfer coefficient of 1.38. With this scaling, using the EEVC legform, a 6.9 kN impact force produces a fracture with a probability of 0.5. For the shearing displacement, the transfer coefficient was 0.314. This produced the value of 7.9 mm of shearing displacement as assessed by the EEVC legform, causing ligament injury with the probability of 0.5.

As discussed in Section 3.1.1.1, none of the above studies include the effects of muscle tension on knee joint lateral bending moment. However, the following conclusions can be drawn from the above studies:

- The legform impactor gives a different result to PMHS tests; however, this is not surprising since the knee bending moment as discussed in Section 3.1.1.1 is far higher in the EEVC impactor than found in most PMHS tests (to account for muscle tension in live humans).
- That, as with many test tools, a transfer function can be used to take account of the necessary differences between the test tool and real life.
- The current phase two EC Directive performance criteria are broadly supported for an injury risk of 20 percent.

One alternative to obtaining biomechanical data from PMHS tests to set both impactor characteristics and performance criteria is the reconstruction of real pedestrian accidents. By reconstructing well-documented accidents with the test tool, injury risk curves for living humans can be derived and this method also has the advantage that it includes the transfer function for any differences between the test tool and humans. Where injuries are caused by metal parts of the car (such as the bonnet top or bonnet leading edge) the severity of the impact can be matched in the reconstruction by reproducing the dents found in the accident. In this case the accident investigator's estimate of the impact speed is used as a starting point but it may be adjusted slightly up or down until the damage is matched. However, for reconstructions of bumper contacts this matching is often not possible because no permanent dents are left in the vehicle. In this case random errors in estimating accident impact velocity will reduce the confidence in the risk curves but not distort them. Any systematic biases in the estimates of accident impact speed will also produce a bias in the risk curves derived from the reconstructions.

Matsui (2003) reconstructed fifteen accident cases selected from the JARI and the Institute for Traffic Accident Research and Data Analysis of Japan (ITARDA) pedestrian accident databases using the EEVC WG17 legform impactor. The data from these reconstructions were then used to define injury risk curves for the EEVC legform. For the reconstructed legform tests, it was not possible to confirm if the legform test velocity/severity matched the real accident velocity by matching the accident damage to the car. Therefore, as noted above, any systematic errors in estimating the accident impact speed would cause errors in the reconstructions and injury risk curves derived from them.

It was intended to use the transfer coefficients as derived by Matsui (2001) to the data from these accident reconstructions to generate the scaled tolerance curve for collateral ligament injury. The need for this was based on the previous results, which indicated that comparison of the magnitudes of bending angle time histories of PMHS and the legform impactor could be misleading. However, the tangents of the bending angle time histories were used to generate the scaling factor, which was found to be in the range 1 to 1.07 and for the range of bending angles corresponding to injury risks of 0.2 to 0.5, the factor was found to be 1. As this was the region of interest for Matsui, no scaling was necessary for the collateral ligament injury risk curve derived from the accident reconstructions.

The no injury cases are as important as the injury cases in a logistic injury risk analysis. Therefore Matsui grouped the fifteen cases that he reconstructed into groups with and without knee injury and groups with and without tibia fracture. This gave him four cases with and four cases without collateral ligament injury to derive his knee bending angle / knee ligament injury risk curve and seven cases with tibia fracture and eight cases without, to derive his tibia acceleration / tibia fracture injury risk curve. As the data available seemed to be rather limited, Matsui suggested that to increase the

reliability of the results, further accident reconstruction tests should be performed not only to simulate accidents reported in Japanese databases but also those investigated in other countries.

The cases selected to generate the injury risk curve for collateral ligament injury were accident cases where tibia fracture did not occur. This is important as fracture of the tibia can reduce the severity of the impact at the knee. However, it may also introduce a sample bias towards pedestrians with strong tibias or vehicles with pedestrian friendly bumper designs. As logistic regression is sensitive to sampling strategies, this would affect the injury risk curve although the extent of the effect is not known. It should also be noted that the legform bending angle in three of the four collateral ligament injury cases reached the mechanical limitation (around 30°) of the legform impactor, the effect of this would be to slightly overestimate the risk of injury at the 20 percent level with the error increasing with higher risks.

The Logistic regression injury risk curves that Matsui derived for the collateral ligament (bending angle) and tibia fracture (lower leg acceleration) for the legform impactor are shown in Figure 3.8 below. Matsui gave the 20 percent injury risk levels from these curves as 19.2° for the bending angle and 153 g for the tibia acceleration. The corresponding 50 percent injury risk values were 26.5° and 203 g respectively. The implication of these values is, for example, that the probability of a living human pedestrian receiving a collateral ligament injury is 0.2 when the EEVC legform gives a bending angle of 19.2° in a test.

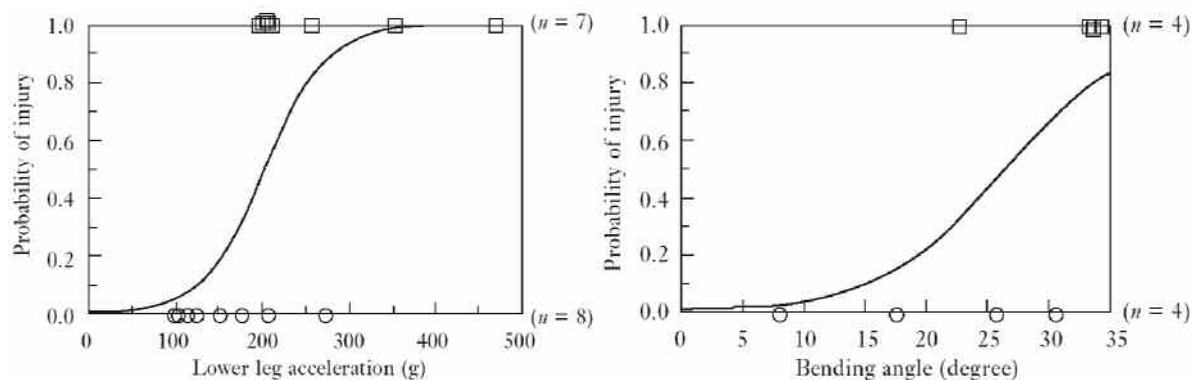

Figure 3.8. Tibia fracture and collateral ligament injury risk curves expressed by acceleration and bending angle using the EEVC legform impactor (Matsui, 2003)

As already noted, the data used to derive these curves was rather limited and any systematic bias in the reported accident speed will also have biased the risk curves. Nevertheless, it is thought important to have values that take into account the differences between live and PM humans and also to have a transfer function for the differences between the test device and a human. Therefore, overall, these reconstructions are thought to represent the best current data. As a result, it is likely that the 20 percent injury risk value of about 19 degrees is a more appropriate value for use in the second phase of the EC Directive. However, given the limitations of this data it might be more prudent to select a slightly lower value or alternatively use 19 degrees as the limit and rely on the additional margin of safety added by manufacturers to reduce this to about 14 or 15 degrees in practice. As with the other data on tibia fracture risk, these accident reconstructions confirm the current 150 g acceleration performance criteria for the second phase.

3.3.2 High bumper test

The Japanese Automobile Manufacturers Association (JAMA) have expressed concern that for vehicles whose bumper position is higher than of the legform impactor's overall centre of gravity, the impactor often slides under the vehicle. This is unrealistic and might result in the approval of designs that could aggravate injuries to pedestrians and other vulnerable road users if the vehicle structure is modified to comply with phase two of the EC Directive. They suggest that this "sliding" behaviour is

interpreted as a better leg protection performance according to the phase two standard. In the real world it will probably not help to reduce injuries. Consequently, JAMA believes it necessary to modify the WG17 test procedure and standard values so as to select measures more appropriate for the reduction of pedestrians' leg injuries.

This matter was considered by EEVC WG17 in selecting the height of the lower bumper reference line at which the switch to the high bumper occurs. They used a study by EEVC WG10 that had shown that an upper body mass was not necessary for vehicles where the bumper impact occurred at or below the knee joint. The legform impactor emulates a 50th percentile adult male; the height of the impactor's knee and the height of its overall centre of gravity are 494 mm and 553 mm respectively. EEVC WG17 considered these heights along with the results of the WG10 study and decided to select a lower bumper reference line at a height of 500 mm as being the appropriate point at which to switch the test to an upper legform to bumper test. For cars, bumper standards such as Part 581 set out that the centre of the bumper test face used to impact the bumper is required to be at any height between 16 and 20 inches (406 to 508 mm). For cars, the bumper top edge is designed at a fairly consistent height of about 500 ±50 mm, with the depth of a typical bumper being about 100 to 200 mm. The practical effect of this is that the centreline of car bumpers will be at or below the impactor knee height and therefore no upper body mass is needed. For vehicles with high bumpers it may be argued that the switch might have been better made at a slightly lower height than the 500 mm chosen by WG17, to be sure that the lack of an upper body mass did not affect the results. However, as discussed in Section 3.3.1.3 it is recommended that at first contact, the height of the 'foot' end of the impactor above the ground reference level be increased from zero to 25 mm to allow for the typical thickness of a shoe. This will mean that the height of the knee of the impactor relative to the ground will be 519 mm (494 + 25 mm) and the height of the overall centre of gravity of the impactor will be 578 mm (553 + 25 mm). Therefore, the current switch point of 500 mm becomes more appropriate.

Currently, both the first and the second phases of the EC Directive allow the manufacturers of vehicles with 'high bumpers' to select whether the bumper is to be tested with the upper legform impactor or the legform impactor. The absence of an upper body mass on the legform impactor means that for high bumpers, the kinematics of the legform will not be the same as for a live human. Despite this the choice of test was allowed by WG17 because it was thought that measures introduced to meet the legform requirements would still be effective in reducing the injury risk of high bumpers in real life. In general TRL concurs with this conclusion; however, taking into account the concerns of JAMA that some solutions might aggravate injuries to pedestrians and other vulnerable road users, it is recommended that the switch to the upper legform to bumper test be made compulsory.

The upper legform to bumper test requires the impactor to be centred about the bumper upper and lower reference lines. Originally the upper bumper reference line was only used to determine the bumper lead, which is used in turn to determine the impact conditions for the bonnet leading edge test. In the determination procedure, the 700 mm straight edge length and the end of the straight edge 'on the ground' requirements were introduced so that for flat fronted vehicles with no identifiable bumper, the height of the line was restricted to a reasonable bumper type area. However, when the reference line is also used in the upper legform to high bumper test, instead of always marking the top corner of the bumper on a vehicle with a high bumper, as intended, it can mark a lower point, because the top end of the straight edge makes contact. For a vehicle with an extremely high bumper we could have a lower bumper reference line within 23.5 mm of the upper reference line. This would result in the upper legform to bumper test not being centred about the 'real' bumper front face. To overcome this problem TRL recommended to EEVC WG17 that the following change be made to their test methods:

“The Upper Bumper Reference Line identifies the upper limit to significant points of pedestrian contact with the bumper. For vehicles with an identifiable bumper structure it is defined as the geometric trace of the uppermost points of contact between a straight edge and the bumper, when the straight edge, held parallel to the vertical longitudinal plane of the car and inclined rearwards by 20 degrees, is traversed across the front of the car whilst maintaining contact with the upper edge of the

bumper. For a vehicle with no identifiable bumper structure it is defined as the geometric trace of the upper most points of contact between a straight edge 700 mm long and the bumper, when the straight edge, held parallel to the vertical longitudinal plane of the car and inclined rearwards by 20 degrees, is traversed across the front of the car, whilst maintaining contact with the ground and the surface of the bumper. See Figure 1a.”

Note that the second paragraph of 2.2.1 (in the EEVC WG17 test methods), about shortening the straight edge, is no longer necessary. We suggest that Figure 1a is changed to show the more common case of a stick not in contact with the ground.

The working group agreed to accept these changes in principle; however, there was some concern that the TRL solution might introduce some unforeseen new problems. Therefore the industry members of WG17 currently have a task to consider the fitness of the TRL proposal or to propose an alternative solution. It is recommended that either the upper bumper line definition be amended or that the rule for centring the upper legform impactor be revised in the second phase of the EC Directive, but before making this change the opinion of EEVC WG17 should be requested.

When examining off-road vehicles it was observed that some had a rigid towing eye or loop fixed below the bumper front face, in such a position that it would not be involved in an upper legform to bumper test, yet where it could be injurious to a pedestrian. It is recommended that where towing eyes are positioned beneath a high bumper, in such a position that they are not contacted by the upper legform impactor, that they be set back at least 120 mm behind the front face.

3.3.3 Upper legform test

3.3.3.1 Upper legform tool

No alternative upper legform test tools are available and no modifications to the EEVC impactor have been suggested. Therefore, no changes to the test tool are recommended for the second phase of the EC Directive.

3.3.3.2 Upper legform certification

The effects of humidity on the performance of Confor™ foam has been discussed in Section 3.3.1.3. The study by Matsui (Matsui and Takabyashi, 2004) includes drop tests onto samples of Confor™ and these results show that it is the Confor™ foam itself that is affected by humidity. The upper legform certification test is thought to be less sensitive than the legform dynamic certification test to acceptable changes in the performance of Confor™ foam. Therefore, it may not be necessary to introduce a humidity tolerance. Nevertheless, car manufacturers give a high priority to minimising test variability, so the extra cost of controlling humidity in the upper legform certification and vehicle tests may be considered cost-effective. Therefore, it is recommended that some consideration should be given to introducing a similar humidity tolerance to that proposed for the legform test. Applying these tolerances to the upper legform certification and vehicle tests will reduce further any variability for this tool. Therefore, it is recommended that some consideration should be given to introducing a tolerance of $35 \pm 10\%$ of relative humidity to the upper legform certification requirements in the second phase of the EC Directive.

3.3.3.3 Upper legform test method

For the upper legform there is nothing available to borrow from other test methods, as there are none. However, TRL have produced recommendations to revise the current test energy curves based on a more biofidelic pedestrian model and improved vehicle model (Neale *et al.*, 2001) than that used by EEVC WG17 to specify the current energy look-up curves. In the fifteenth meeting of EEVC WG17 the new energy curves proposed by TRL were considered. The main focus of this was to see if the

new curves were more consistent in terms of required test energy when typical errors in measured bumper lead and bonnet leading edge height were introduced. It should be noted that the straight edge method used to mark vehicles for the EEVC test methods will be sensitive to errors where the surface of the vehicle is relatively flat in the area where the straight edge makes contact. EEVC WG17 concluded that the new curves (see Figure 3.9) were far less sensitive to these marking-up errors and were therefore more robust.

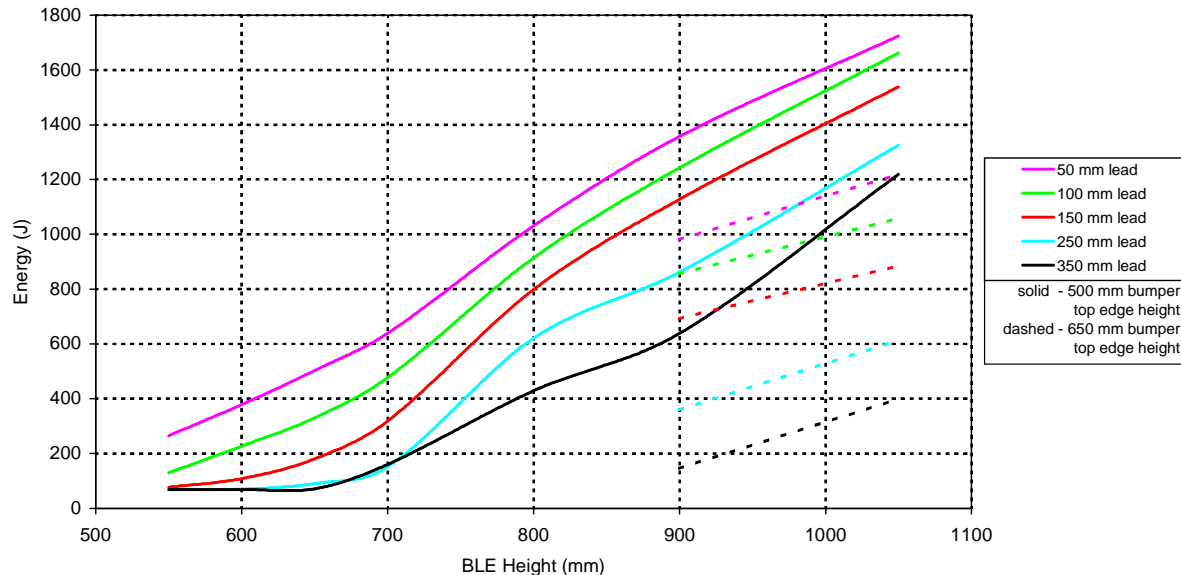
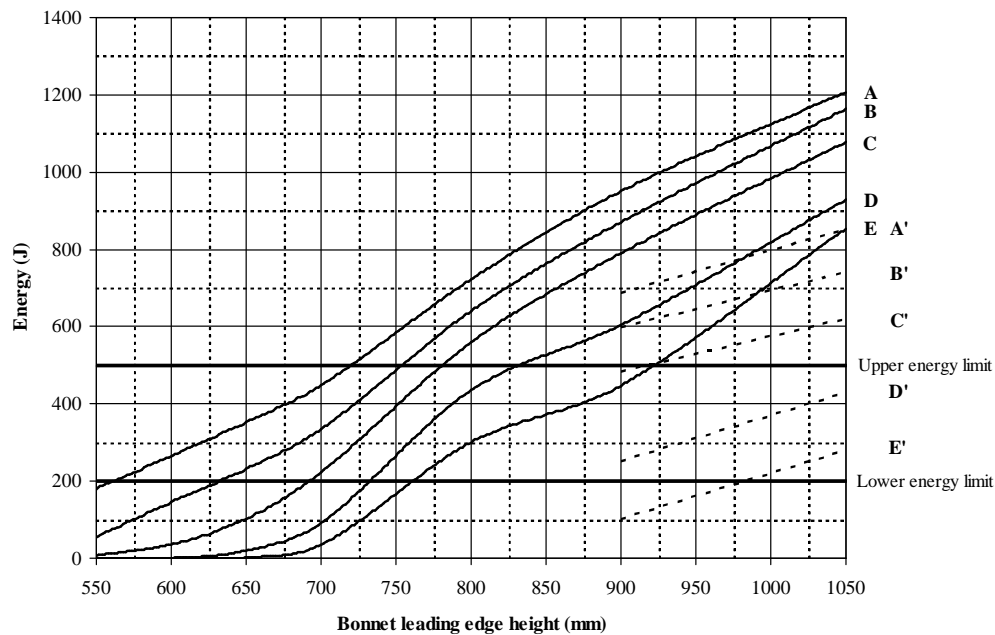

Figure 3.9. Proposed upper legform impact energy curves for use with a straight edge at 40° to the vertical (Neale *et al.*, 2001)

However, it was also noted that these energy curves required slightly higher energies for many car shapes than the previous ones. The working group went on to discuss the appropriateness of the test energies when compared with the comparatively low injury rates for bonnet leading edge impacts found in accident studies and the high failure rates seen when current cars are tested. One reason why older cars fail the upper legform test, yet relatively few femur and pelvis injuries are seen in real world accidents, compared with lower leg and head injuries, is that the upper legform test energies were found in conjunction with a theoretical pedestrian friendly bumper. With a pedestrian friendly bumper, due to the low stiffness and allowable crush depth, the pedestrian's leg will be propelled up towards car speed gently and as it penetrates into the bumper, therefore the bonnet leading edge contact with the upper leg will be comparatively severe. However, most current vehicles have a comparatively hard bumper due to the presence of a strong bumper beam. Therefore, in many current real world accidents, a hard bumper contact, typically just below the knee, will start to sweep the pedestrian's upper leg up to vehicle speed before the bonnet leading edge makes contact. Also the bumper is likely to cause fractures of the bones below the knee or knee ligament failure. The effect of this additional hinge is to reduce the effective mass of the upper leg when the bonnet leading edge strikes it. As a lower force is required to propel a reduced mass up to vehicle speed, the risk of upper leg injury is reduced if the bumper causes fracture or knee joint failure. Because of these two effects of hard bumpers on bonnet leading edge impact severity, the upper leg test can be said to represent more of a 'worse case' than occurs with most current cars, but it would be more appropriate for cars with a pedestrian friendly bumper. As the intention of the EU Directive is to save injuries to the knee and lower leg by requiring softer, safer bumpers, then the test energy for the upper legform should be appropriate for a pedestrian friendly bumper. Although the working group accepted this argument they concluded that the current gap between test severity and injury rates for the bonnet leading edge was too large to be caused by the effects of hard current bumpers. It was therefore agreed that whilst the trends of the latest TRL energy curves were more appropriate, some adjustment of their absolute values was needed.

The TRL study also included some tests of the sensitivity of the energy predictions in terms of energy for one vehicle shape with a 700 mm high bonnet leading edge and a 150 mm bumper lead. For this vehicle shape it was found that some improvements to the pedestrian and vehicle models resulted in an increase in energy and one reduced it, resulting in a net increase in bonnet leading edge energy. A rational explanation could be found for each change with, for example, a more natural walking stance lowering the pelvis and upper body height by 20 mm and thereby increasing the effective mass seen by the bonnet. However, for the higher vehicle shapes the changes to give the pedestrian model greater biofidelity produced a reduction in test energy of about 30 percent. It would seem reasonable to assume that further changes to give the pedestrian model greater biofidelity by for example introducing more joints in the spine and connecting the mass of the muscle, internal body organs, digestive system, etc. more loosely to the skeletal frame would reduce the bonnet leading energy by a further similar amount. Therefore it is proposed that the new test energies, shown in Figure 3.9, be adjusted, as agreed in principle by WG17, by introducing a 30 percent reduction. Some additional minor adjustments have also been made. The original allowance for the energy absorbed in the flesh of the impactor has been progressively removed for the more streamlined car shapes, where the test energy is too low to fully crush the impactor flesh.

The proposed revised curves, along with a set of interpolation rules, are shown below in Figure 3.10. The new energy curves include an upper energy limit that has been reduced from 700 to 500 J; the need for this is discussed in Section 7.2.3.4. A further conclusion made by Neale (2001) was that the angle of the straight edge used to determine the bonnet leading edge reference line should be changed from 50 degrees to the vertical to 40 degrees, in order to identify more accurately the centre of the upper leg impact. It is recommended that this be adopted for phase two of the EC Directive; therefore the energy curves in Figure 3.10 are appropriate for a 40 degree straight edge angle. With the current WG17 curves, the points with the high bumper at a BLE height of 1050 mm happened to be consistent with the trend for low bumpers at BLE heights up to 900 mm. Since most cars with a 900 mm BLE height have a low bumper and most with a 1050 mm BLE height have a high bumper it was possible to combine the low and high bumper data into a single set of curves, in order to simplify the look-up method. However, with the proposed curves the low and high bumper data give quite dissimilar impact energies, so it is now necessary to keep the low bumper and high bumper energies as separate curves and lines. This will also allow appropriate test energies to be obtained for vehicles with a high BLE and a low bumper; this combination would arise if a bumper is designed to be automatically or manually moved between a high off-road position for a higher ramp angle and a low on-road position for greater pedestrian safety and compatibility with other cars.



Key:

- A & A' = 50 mm bumper lead
- B & B' = 100 mm bumper lead
- C & C' = 150 mm bumper lead
- D & D' = 250 mm bumper lead
- E & E' = 350 mm bumper lead

Notes:

- For vehicles with a bumper top edge height of less than 575 mm:
 - Interpolate vertically between the solid curves.
 - With bumper leads below 50 mm - test as for 50 mm.
 - With bumper leads above 350 mm - test as for 350 mm.
 - With bonnet leading edge heights above 1050 mm - test as for 1050 mm.
- For vehicles with a bumper top edge height of 575 mm or greater:
 - Interpolate vertically between the dashed lines.
 - With bumper leads below 50 mm - test as for 50 mm.
 - With bumper leads above 350 mm - test as for 350 mm.
 - With bonnet leading edge heights above 1050 mm - test as for 1050 mm.
 - With bonnet leading edge heights below 900 mm - test as for 900 mm. However, if the energy thereby obtained is greater than for a vehicle with a bumper top edge height of less than 575 mm, test as for a bumper top edge height of less than 575 mm.
- With a required kinetic energy above 500 J - test at 500 J.
- With a required kinetic energy below 200 J - no test is required.

Figure 3.10. Upper legform impact energy curves for use with a straight edge at 40° to the vertical (proposed for use in phase two of the EC Directive)

As discussed above in Section 3.3.3.2, it may be beneficial to introduce a humidity tolerance in the upper legform vehicle test in order to reduce the variability. Therefore it is recommended that some consideration should be given to introducing a tolerance of $35 \pm 15\%$ of relative humidity to the upper legform certification requirements in the second phase of the EC Directive.

There have been some criticisms of the upper legform test method because it fails to reproduce the rolling effect of a pedestrian in contact with the bonnet leading edge, and because there appears to be some conflict between accident data and the results of tests on modern cars, as discussed above. Both these matters were addressed in EEVC WG17 Document 35 (Lawrence, 1998), which explains the philosophy of the upper legform impactor and of the test method used to assess the safety of a car's bonnet leading edge. The extract below from the EEVC working group document covers the reason why it was not thought necessary to include this rolling action in the test method.

Accident data show that the first contact is most often between the pedestrian's lower leg and the bumper, with the pedestrian side-on to the car. This contact starts to sweep the pedestrian's legs from under him or her. The next contact is normally between the upper leg and/or pelvis and the bonnet leading edge. However, the first contact between the bumper and lower legs will affect the nature of this second contact with the bonnet leading edge. The extent to which the bumper contact affects the bonnet leading edge impact is very dependent on the vehicle geometry.

To examine the effect of car shape on the nature of the bonnet leading edge impact, a series of full-scale experimental impacts between a pedestrian dummy and a range of car shapes was carried out (Lawrence, 1990). The simulated car used for these tests was full size and was covered in a layer of energy absorbing foam. This foam made it possible to make direct measurements of contact forces, because the inertia of the foam deformed in the impact was negligible. In this study the energy absorbing properties of the simulated car were selected to be approximately appropriate to provide pedestrian protection.

Examination of the high speed films and transducer outputs from the full scale tests made it possible to determine the movements of the dummy throughout the impact and also, more importantly, during the phase of contact when significant forces and accelerations were generated by the bonnet leading edge contact.

The examination of the high speed films of pedestrian impacts shows that for many car shapes the initial bumper contact starts to sweep the pedestrian's feet from under him or her before the bonnet leading edge impacts. This means that the struck side leg is often not vertical at first contact with the bonnet leading edge. On making contact with the bonnet leading edge the pedestrian continues to roll (and possibly slide) around the bonnet leading edge (BLE). This rolling effect was found to be more marked with the more streamlined car shapes.

Some consideration was initially given to reproducing rolling in the sub-systems test, however, the mechanism required to produce this effect in a sub-systems impactor would need to initiate rotation before impact with the bonnet and was considered to be unacceptably complex. The alternative, of producing this rolling effect in a free flight impactor was also considered and it was concluded that it would need to include a leg section to initiate rolling on contact with the bumper, an instrumented femur section to strike the bonnet leading edge and an upper body section to represent the mass and inertia of the upper body. Clearly such an impactor would be very complex and would not meet the mandate for EEVC of producing a sub-systems impactor.

The full scale test data was therefore examined to see if it was necessary to reproduce this rolling effect. When the time histories from the force transducers in the bonnet leading edge and from the accelerometer attached to the femur were compared with the film data it became clear that the bonnet leading edge contact occurred in two phases. Initially, during the main contact the femur was accelerated up to car speed in a comparatively short time, the highest forces and accelerations were found to have occurred in this phase. Secondly, the femur was held against and continued to roll around the bonnet leading edge as that contact started to move the upper body mass; the contact force in this second phase was found to be comparatively small. These two phases were found to overlap to some degree. By using the times taken from the bonnet leading edge force time histories, the angle of

the leg was measured from the film at the start and end of the first phase of contact when injury is most likely to occur. These angles are shown in Table 3.4. These start and end times were taken as the time at which the resultant force rose to 40 percent of the peak value and the time at which it fell below 40 percent of the peak force in order to establish the change in angle over the time when there was a significant contact force. Typical bonnet leading edge fore/aft force and upper leg acceleration time histories are shown in Figure 3.11.

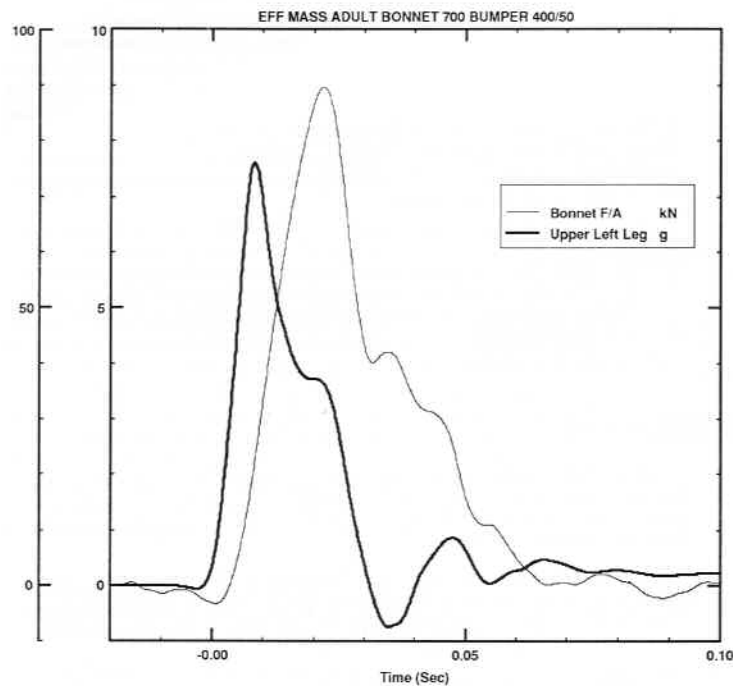

Figure 3.11. Typical for/aft force and upper leg acceleration measured in full scale experimental impacts between a pedestrian dummy and a range of car shapes

Table 3.4 also gives the angle of the resultant impulse on the bonnet leading edge (calculated by integrating the fore/aft and vertical BLE forces), also taken at the start and end of the main impact. These angles of resultant impulse have been used in preference to calculated values of instantaneous resultant force because they give very similar values, but are less susceptible to the effects of mechanical vibrations (in the steel frame of the test trolley) on the measured force. Table 3.4 shows that for all car shapes the rolling that occurs during the main impact has little effect on the angle of the resultant impulse on the bonnet leading edge. From these results it can be concluded that much of the rolling around the bonnet leading edge, seen in high speed films of tests, takes place before and after the main impact (total rolling angles approaching 90 degrees are typically seen). For most car shapes the change in the angle of the resultant bonnet force (impulse angle) during the main impact is insignificant. Because the effects of rolling were found to be small in the phase of the contact when both the injuries occur and the bonnet is deformed, it was concluded that it was not necessary to reproduce this effect in the sub-systems test.

As described in Section 3.3.3.4, TRL have carried out a large number of accident reconstructions with the upper legform impactor. In these reconstructions a 'good match' to real accident car damage was achieved with the sub-systems impactor, this also supports the conclusion that it was not necessary to include this rolling action in the test method.

Table 3.4. Upper leg angles and bonnet leading edge impulse angles found in full scale tests, for a range of car shapes

BLE height (mm)	Bumper lead (mm)	Upper leg angle during main BLE impact, from film (degrees)			Angle of bonnet leading edge impulse during main impact (degrees)		
		Start	End	Difference	Start	End	Difference
700	50	7	42	35	17	27	10
700	150	10	45	35	32	34	2
750	50	13	29	16	19	28	9
750	150	22	39	17	38	35	-3
850	50	4	12	8	n/a	n/a	n/a
850	150	17	26	9	33	25	-8

It can be seen from the analysis in EEVC WG17 Document 35, summarised above, that the need to reproduce the pedestrian's rolling action was considered in some depth by EEVC. It is clear that the upper legform sub-system test is a simplification of a real-life accident, however, the analysis shows that it takes account of those aspects of the rolling and sliding action of the pedestrian that significantly affect the nature and severity of the bonnet leading edge loading. Appropriate simplifications of the type used in this test have many benefits when used in regulations to require certain minimum standards of protection, including being more repeatable, easier to design for and providing appropriate protection for a wide range of accident situations (variations in pedestrian stature, direction of motion etc). Therefore it has been concluded that it would be inappropriate to add to the complexity of the test method by introducing a 'rolling action' that would not improve the protection provided.

3.3.3.4 Upper legform criteria

Matsui *et al.* (1998) conducted upper legform tests on 15 production cars. These were evaluated against the EEVC WG10 performance criteria of having a total force of less than 4 kN and a bending moment of less than 220 Nm, and used the WG10 test parameters, which for most cars require higher test energies than the WG17 test parameters. None of the test results met the requirements and the results from the three EEVC component tests, indicating that the upper legform impact test had the most difficulty fulfilling the requirements of the performance criteria. With their review of pedestrian accident data, Matsui *et al.* observed that the number of severe femur and/or pelvis injuries caused by the bonnet leading edge is smaller than that of the other severe injuries caused by the bonnet or bumper. This led to the suggestion that when considering the priority of the pedestrian test procedure, the upper legform impact test should be the lowest among the three subsystem tests. To validate the injury criteria for the legform impact test, Matsui *et al.* used the upper legform impactor and numerical simulations to reconstruct pedestrian accidents selected from the Japan Automobile Research Institute (JARI) database. In order to understand the relationship between measured physical values and injury severity, the best 12 cases were selected from the accident reconstruction tests. Initially, the impact force was plotted against the bending moments and it was concluded that the indication was that the current injury criteria gave a 0 percent possibility of causing an injury of AIS 2+ severity. A Weibull cumulative frequency curve was made from the accident reconstruction tests to establish the injury criteria for femur or pelvis AIS 2+ injuries, for both impact force and bending moment. These curves set the 0 percent frequency limits to be 4 kN and 220 Nm, as these

probabilities had been determined earlier in the paper. The revised impact force and bending moment levels corresponding to a 50 percent chance of sustaining an AIS 2+ femur or pelvis injury were then determined to be 7.5 kN and 510 Nm and for a 20 percent level, 6.3 kN and 417 Nm, respectively.

The method used and the assumptions made to produce the upper legform injury risk curves by Matsui *et al.* (1998) were considered by EEVC WG17. They had several concerns about the approach used by Matsui, the two most important concerns were that the Weibull analysis produced an injury distribution rather than an injury risk curve and that the values selected to set the zero injury risk were too high.

Therefore TRL went on to conduct a further 23 upper legform accident reconstructions and combined these with the original 12 Matsui (JARI) tests and a further 4 newer reconstructions by Matsui to produce a larger dataset. TRL then carried out normal and Logistic injury risk analysis to produce the injury risk curves used by EEVC WG17 to select the values currently in the second phase of the Directive. As TRL were able to match the damage (dents) in the vehicles concerned, these results are not dependent on the accuracy with which the investigators could determine impact velocity. They also include a transfer function for any differences between the impactor and its instrumentation and a living human. Due to these factors and the comparatively large sample size these injury risk curves are regarded as the best currently available data.

3.3.4 Headform test

The differences between the EEVC headform test methods (included in the second phase of the EC Directive) and the alternative test methods and tools have already been discussed in Sections 3.1.3 and 3.2.3; with the exception of the headform mass, no changes to the EEVC test methods have been recommended.

3.3.4.1 Headform tools

Based on the discussion on effective mass in Sections 3.1.3 and 3.2.3 and the decision in the 15th meeting of the EEVC WG17 that they had no objections to adopting a 3.5 kg mass for testing the child area, it is recommended that a 3.5 kg headform should be used to test the child area in the second phase of the EC Directive. It is recommended that the 3.5 kg headform specification and certification requirements in the first phase of the Directive should replace those currently in the child headform section of the second phase of the Directive.

As noted earlier the slightly heavier EEVC adult mass is supported by kinematics (body mass acting through neck) and PMHS reconstructions, however, the possible use of the alternative 4.5 kg mass is discussed in Section 7 under feasibility issues.

3.3.4.2 Headform test method

As discussed in Section 3.2.3 no changes to the child and adult test methods are proposed apart from the change in child headform mass and the possible change in the adult headform mass.

3.3.4.3 Headform criterion

All three alternative head test methods have the same Head Injury Criterion (HIC) 1000 performance criterion. The alternative of a head injury criterion based on rotational acceleration is not considered a viable option for a regulatory pedestrian test and would be particularly difficult to use within the sub-system test methods used in the EC Directive.

4 Assessment of the development and availability of new technologies

There are a number of technologies that could be regarded as new and which could contribute to reducing the number of pedestrian and other vulnerable road user casualties (for brevity these are collectively referred to as ‘pedestrians’ in the list below). In the specification for this study these were referred to as alternative active and passive technologies. However, these names are often used in a different context so it would be of help to redefine them here.

For the purpose of this study, active systems are:

- Those that change the outcome of a potential pedestrian accident by recognising and responding in some way before contact with the pedestrian occurs. These would include systems that:
 - recognise an emergency and apply the brakes more effectively (brake assist)
 - recognise that an accident is about to occur and provide additional energy absorption on the vehicle (bumper, bonnet top and A-pillar air bags)
 - assist the driver to recognise or alert the driver to potential accidents so the driver may avoid them (smart lights that provide wider or shaped beams at potential danger points or that adapt to steering wheel inputs to illuminate around bends, and infrared systems to detect pedestrians in the dark combined with display screen or head-up displays)

For the purpose of this study passive systems are:

- Those that provide improved protection after contact with a pedestrian. These would include systems that:
 - Absorb energy by controlled deformation (as this is a normal method of providing protection for pedestrians, ‘new’ might be defined as systems that absorb energy more efficiently than current designs / materials allow).
 - Those that provide more crush space by changing the vehicle shape after first contact (pop-up bonnets triggered by leg to bumper contact).

4.1 Technology already in use

4.1.1 *Passive protection*

Following discussions with car manufacturers it appears that most are intending to use a variation of the current methods used to absorb parking and accident energy. The energy in parking and crash accidents is absorbed in boxes, channels, double skinned and single skinned panels, etc. by deformation of the metal or plastic that they are made from, through crumpling, collapsing or stretching. In addition, energy can be absorbed by the crushing of plastic foams which can be fitted between the inner and outer surfaces. These methods are being adapted to provide the required stiffness and crush depth for pedestrian protection but in addition, a more uniform stiffness profile of the structure is needed as each pedestrian test only involves a small area of the car.

4.1.2 *Active protection*

4.1.2.1 *Brake assist*

Although not designed solely for protection of pedestrians and other vulnerable road users, brake assist is a technology that comes as standard on some new cars. Studies have shown that frequently

the maximum possible deceleration is not achieved by the driver alone because he is reluctant to apply sufficient pressure (ACEA, 2004a). Brake assist is a function that interprets the manner in which a driver presses the brake pedal and if it is computed to be in a manner typical of responding to an emergency situation, the vehicle will apply more braking than the force on the brake pedal would dictate alone. Through this assistance the available braking of the vehicle, including Anti-lock Braking System (ABS) engagement, can be used to a greater extent than perhaps the driver was aware was possible. These systems support the driver and lead to reduced collision speed, or help to avoid the potentially occurring accident altogether since evasive driving manoeuvres can be performed more easily once the speed is reduced more effectively.

The efficiency of Brake Assist Systems (BAS) is related to hesitant braking performance of drivers in real world situations. The brake assistance leads to braking at the level to give the shortest possible stopping distance, even though only limited effort is provided by the driver. The brake assist efficiency is therefore the difference between real world drivers' braking and the greatest possible braking.

The effect of braking assistance on the braking performance of a car has been established by DaimlerChrysler and used in their marketing information. The published figures are that for a car braking from 100 km/h, the normal stopping distance of 73 m can be reduced to 40 m by brake assist, a reduction in stopping distance of 45 percent.

Further information on the effectiveness of BAS was requested from ACEA. The information that was received (ACEA, 2004a; ACEA 2004b) is considered, as a feature that could potentially protect pedestrians, in Section 10.

4.1.2.2 *Head-up displays*

Currently, Head-Up Display (HUD) systems are available on relatively few American passenger vehicles. The concept of HUDs is to move the important information that a driver needs to see up into their line of sight, so they don't have to take their eyes off the road. To do this, HUD systems project an image so that it appears to float in mid air, just past the front end of the vehicle. With the image at this range, the eyes of the driver do not have to refocus to see gauges and indicators, and then refocus again to see the road ahead. Studies made at the University of Berkeley, California, have found the timing between looking at dash mounted instruments and looking back on the traffic is about two seconds, whereas with a HUD in this configuration it takes only half a second. In the time it takes the driver's eyes to refocus, when travelling in free moving traffic, their vehicle may have travelled several car lengths further down the road. Wildlife, another vehicle or a pedestrian could suddenly pop out in front of their vehicle and keeping their eyes on the road may expedite the driver's reaction.

Not all information is shown on the projected display. Usually vehicle speed, indicator use and main-beam indicators and sometimes audio selection are all that are displayed. Warning indicators will also light up if a vehicle problem develops. By keeping only commonly used and important information displayed, the driver's attention stays on the road (Kerr, 2002).

As an extension of the HUD systems currently used in America, the HUD systems are advancing to project Infra-Red (IR) images of the road onto military-style see-through displays in front of the driver (Stevens *et al.*, 1998).

These HUDs were originally developed to speed up the reactions of fighter pilots in combat. With one civilian version, the apparatus works by flipping a clear screen into the field of view of the driver when night falls. An IR camera takes images of the road ahead that are projected onto the screen. This moving image is superimposed onto that which the driver can see, making it possible to see warm objects, such as people, vehicles and animals, with greater contrast and outside the range of the headlamps, improving perception and accident avoidance when the light is poor.

The system uses a second set of filtered car headlights to illuminate the scene ahead of the vehicle with Near Infra-Red (NIR) radiation. A NIR sensitive digital CCD camera, mounted at the front of

the vehicle, captures an image of the scene and exports the data to a digital signal processor which calculates the right exposure level for the camera and protects it from being 'blinded' by oncoming headlights or street lights. The processed image is then sent to the HUD display module, which projects the image onto a partially reflective element in the windscreen. By this means, the driver sees a life-sized image of the warm objects superimposed on the real view through the windscreen. The HUD image is focused at a suitable distance in front of the vehicle so that when the driver looks through the windscreen, both the NIR and normal forward view are at the same focal length. This system architecture will allow the inclusion of many other features in the future if desired, such as automatic hazard identification, navigational information, and instrumentation display, in an appropriate position.

The Cadillac DeVille, DHS and DTS were the first cars in the world to offer the technology of "Night Vision," the Cadillac name for the HUD projected IR viewing system.

The following description is a summary of the Cadillac "Night Vision" system. It uses an IR camera, which is mounted on the centre of the vehicle's grill, to intercept the thermal radiation (or heat) given off by all objects. The energy is focused on and absorbed by an array of detector elements. The resulting image travels by cable and is projected in front of the driver's windshield onto an aspheric mirror that is part of the HUD mechanism on the dash of the car. Each detector element thus becomes a pixel in the video image, producing a monochromatic image that appears in far-off focus on the lower part of the windshield, showing hot objects as white while cooler objects appear black. As a result of the aspheric shape of the mirror, the curve of the windshield does not distort the image. The result is a windshield display of the road ahead that looks like a photographic negative. With the new technology, a driver can see about 450 metres in front of him, instead of 90 metres as with regular headlights (Simon, 1998).

4.2 Technology designed for use on new vehicles

Pop-up bonnet systems triggered by bumper contact are being developed by first tier suppliers and vehicle manufacturers. These systems will provide additional crush space by pushing the rear of the bonnet up before the pedestrian's head strikes it. Ideally such systems would be reversible so that after activation they can be reset and be made operational once more at little or no cost. However, most reversible pop-up bonnets would probably need to be triggered before first contact is made with the pedestrian, to allow sufficient time for the bonnet to reach a stable deployed position before it is contacted by the pedestrian. Unfortunately, the technology to detect a potential pedestrian accident reliably is unlikely to be available by the 2005 introduction of phase one of the EC Directive. Therefore, the systems currently being developed for near-term application are likely to use irreversible pyrotechnic activation to push the bonnet up. With these devices, although it may be possible to simply reset the pop-up mechanism, the activating components will need to be replaced and the costs will be significant.

One use for pop-up bonnet systems is to integrate them into an existing vehicle model design to minimise the amount of redesign and re-engineering work needed to achieve compliance. However, due to the high cost of such systems it is thought more likely that they will be reserved for vehicles where conventional energy absorption by deformation is more difficult, such as sports cars and model variants with large engines.

Such systems need time to trigger, push-up and arrest the bonnet and this must be completed before the pedestrian's head makes contact. Both mathematical simulations and full-scale dummy tests can be used to show the time available for the system to operate. The time of head impact depends on both the impact speeds and dummy sizes.

TRL understand that both reversible and non-reversible actuators have already been developed to such a level that they are close to or have achieved the operational speeds necessary for them to be used with contact sensors.

Non-reversible actuators may be less costly and require less packaging space than reversible systems. On the negative side, inadvertent deployment associated with non-reversible systems requires parts to be replaced; the reversible systems would only require resetting.

Future systems with pre-crash sensing will enable pre-impact triggering, so that slower reversible actuators can be used. It is thought that slower systems might be easier (less expensive) to reset and it is possible that they could reset themselves automatically minimising the consequence of inadvertent deployment.

In an impact with a pedestrian, a contact trigger system would detect the pedestrian by means of sensors mounted in the bumper. Intelligent systems can determine whether the impact is with a leg-type object and take actions on that decision. Those actions might be to raise the bonnet, should it be a pedestrian impact, or lock it shut to increase rigidity of the vehicle front end, should it be a vehicle to vehicle impact. Should the bonnet be deployed, then the bonnet would be raised rapidly at the rear, typically pivoting about the bonnet catch at the front. The principal benefit to pedestrians is that this creates space underneath the bonnet, so that when hit by the pedestrian's head the bonnet can deflect into this space without hindrance from hard under-bonnet components. As most cars would not be headform tested at the very front of the bonnet (the headform test area starts at 1000 mm wrap around distance) much of the test area would have large increases in crush space due to the pop-up action. The areas at the front with the smallest increases tend to be those that are less difficult to engineer with non-deploying systems.

Many methods for lifting the bonnet have already undergone review. One consideration for selection of a lifting system is that the vehicle needs to be restored to a driveable state after the firing of the active bonnet, particularly when the triggering may have been inappropriate or completely false. Springs and motors are attractive lifting mechanisms because of the relative ease of resetting them after an accident or false trigger incident. However, if they are relatively slow to deploy they could only be viable as part of an 'active' system (i.e. with pre-impact triggering). Therefore, most current development has been of systems that extend due to rapidly expanding gas.

Replacement costs may be significant if the bonnet must be replaced as well as the lifters after each triggering. To solve this, the bonnet needs to be rigid enough to perform as intended, be stable when activated - ready for impact, not fail under impact from a pedestrian torso and not deform unless contacted. Unfortunately, these requirements may conflict with the head impact protection of the bonnet when not 'popped up,' where to be less aggressive for pedestrian impacts it should deform and absorb the energy of the impact.

The effectiveness of active bonnet systems was documented by Fredriksson *et al.* (2001). In that study, a large European car was equipped with the head protection system. This car had been tested by Euro NCAP and had passed three out of six of the child headform test points and two out of six of the adult headform test points. An active bonnet was fitted to the vehicle, comprising two lifting elements which lifted the rear corners of the bonnet, which in turn consisted of compressed metal bellows that were filled with gas from micro gas generators in the event of an accident. When the adult headform test points were re-tested with the active bonnet in its raised position, all of the tests passed the performance criterion of having a HIC value of less than 1000. The highest active bonnet HIC was 778, compared with the standard bonnet values ranging from 877 to 7056. An additional test was performed on top of one of the lifters to investigate whether the mechanism had introduced any potentially injurious stiffness and resulted in a HIC value of 774.

Further tests were performed with a complete pedestrian dummy. The bonnet lifting devices were activated at approximately 30 ms after the impact and the bonnet was fully raised at 70 ms. The bonnet remained in a raised position until the head impacted the bonnet. This confirmed that the lifting mechanism could support the torso of a pedestrian for the required period as opposed to sinking before the head impact occurred. Headform tests alone would not have been able to provide this reassurance.

Depending on the size and shape of the bonnet it might also prevent or reduce the severity of contacts with the wing edge and windscreen base areas making the protection requirements less onerous in

these areas. As a pop-up system lifts the bonnet clear of the support of wing edges and rear firewall a stronger bonnet can be used than in a non-deploying system.

A deployable protection system must be designed to work in all real-life accident situations and it is also important that it works reliably, throughout the life of the vehicle. Obviously a system that fails to detect a pedestrian accident, one that is still deploying when the pedestrian makes contact or one that fails to operate due to a malfunction will not be effective or will be less effective and, in some situations, it could exacerbate a pedestrian's injuries. These issues are discussed in Sections 5 and 6.

4.3 Technology under development

One of the fundamental issues with bumper trigger systems is fitting the time required for sensing that an impact is with a pedestrian, for triggering and then for deploying additional protection, into the limited time from first contact with the pedestrian to a potential head impact. One solution to this issue would be to increase the time from the first detection of the (impending) impact to the time where the protection is required. A further benefit of pre-impact triggering is that extra protection could be provided before impact at the bumper and bonnet leading edge, by the use of airbags, as well as pop-up bonnets or airbags for the head. Therefore, further developments of deployable protection systems have led to consideration of pre-crash sensing.

For all of these systems, there would be a concern about their behaviour when an impact with a pedestrian is close to the corner of the vehicle. These concerns focus on failure to trigger or contact with the pedestrian during deployment, due to pedestrian kinematics not planned for in the contact sensors and algorithms.

4.3.1 Active protection

Pre-crash sensing will enable energy absorbing systems to be deployed before contact with the vehicle. Potentially these would enable deploying pedestrian protection to be provided at all the dangerous pedestrian contact points on the car (bumper, bonnet leading edge, windscreen base, A-pillars, etc). These systems will be able to sample over a longer time than contact sensors and should therefore be better at discriminating real pedestrians and potential accident situations. Early warning of a potential accident contact would provide sufficient time for slower reversible deploying systems to be used. Reversible systems would reduce or eliminate repair costs if they are triggered unnecessarily; this would mean that systems that err on the side of always deploying in cases of doubt would be more acceptable.

Should the pre-crash sensing time be extended further, the possibility would then be realised for a system that can deploy in case of an accident but retract automatically should the deployment be incorrect or disadvantageous. This might also be the case for moveable bumpers and spoilers and possibly for the bonnet leading edge.

The potential protection for a pedestrian that could be offered by external airbags on the bumper and bonnet was evaluated in a preliminary investigation by Holding *et al* (2001). They found that head injuries could be reduced by a factor of five, chest deceleration could be halved and lower limbs could also be protected by suitably designed, externally mounted airbags, as long as they are correctly damped. The advantages of using airbags for the vehicle manufacturer are also significant as they would not restrict styling to the same extent as body modifications. However, to fire such airbags effectively, the sensor system must be able to determine the size of a pedestrian and the likely points of contact throughout the trajectory.

One negative aspect of activating externally mounted airbags would be the cost of deployment. Following deployment of the airbags, the vehicle owner would need to replace the airbag modules and any burst-open covers. Additionally, they would also have to replace any vehicle panels that may have been deformed by the deployment. The vehicle will need to be repaired after activation necessitating the replacement of parts such as the airbags, bumper and bonnet. External airbag

systems may be difficult to justify from a cost benefit viewpoint unless false triggering rates and / or repair costs are very low.

Also, vehicle manufacturers may be reluctant to use such systems if the potential litigation makes them responsible for any injuries from deployment whether incorrect or correct. If an airbag could be deployed in such a way as to cause the driver to crash or if the airbag could be deployed and proven to have increased the injuries a pedestrian or vulnerable road user sustained, then the benefits of such systems may be negated. In effect, it will be extremely difficult to condone any protection system that could give rise to such issues, without developing for it a very reliable triggering system that could accurately discriminate the types of impact sufficiently well to avoid injurious deployments.

However, pedestrian protection will be more difficult in some styles of vehicles such as sports cars; in this case use of these high-tech systems may be justified.

4.3.1.1 Pre-crash sensors

For a pre-crash sensor to be effective and able to avoid frequent false triggering, it needs to be able to recognise objects, separate the pedestrians and vulnerable road users from others and decide if they are going to be hit. This decision would need to cope with many factors including the vectors of the object under consideration and the car, changes in direction of the car and pedestrian and also where on the car the object will make contact.

5 Comparison of protection levels

The aim of this task is to provide a comparison of the levels of protection to be expected by the use of any alternative testing measures or new technologies that have been identified, with the expected levels of protection provided by phase two of the Directive. These comparisons are being undertaken by a number of methods, by examination of data supplied by manufacturers, by theoretical calculations and by impact testing of systems.

Car manufacturers and component suppliers were contacted requesting information on the methods proposed for use as passive and active measures for protection of vulnerable road users. A number of visits were also carried out in order to learn about the current technologies and to discuss problems encountered.

5.1 Non-deploying passive systems

Designing a non-deploying passive safety system in a vehicle involves introducing pedestrian friendly design features. However, it is often difficult to incorporate such safety measures within the design parameters of the vehicle. It has been found that the current baseline for non-deploying systems is more or less the requirement of phase one of the Directive and one of the best available examples of passive non-deploying designs is the Honda Civic. This has already been extensively tested by TRL as part of a previous project for the UK Department for Transport (Lawrence *et al.*, 2001). These tests have included headform tests using the 2.5 kg child headform at 40 km/h, as per phase two of the Directive and headform tests using a 3.5 kg headform at 35 km/h, as is required by phase one of the Directive. Possible alternative test methods for phase two were discussed in Section 3 and these included using a 3.5 kg headform. However, the Civic had not previously been tested by TRL with a 3.5 kg headform at the phase two impact speed of 40 km/h. One of the more difficult design areas for manufacturers is the line between the bonnet and wing edge, and this is one of the main features of the pedestrian protection provided by the Civic. Three impact tests were therefore carried out to this area on the Honda Civic and these will serve to provide an estimate of the protection that could be provided and how feasible it may be to meet the HIC <1000 requirement of phase two of the Directive in this area. To negate the influence of collateral damage a new bonnet, wing and wing supports were fitted before each test.

The tests were carried out using a child / small adult headform (3.5 kg) at 40 km/h (11.1 m/s). This headform was made by modifying an EEVC WG17 (1998) adult headform but it complies with all of the requirements for the 3.5 kg headform as specified in phase one of the Directive, with the exception that the position of the accelerometer seismic masses. Although the positions of these masses were slightly outside the positional tolerances of phase one, the headform was aligned such that this caused no significant error.

In addition to these tests on the Civic, knowledge from Euro NCAP tests and manufacturers will be used to assess the potential level of passive non-deploying protection and its effectiveness at meeting the phase two requirements of the EC Directive.

5.1.1 Results for the Honda Civic

The bonnet was impacted in 3 positions; the target locations were recorded relative to the rear and side of the bonnet and are given in Table 5.1. The points were chosen to be close to the points tested on the Civic by Lawrence *et al.* (2001).

The HIC values and impact velocities are also shown in Table 5.1. The acceleration time histories for the three impacts are shown in Figure 5.1.

Table 5.1. Results from testing the Honda Civic with a 3.5 kg child / small adult headform at 40 km/h

Impact location	Position of target impact point			HIC	Impact velocity (m/s)
	From rear corner of bonnet (mm)	From side of bonnet (mm)	Wrap around distance (mm)		
Front	416	11		1523	11.17
Middle	270	20		1215	11.07
Back	51	23		1510	11.14

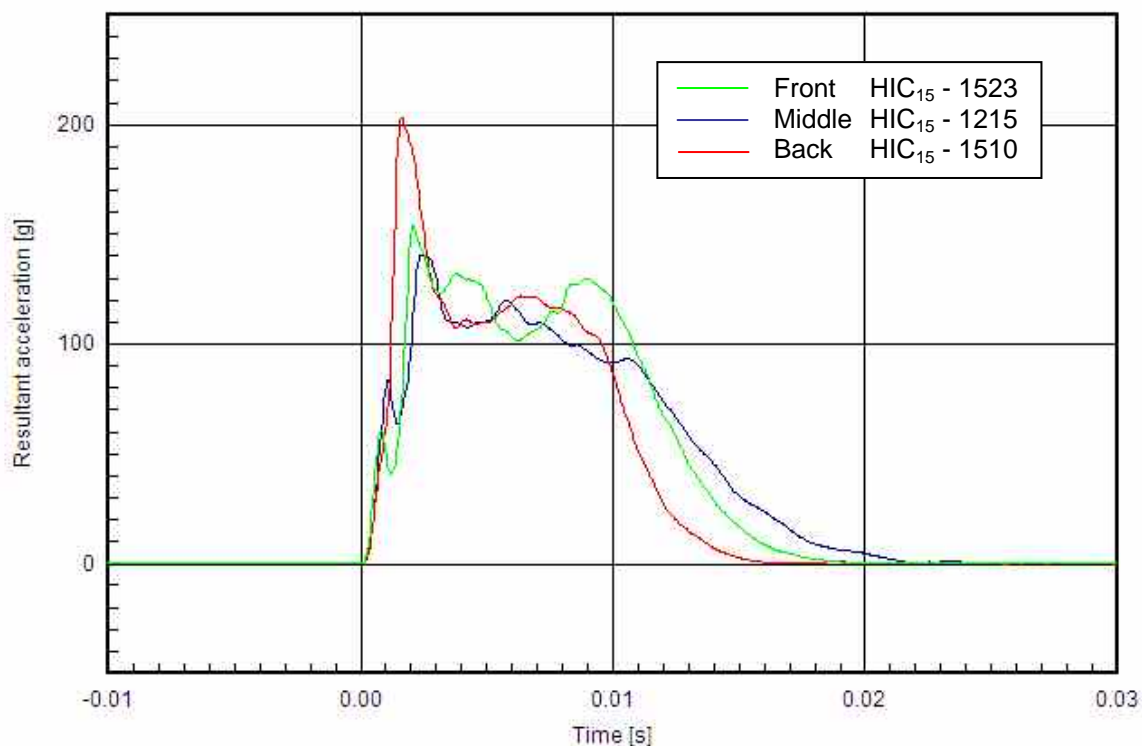

Figure 5.1. Resultant acceleration time histories for 3.5 kg child / small adult headform impacts to the front, middle and back of the bonnet / wing edge of the Honda Civic at 40 km/h

The tests to the wing edge of the Honda Civic with the 3.5 kg child / small adult headform at 40 km/h provided a benchmark for what is feasible in this difficult area.

5.2 Deploying systems

Deploying systems are designed to detect an impact and trigger a protection system that moves into a different position before the pedestrian impacts that part of a car. This movement could be the inflation of an airbag or the upward movement of a bonnet. The aim of the project was to test a number of different deploying systems; however, due to lack of test samples it has only been possible to test one pop-up bonnet system. The assessment of the system was conducted in four main areas:

- The trigger mechanism.
- Examination and testing of the deployment for reliability.

- The real-life fitness of the active device.
- Impact testing of the device using the phase two test method and possible alternatives to it.

Due to confidentiality restrictions some of these areas are not discussed further in this report.

5.2.1 *The trigger mechanism*

The trigger mechanism should be assessed using a test that simulates the human property or properties to which the trigger system is sensitive. The first tier supplier has developed a sensor integrated into a bumper that will detect impacts to the bumper. An electronic control unit (ECU) would then process the signal from the bumper and other inputs (vehicle acceleration, vehicle speed), using a defined algorithm to determine whether the bonnet should be deployed. The sensor has been tested by the first tier supplier under a number of scenarios, including using the EEVC legform. However, this has a large diameter, heavy core with less weight in the simulated flesh (compared with a human).

5.2.1.1 *TRL sensor legform*

The sensor system used by the manufacturer concerned had a number of measures that together were used to detect a pedestrian contact. From examination of this system TRL concluded that to test this system thoroughly it was necessary to use a purpose made sensor legform and not just the Directive's legform impactor. At first it might appear that the Directive legform must be suitable for testing any trigger system, but in fact the test device must be adapted to match the properties measured by sensor technology, e.g. it would have to be the correct temperature for a heat sensor. In this case it was because it was critical to produce a human-like force-time and force-distribution on the bumper face, throughout the contact. Therefore TRL decided to make a simple sensor legform to test the bumper sensor, with the aim of producing an input to the sensor system that was human-like.

The concept was to simply replicate the human leg in terms of mass distribution between flesh and bone, bone bending, knee deformation, flesh properties and flesh distribution. Drawings of the legform without the flesh are shown in Figures 5.2 and 5.3.

Particular attention was given to make the tibia human-like, however; there was insufficient time within this project to accurately match all human properties. Two possible tibia options were considered, one using a nylon bar and the other using an aluminium tube; the final choice was the nylon bar. Simplified knee ligaments were made and the waist shape was adjusted iteratively to produce a bending moment of around 300 Nm at an angle of 15°. This stiffness is somewhat weaker than the requirement for the WG17 legform and was chosen because it is important for a sensor test device to represent a wider range of accident situations than the regulatory tool. This is because a worst case regulatory tool (heavy bumper impact) will require effective protection for better cases, but a trigger system must always trigger to protect the head even if the accident situation produces a light bumper impact e.g. a pedestrian hit from behind on the back of the knee.

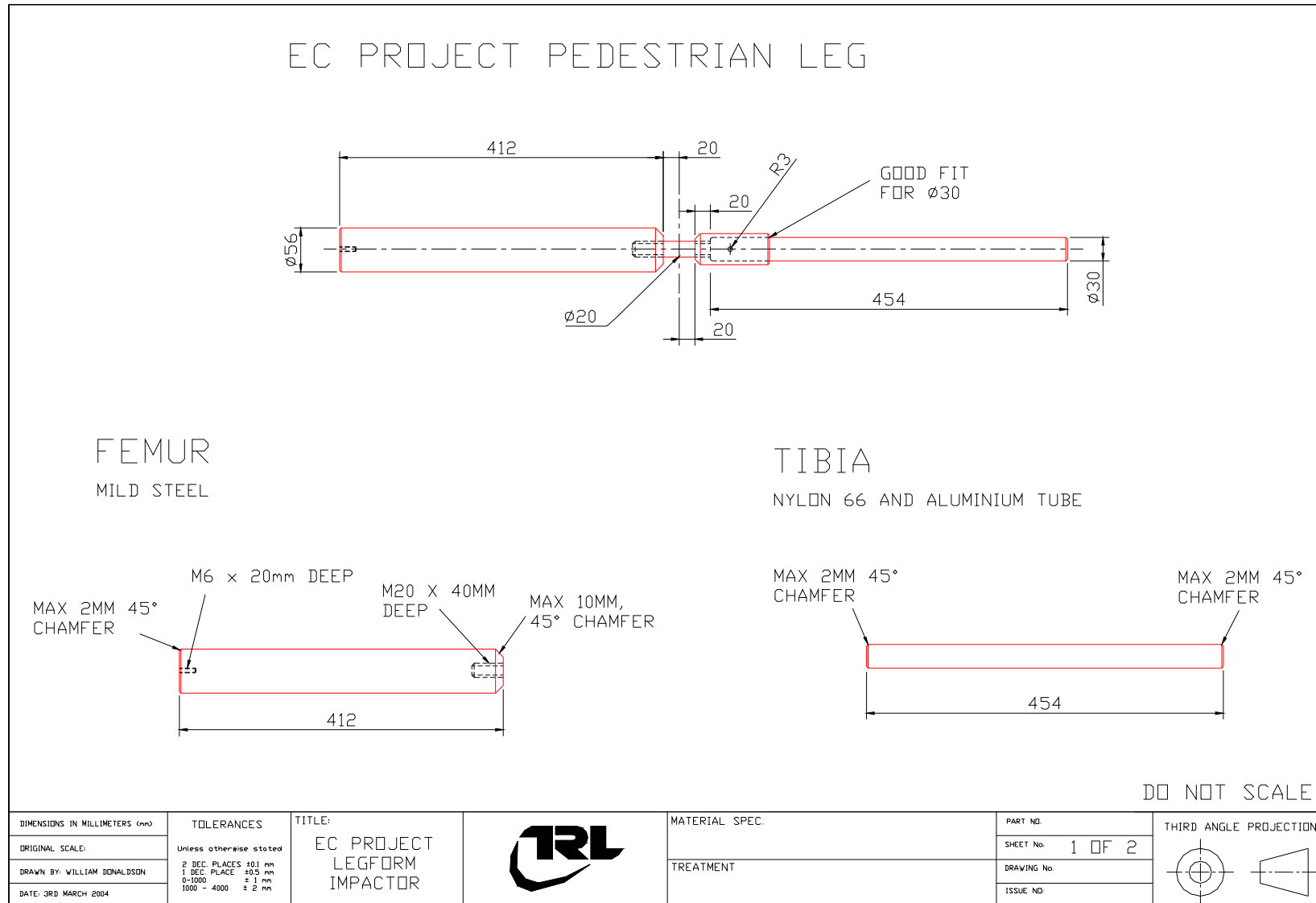

Figure 5.2. Sensor legform drawings – femur, tibia and assembly drawing of skeletal parts

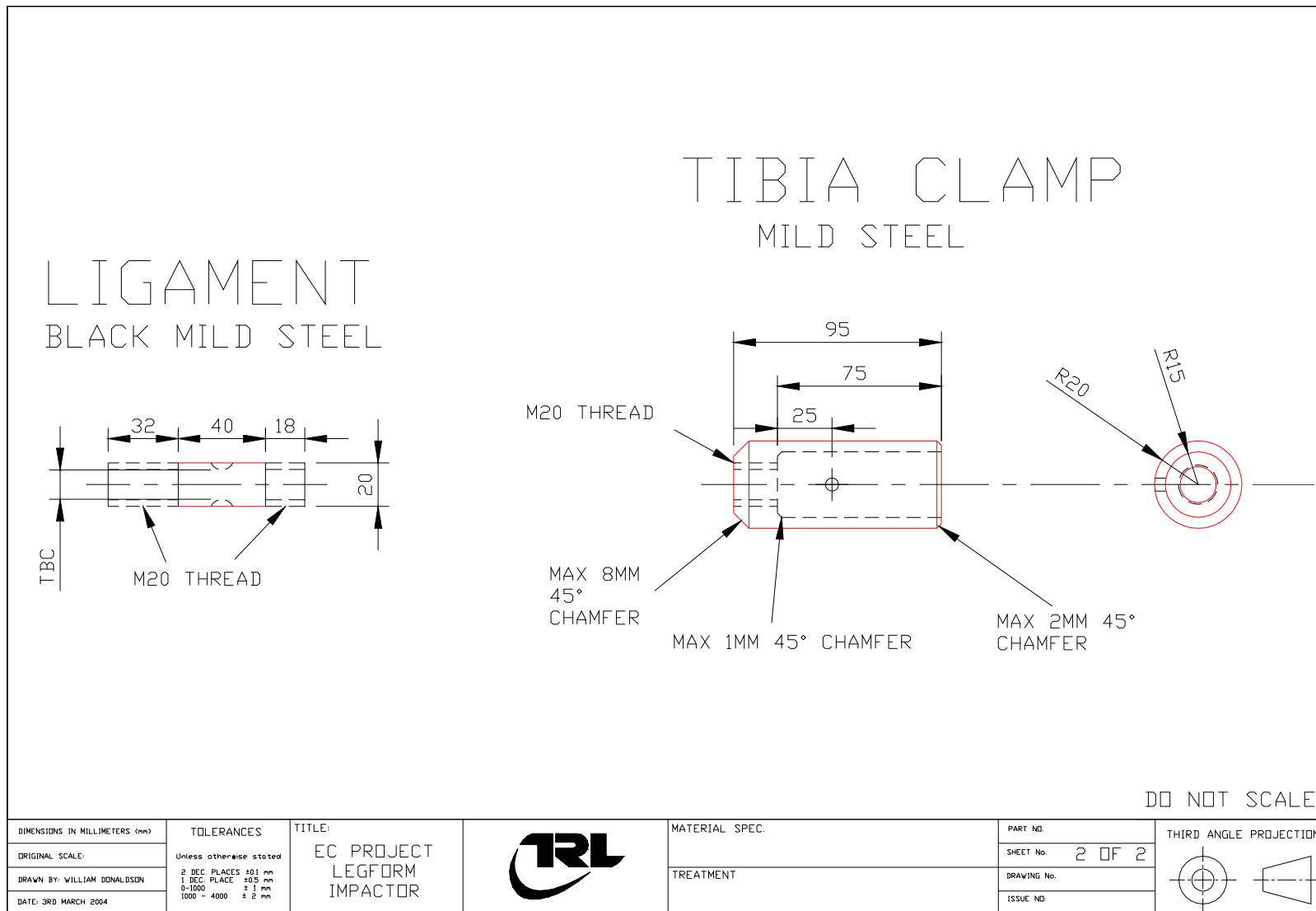

Figure 5.3. Sensor legform drawings – ligament and tibia clamp

The WG17 legform was designed with the metal skeletal structure all aligned along the axis of symmetry; however, this is not the case in a human as shown in Figure 5.4. Table 5.2 shows the leg geometry dimensions for the top, middle and bottom of the tibia. The flesh dimensions were supplied from data being used by a leg computer-modelling project at TRL. The tibia dimensions were obtained by direct measurement of a model skeleton. The tibia shaft at the top and middle is roughly kite shaped and it is more circular towards the bottom, but the sensor legform has a simple circular tibia of 30 mm diameter. The total tibia length is around 405 mm and the calf is fattest approximately a third of the way down from the top of the tibia. However, the sensor legform tibia copies the WG17 legform in being longer to include the foot (without a shoe) in the length of the lower leg. In the sensor legform, layers of Sorbothane have been used to replicate the flesh distribution around the tibia.

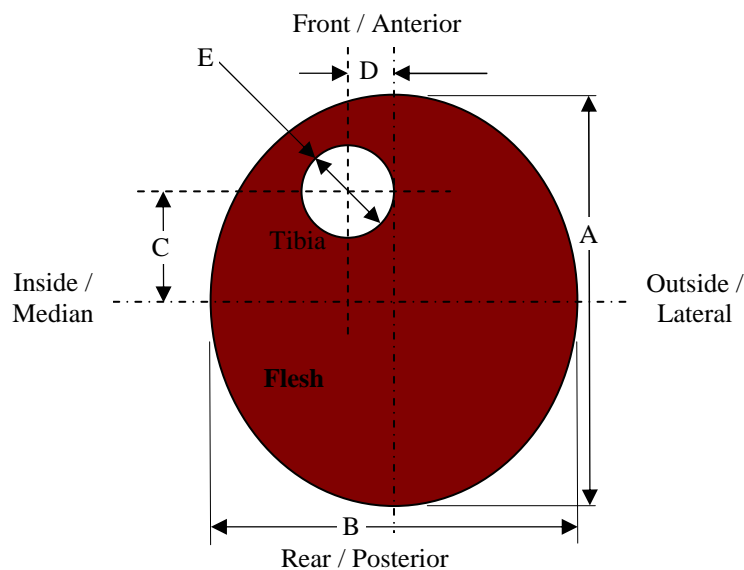

Figure 5.4. Typical cross-section of a human lower leg

Table 5.2. Typical (adult male 50th percentile) human lower leg dimensions

Dimension (see Figure 5.4)	A (mm)	B (mm)	C (mm)	D (mm)	E (mm)#
Towards the of the tibia shaft	132	116	36	15	33½ x 22½
Middle of the tibia - where calf is fattest	134	121	35	15	28 x 17
Bottom of the tibia just above the ankle	82	67	21	11	21½ x 17½

the dimensions are fore / aft by lateral

Sorbothane was chosen as it is of roughly similar density to flesh (it's denser than flesh but is much closer to flesh than the foam 'flesh' of the WG17 legform). A lower leg made using this has a much higher proportion of the mass in the 'flesh' and corresponding less in the 'bone', compared with the WG17 legform. Sorbothane is a heavily damped material, as is human flesh, so it will therefore be preferable to alternatives with less damping. In this respect it is similar to the Confor foam of the WG17 legform, but the Confor foam has a low density. The sensor legform was placed inside a WG17 legform impactor skin, to secure the 'flesh' in place.

The nylon tibia has not been tapered to try to account for the variation in the tibia dimensions along its length, but was thought to be roughly representative of the tibia in terms of bending. This means that

the exact geometry of the leg described in Table 5.2 was not copied, but the mass distribution should be better than the WG17 legform impactor.

Figure 5.5 shows the design of the prototype sensor legform lower leg flesh. This shape was made using several layers of ¼ inch (6.35 mm) thick Sorbothane sheet, glued together using heavy-duty double-sided adhesive tape. For a production sensor legform it would be possible to have the Sorbothane moulded to the required shape, in one piece. This layout simulates a pedestrian's right leg; the top of the diagram would be a pedestrian's front. The sensor legform was used with the impact on the right side in the diagram.

The 'target outer' in Figure 5.5 was the desired outer profile based on the top and middle dimensions in Table 5.2. As the legform was to be finally clad in a WG17 impactor skin, the 'target inner' was the resulting inner surface of the skin, which would then roughly be the outer profile of the flesh in Table 5.2. However, as the Sorbothane flesh is slightly heavier than human flesh, a revised 'reduced inner' profile was calculated to give the correct mass. The outer layers were gradually made shorter to approximately mimic the tapering of the lower leg flesh; only Layers 1 to 4 extend to the foot end. The equivalent inner profile for the ankle end dimensions in Table 5.2 is also shown in Figure 5.5, and this can be compared with the Layer 4 profile. Although the shape at this height doesn't match particularly well, this was adequate in an area that shouldn't be directly impacted and it also avoids unnecessary complication by keeping each layer rectangular. This arrangement was still too heavy so the outer and inner profiles were reduced slightly and the layers shaped to fit.

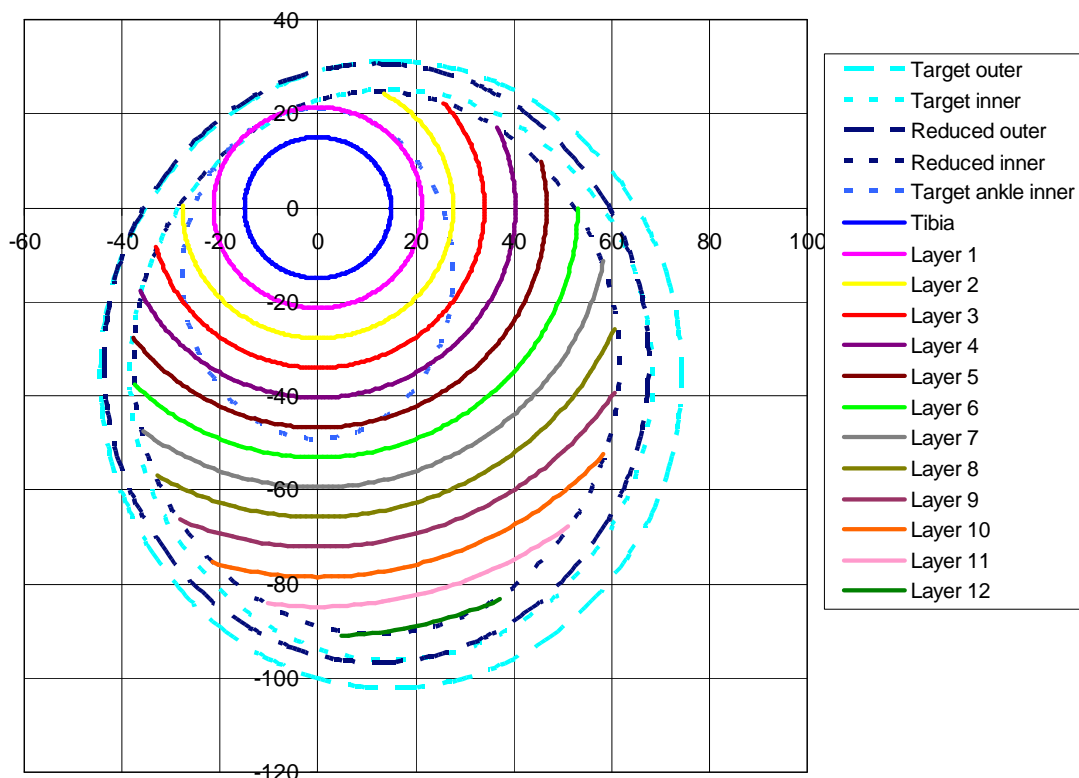

Figure 5.5. Lower leg flesh layout

As the femur section would not contact the bumper, much of the weight was concentrated in a simplified heavy steel femur section and three layers of lightweight Confor™ foam were used to roughly represent the femur flesh as shown in Figure 5.6. The strip of Sorbothane shown in the figure was used to adjust the assembled mass.

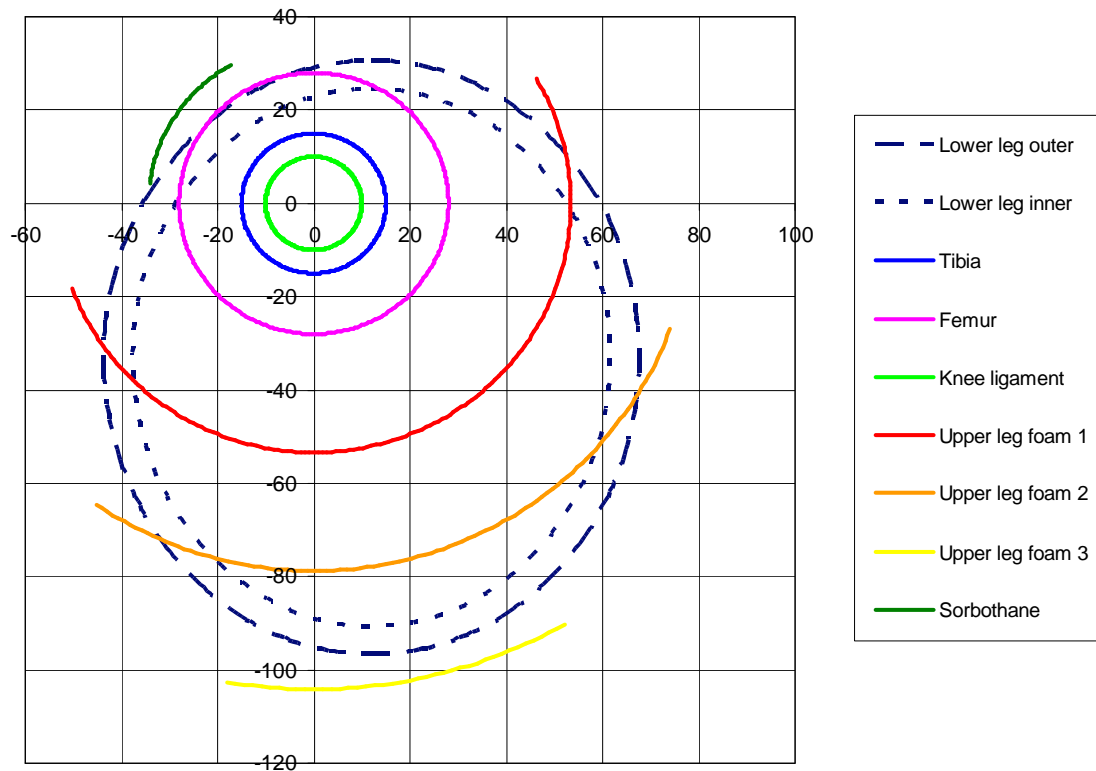

Figure 5.6. Upper leg flesh layout

The flesh was finally secured in place using cable ties, as shown below in Figure 5.7. Figure 5.8 also shows how the legform (shown without the skin layer) compares to a human leg and it is easy to see that the shape and mass distribution are much better than that of the WG17 legform.

The two halves of the sensor legform are assembled by screwing the ligaments in place.

The aim of producing the TRL simple sensor legform was to test the bumper sensor with a more human-like device so that the results could be compared with tests using the Directive legform impactor. However, there was insufficient time within this project to develop the impactor to be a good representation of a human. Therefore, any difference seen in the results of tests with the legform impactors and the more human-like sensor legform only show the need for such a device and are not necessarily typical of results that would be ultimately found with a well-developed sensor legform.



Figure 5.7. Construction of the lower leg (skin removed)



Figure 5.8. Comparison of sensor legform (skin removed) with a human leg

5.2.1.2 Results of testing with the sensor legform

Due to the shape of the sensor leg it was feared that there might be problems with its release and that it might rotate during free flight. However, with padding positioned on the launcher to stabilise the leg during acceleration, it was found that a clean release and flight was achieved. The high-speed video showed that there was in fact very little rotation of the legform during flight and it impacted at the required height. Due to the flexible tibia, the lower leg deflected around the lower spoiler causing the femur to rotate into the bonnet, producing approximately 15° of bending to the knee ligament. Due to the 'soft' impact caused by the tibia and the resulting rotation, a significantly lower force was detected in the bumper sensor.

This lower output could be significant in setting the trigger threshold. However it should be noted that the TRL sensor legform test device is a first prototype and needs further development and validation before the results can be trusted. Nevertheless, these results do suggest that the output from a human contact might be lower than those from the legform. A child version of this legform might appear to be a worst case; however, to be realistic it would need to be closer to a complete dummy because the femur and upper body of a small child may also be involved in the impact, resulting in a greater force on the bumper sensor. Therefore it is not clear what the worst case is, so it will be necessary for the worst-case pedestrian stature and build situation to be found. In this case the loads detected in the bumper may be similar to those for small objects such as dogs or chickens and thus a 'no fire' situation may occur for a human, unless an appropriately low trigger threshold was used.

Figures 5.9 and 5.10 show pictures taken from the digital video of tests using the WG17 legform and the sensor legform. The pictures clearly show the sensor leg and flesh deflecting around the lower spoiler, unlike the WG17 legform.



Figure 5.9. Bumper test using WG17 legform



Figure 5.10. Bumper test using TRL sensor legform

The signals recorded by the bumper sensor in these tests with the sensor legform were processed by the manufacturer's algorithm, which showed that it would have deployed the pop-up bonnet. The purpose of the algorithm is ultimately to determine whether the contact is a pedestrian-like impact and if so to initiate deployment of the pop-up bonnet, provided the vehicle is travelling within the speed range for deployment. The algorithm has been tested by applying modified inputs to get extreme cases and provisional deployment limits have been set. However, it's not clear from the data provided to TRL that the sensor / trigger system will work as intended in all cases including pedal cyclists. The manufacturer's assumption is that failure to fire when needed is not acceptable but some unnecessary deployments will be acceptable provided the repair or re-setting cost can be kept relatively low.

The lower outputs seen with the sensor legform show that it is very important that any trigger system be tested with a test device that is appropriate for the sensor technology used. It is also clear that the trigger should be tested over a wide range of pedestrian statures and accident situations although this has not been explored in any detail here. Because of the need to develop suitable test devices in response to the sensor technology used, it is not thought possible to produce a suitable regulation to cover this issue. Instead a more general protocol could be produced and followed, with the results for each trigger system independently assessed. The sensor legform reported here is thought to be a good starting point for developing an impactor for a bumper contact switch / force type sensor system, however, it would need far more development before it could be used to approve such a trigger system.

Obviously a trigger system that fails to detect a pedestrian accident will result in the protection system not being effective. The tests reported above show that it is important to use an appropriate trigger test tool. It is also clear that any malfunction in the chain of components, connectors, etc. from the bumper face to the pop-up bonnet, could result in a failure to deploy or a deployment that takes too long. Therefore, the whole system must be very reliable over the whole life of the vehicle. System reliability is discussed in Section 6.

5.2.2 Examination and testing of the deployment mechanism

A first tier supplier supplied to TRL a mule vehicle fitted with a prototype pop-up bonnet system, to allow TRL to evaluate the deployment mechanism and its reliability. Five deployment tests were carried out at TRL.

The results for the five tests are shown below, in Table 5.3. There were three types of test carried out with the deploying system. Two tests were carried out with the lifters in the hinge, two more with the lifters under the bonnet reinforcement and one test with only one lifter under the bonnet reinforcement. A fully developed system for a rear-hinged bonnet would have the lifters in the hinge system, but with these prototype parts it was useful to test the lifter without restriction by the hinge. Each test was recorded on high-speed video and the approximate lift times were found by counting the frames from trigger to the bonnet being fully lifted.

Table 5.3 shows the lift time and the peak displacements for three different lift scenarios. The tests under the hinges do not reach 120 mm due to the hinges only having a total travel of around 110 mm. The hinges had a release system which when locked allowed the bonnet to open in the normal way but when released allowed the bonnet to pop-up. The hinges were still in the prototype stage but the release mechanism for the hinge was found to perform well and proved that the concept works.

Table 5.3. Lift times and peak displacements in pop-up deployment tests of bonnet

Test	Time to 120 mm displacement #			Peak displacement			Comments
	LH rear (ms)	CL rear (ms)	RH rear (ms)	LH rear (mm)	CL rear (mm)	RH rear (mm)	
ECP 08	25	28	25	111	127	110	Lifters under hinges
ECP 09	25	29	26	110	125	110	Lifters under hinges
ECP 15	28	33	28	123	135	122	Lifters under bonnet
ECP 16	28	32	27	124	136	124	Lifters under bonnet
ECP 17	n/a	n/a	n/a	109	101	102*	One lifter under bonnet (LH)

The maximum displacement for the hinge was approximately 110 mm and it then prevented further lifting, so the time for tests ECP08 and ECP09 are time to 110mm displacement.

* Difficult to measure due to the twisting of the bonnet.

Although only five tests were carried out, two lifters were used for each except the last test making a total of nine actuator firings. No failures to fire or problems during activation were found despite using prototype parts, which gives some indication of reliability.

Overall, it was concluded that the lifter deployed the bonnet as intended on the mule vehicle. However, to work in practice it would need further development and tailoring of the complete vehicle system including the bonnet, hinges and catch. This development would need to be carried out, in collaboration with the vehicle manufacturer, model by model. It is known that this type of collaboration is now taking place but the results are currently confidential.

5.2.3 Impact testing of the deployable system

A series of headform tests were also carried out on the same pop-up bonnet system and mule vehicle as used for the deployment tests. The test matrix was selected to provide information on the potential of the system in both the current phase two headform test and in a revised phase two test. Although the actuator was in the adult test area on the vehicle concerned, it was also tested with the 3.5 kg child headform to see how the system would perform if used in a smaller car where it would be within the child test area. As TRL does not have a 4.5 kg adult headform impactor, the WG17 4.8 kg impactor was used instead with the test velocity reduced to match the energy of a 4.5 kg impactor at 40 km/h.

The tests were split into comparative tests of the pop-up bonnet in the two positions, deployed and closed (not deployed). The results provide comparison levels for the sub-assembly with and without

deployable passive protection. The test buck has no engine, so results in the centre of the bonnet may represent the best case. Table 5.4 shows the test matrix and results.

Test results are also shown in Table 5.4 and clearly show the benefits of the deploying system. If the results for the non-deployed and the deployed tests are compared, the resulting HIC is reduced by over 50 percent by the pop-up bonnet. The tests were concentrated around the lifter as this is seen to be a problem area, however, overall improvement to the performance where there is insufficient clearance over the engine, suspension, wing edge and scuttle can also be expected.

Table 5.4. Test matrix and results for deployable bonnet tests

Test	Position of bonnet	Headform type	Impact point	Impact velocity (m/s)	HIC
ECP11	Not deployed	Adult (4.8 kg at 4.5 kg impact energy)	Above lifter	10.64	1517
ECP05	Not deployed	Child / small adult (3.5 kg)	Centre of bonnet close to WAD 1000	11.04	1164
ECP06	Not deployed	Child / small adult (3.5 kg)	Above Lifter	11.19	2125
ECP14	Deployed	Small child (2.5 kg)	Above lifter	11.06	1576
ECP02	Deployed	Child / small adult (3.5 kg)	Above lifter	11.04	926
ECP10	Deployed	Adult (4.8 kg at 4.5 kg impact energy #)	Above lifter	10.80	449
ECP03	Deployed	Adult (4.8 kg)	Above lifter	10.98	428
ECP04	Deployed	Child / small adult (3.5 kg)	Centre of bonnet close to WAD 1000	11.13	1163

Target velocity 10.7 m/s

Some resultant acceleration time histories are shown in Figures 5.11 and 5.12. In these two tests there was approximately 40 mm more deflection with the 4.8 kg headform compared to that of the 3.5 kg child / small adult headform. The size and mass of the impactor made a difference in the amount of deflection and thereby the HIC value obtained. The worst test with the deployed bonnet was with the 2.5 kg WG17 child headform (HIC 1576).

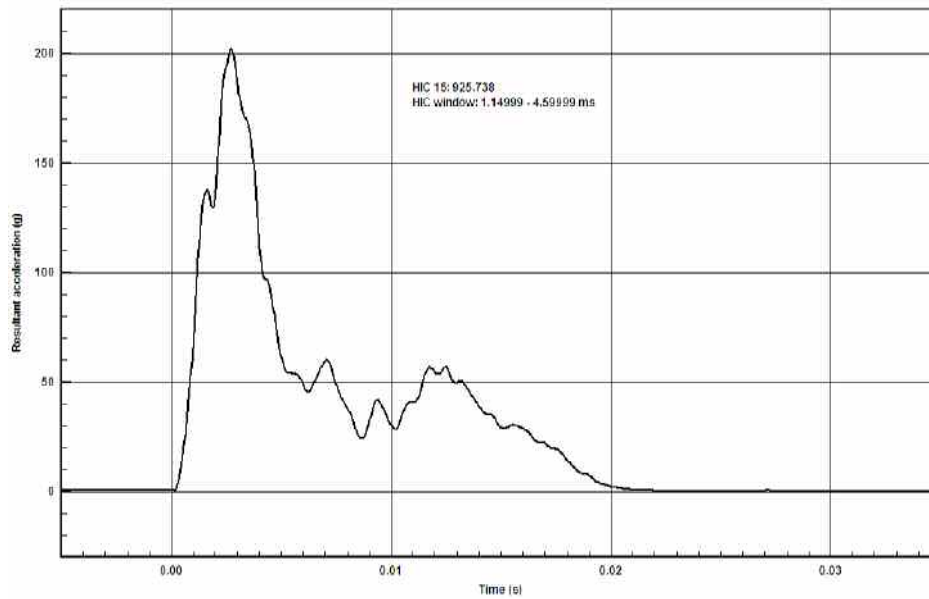

Figure 5.11. Test ECP02 - 3.5 kg child/small adult headform to bonnet above lifter

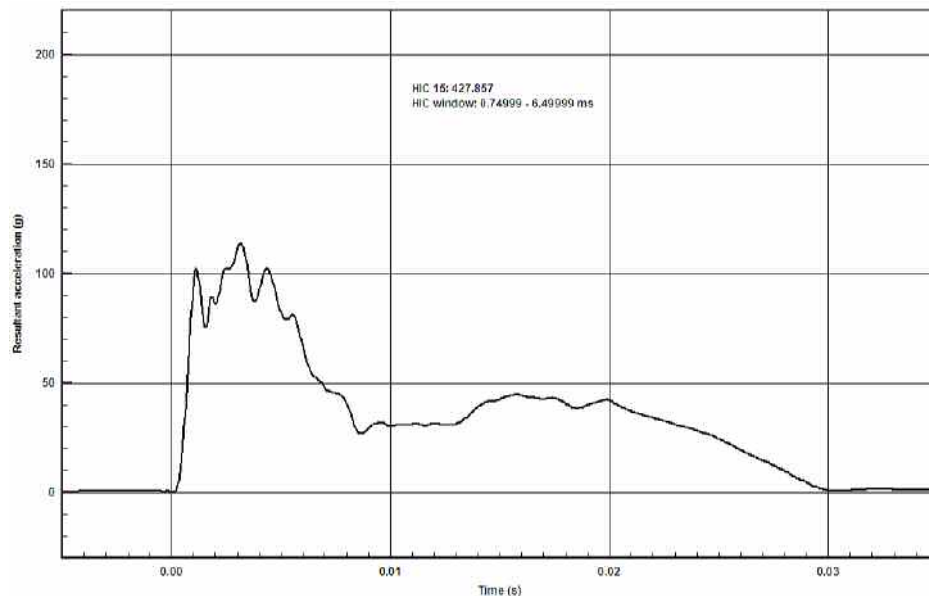

Figure 5.12. Test ECP03 – 4.8 kg adult headform to bonnet above lifter

As the test buck was mounted on a frame with no wheels or suspension, the position for the most forward child headform test at a WAD of 1000 mm had to be estimated from a photograph of a similar car marked up for an Euro NCAP test. It is interesting to note that the point gave almost identical HIC results with the system deployed or not deployed. This may have been due to the fact that the impact point was directly over a reinforcement in the bonnet. Figure 5.13 below is a comparison of the time histories for the two impacts and it clearly shows that the impacts were nearly identical.

In many vehicles HIC values that exceed by a large margin the pass criterion of HIC 1000 are often due to the headform bottoming out on underlying objects. The lifted bonnet allows deformation of the bonnet to occur without the head impacting an underlying structure.

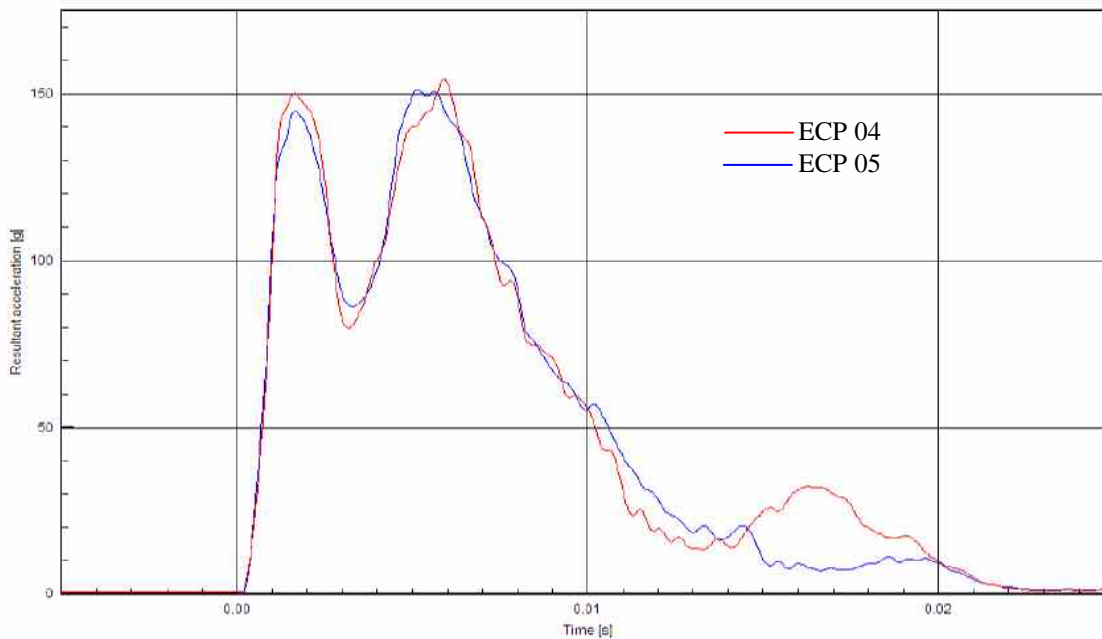

Figure 5.13. Tests ECP04 and ECP05 – 3.5 kg child / small adult headform to bonnet at same WAD distance with the bonnet not deployed and deployed

5.2.4 *The real-life fitness of the deployable device*

For any deployable system it is important that the device deploys as intended. At low speeds the deployable systems should not deploy even if it hits a pedestrian because there would be no significant benefit to the pedestrian in activating the system and the false triggering and repair costs would be unacceptable. In high-speed impacts there would be a risk that the bonnet would be still moving up at head contact, potentially increasing the risk of injury so in this case it again might be better not to deploy the system. However, testing may show that in high-speed impacts it is on balance safer to be hit by a still deploying bonnet rather than by one that has not been deployed, particularly when the bonnet is in the stabilisation phase rather than the main lift phase. Therefore the manufacturer will need to select a range of impact speeds where he wants the system to deploy. Below this speed he will have to build in sufficient crush depth in the non-deployed vehicle that the pedestrian's energy can be safely absorbed by conventional deformation. Therefore, the trigger system will need to be able to detect the impact velocity and determine whether deployment is necessary. In addition to responding to accident speed, both the trigger and the pop-up bonnet system will have to be shown to work safely over a wide range of accident situations including different pedestrian statures, postures and relative motion.

The manufacturer of a pop-up bonnet system under consideration, in addition to considering reliability and suitability of the trigger, has also carried out a combination of tests with pedestrian dummies, both real and by using mathematical simulation. There are a number of concerns for the heads of very tall adults or very small children due to pedestrians of these statures applying only a small force to the bumper in an impact. Further development is still required.

6 Review of reliability of new technologies

When struck by a car, pedestrians risk serious or fatal head injury. Research shows that the bonnet is a major source of these head injuries. This is because there are many stiff engine components beneath the bonnet, but very little space for the bonnet to deform and absorb energy. Traditional pedestrian protection in cars has comprised various means to increase the space beneath the bonnet and absorb some of the energy. However, this approach often leads to a conflict between protecting pedestrians and achieving desirable aerodynamics and styling at the front of the car.

In Section 4, a new approach was introduced, the deployable (pop-up) bonnet. This system provides additional space between the bonnet and the stiff components beneath by raising the rear of the bonnet before contact with the pedestrian's head.

The aim of this section is to provide a review of the reliability to be expected from this new technology. The popular definition of a reliable system is that it works as intended and remains trouble free for a long time. There are many techniques employed by reliability engineers to investigate a system or product. Typically, these techniques require detailed knowledge of the system, including in-service reliability data. In the case of the deployable bonnet system, this information was unavailable and hence to some extent a generic system has been described rather than a specific product. Nevertheless, in order to have a sufficiently detailed description one solution may be described whereas other solutions might use alternative technologies. Whilst any conclusions may therefore be tentative, the review was intended to uncover potential problems with the deployable bonnet.

The approach used to examine the reliability of generic deployable bonnet systems was:

- Define a general description of the system under consideration with a breakdown of the significant assemblies and components.
- Analyse the operation of the system.
- Identify the potential failure modes for the system and complete a fault tree analysis to examine the potential causes of the failure modes.
- Complete a Failure Mode and Effects Analysis (FMEA) using engineering judgement to assign a risk priority number to each potential cause of failure.
- Summarise the potential failure modes and their causes and make recommendations as appropriate.

6.1 System functional description

6.1.1 General system definition

The deployable bonnet system has three main features: a sensor assembly in the front bumper to detect the impact, a processing unit to decide whether to deploy and actuators to lift the bonnet. The bumper sensors feed information about the impacting object into an Electronic Control Unit (ECU), which uses a safety algorithm to decide whether or not to deploy the bonnet. The ECU also receives information from the car's speedometer and from an accelerometer. An overview of the complete system is shown in Figure 6.1.

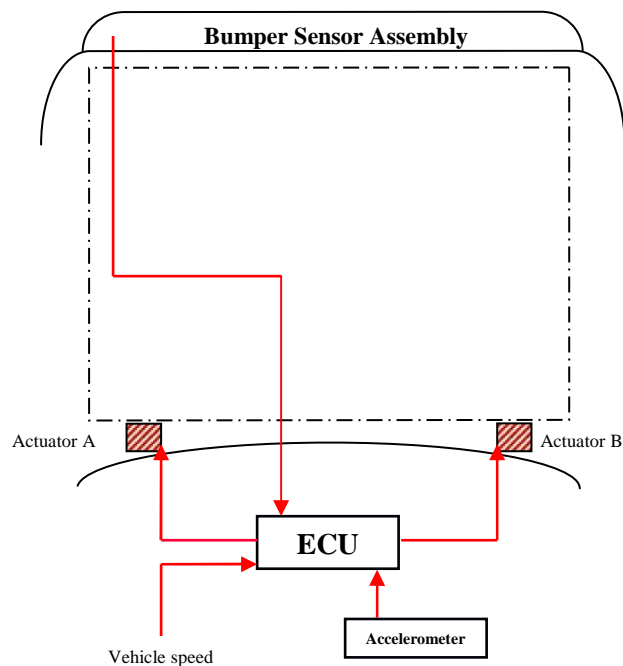

Figure 6.1. Deployable bonnet system overview

6.1.2 Brief component functional description

6.1.2.1 Bumper sensor assembly

The assembly comprises different components. One component is a sensor used to determine the force applied to the bumper. An optional switch-type contact sensor, across the width of the bumper, provides the ECU with the first indication that an impact is taking place as well as the location of this impact. This sensor is divided into elements, each with a number of switches that give a signal when closed. The ECU can use these pieces of information to confirm the impact (reliability) and to adjust the decision according to the impact location.

6.1.2.2 Electronic control unit (ECU)

The main function of the ECU is to control the deployable bonnet actuators but there may also be a performance-monitoring element. The safety algorithm takes data from the bumper sensor assembly, the car's speedometer and from an accelerometer, to decide whether to deploy the actuators. The ECU contains a number of electronic components, but for the purposes of this study it will be considered a single component. The term ECU system fault will be used to characterise the various failures possible within the ECU itself. It is very likely that the ECU will be a wider 'Crash ECU', managing all safety-related features such as air bags, anti-lock brakes, electric power-assisted steering and others.

6.1.2.3 Deployable bonnet actuator

There are two pyrotechnic actuators that raise the rear part of the bonnet in the event of a pedestrian accident. These devices function in a similar way to current pyrotechnic air bag inflators; when the car hits a pedestrian, a propellant is ignited producing a gas as it burns. In the system considered, the gas fills bellows that expand to raise the bonnet in time to provide a crush zone between the bonnet

and the engine block. The bonnet is intended to be deployed before head contact occurs and remain in the raised position. Energy is absorbed by deflection of the bonnet and by deformation of the bellows. The actuators are tuned to resist deformation by upper torso loading in order to absorb maximum energy when head contact occurs. It is recognised that several other methods of raising the bonnet have been developed (see Section 4). However, for simplicity, this part of the study is focused on pyrotechnic bellows only.

6.1.2.4 *Bonnet hinge release mechanism*

The deployable bonnet system calls for dedicated bonnet hinges (in the case of front opening bonnets), which must allow the bonnet to open and close as normal, yet deploy in a pedestrian impact. These dedicated hinges would typically be developed in collaboration with the car manufacturer and may therefore vary from car to car. However, the component is likely to be based on conventional hinges with an extra hinge point that can be released by the action of the actuators and hence allow the bonnet to be raised.

6.1.2.5 *Electrical connection*

This refers to communication between the ECU and the actuators. Sensor cables from sensor to ECU were considered integral to the sensor.

6.2 **Mode of operation**

When the car strikes an object, sensors in the front bumper indicate that an impact has taken place. The operation of the deployable bonnet system can then be characterised by two distinct phases.

The first phase comprises the signal processing within the ECU where a safety algorithm decides whether or not to deploy the bonnet on the basis of a number of sensor inputs. For instance, the speed of the car must fall within a defined range. The low threshold prevents unnecessary deployments where the pedestrian is unlikely to receive serious injury. The high-speed threshold prevents deployments where the bonnet may still be rising when contact occurs. Secondly, the accelerometer measures the car's deceleration and compares it with a deployment threshold. This serves to prevent deployment during impacts with solid objects and other vehicles. Thirdly, the bumper sensor assembly measures the extent of the force applied to the bumper. The ECU uses all these data to determine whether the object hit is a pedestrian. If all the conditions are met, the second phase of the operation begins (i.e. the ECU deploys the bonnet).

In the second phase, the propellant within each actuator is ignited by a signal from the ECU. The gas produced as the propellant burns fills the bellows, which start to expand. The action of the actuators releases a latch within the bonnet hinges and the bonnet is then raised. It is intended that a stable deployment is achieved before contact with the head of the pedestrian occurs.

6.3 **Failure modes**

A potential failure mode describes the way in which a product or process could fail to perform its desired function. In the case of the deployable bonnet system there are two functions. First, it is intended to raise (and hold) the bonnet when the car strikes a pedestrian. Secondly, it must absorb some of the energy from the impact between the pedestrian's head and the bonnet, particularly when the head impact is above or close to the actuator. With these functions in mind, three potential failure modes of the system become apparent immediately:

- Failure to deploy when required (i.e. when the car strikes a pedestrian)
- Failure to absorb energy when deployed
- Deployment when not required

The first of these failures refers to a pedestrian impact in which the bonnet does not deploy, or deploys partially. In these circumstances, it is likely that the pedestrian would receive a more serious head injury, from the stiff engine components beneath the bonnet.

The second failure refers to a situation whereby the bonnet has deployed but it fails to provide adequate protection during the impact between the pedestrian and the car. This failure is also likely to result in a more serious head injury for the pedestrian.

Deployment when not required means that the bonnet has deployed in an impact with something other than a pedestrian, for instance, an animal or a roadside object. This represents a failure of the system to discriminate between a pedestrian and other impacting objects. Deployment when not required could also mean an inadvertent deployment when no impact has taken place. This could occur when the car is parked or, perhaps more seriously, when it is being driven. The repair costs and added inconvenience from an unnecessary deployment are likely to result in customer dissatisfaction. Furthermore, an inadvertent deployment, whilst the car is being driven, might distract the driver to such an extent that an accident is caused. This could lead to injury, with possible legal implications for the manufacturer.

Having identified failure modes (and their effects) for the deployable bonnet system, potential causes of the failures must be found. A cause is the means by which a particular aspect of the design results in a failure mode. The term 'potential' is used to indicate that causes do not automatically result in the failure mode. It is possible to imagine many potential causes for these three failure modes. Good design practice employed in the components of the system should prevent or minimise the frequency of some causes of failure. Nevertheless, it is useful to consider all the potential causes of failure that are possible within a system. A fault tree was therefore constructed to analyse the potential causes of failure for the deployable bonnet system. The fault tree, as shown at the end of Section 6 is in three parts, from Figure 6.2 to Figure 6.5. For each part, the top event is one of the failure modes that are identified above. The objective of the fault tree was to work downward from this undesired top event to determine credible ways in which it could occur, given the operating characteristics and environment of the deployable bonnet system.

The fault tree showed that many of the potential causes of failure were associated with a particular component in the system. These were typically hardware failures or human errors in the design process. The following sections summarise some of the potential causes identified for each of the system components.

6.3.1 Bumper sensor assembly

The potential causes of failure associated with the bumper sensor assembly were erratic sensor performance or a damaged sensor. Erratic performance can have several underlying causes, e.g. Electromagnetic Compatibility (EMC), Electromagnetic Interference (EMI), conditions such as temperature or dirt or a faulty electrical connection. A damaged sensor may be due to vibration, environmental conditions or voltage errors such as over voltage. It should be emphasised that faults in one sensor may not necessarily lead to a failure mode since the decision to deploy is based on a number of conditions that must be met.

6.3.2 Electronic control unit (ECU)

This section refers to the various faults possible within the ECU itself; the effects of external components on the ECU are discussed elsewhere. Faults in the ECU could result in either a failure of the bonnet to deploy when required (i.e. ECU fails to provide an electrical output to the actuators) or an unwanted deployment. The term ECU system fault was used to characterise these potential causes of failure. ECU system faults include ECU component failures, a Single Event Upset (created by radiation or build up of static charge) or a failure due to EMC or EMI.

6.3.3 Deployable bonnet actuator

There are a number of potential causes of failure associated with the bellows used to deploy the bonnet. Three main causes were identified, with a series of underlying causes for each.

- Damage prior to actuation
- Inadequate pyrotechnic output
- Ruptured bellows

The first of these could occur if the location of the actuators is not conducive to routine servicing, if there is a lack of consideration for tamper-proofing, if inadequate or improper mounting has led to damage during its normal life or if there was a lack of consideration for the environmental conditions at the component's location.

Inadequate pyrotechnic output could be a result of an unsuitable material chosen for the pyrotechnic charge, it could occur if the material has been affected by the environmental conditions or if the material has aged during its normal life.

Finally, the bellows might rupture if an unsuitable material was used, if there were flaws in the material, (such as voids which could cause actuation anomalies or failure) or if the material has 'age-hardened' during its normal life.

6.3.4 Bonnet hinge release mechanism

This component is fundamentally mechanical with no electrical interface. A fault would inhibit the operation of the actuators and could therefore result in a failure to deploy (or a partial deployment). The part could be physically damaged or jammed due to corrosion or the influence of an undetected foreign body. Alternatively, poor design specification could result in a mechanism that is too stiff to unlatch when the actuators deploy.

6.3.5 Electrical cable connection

Faults identified for cable connections refer to ECU to actuator connections. Sensor to ECU cables were considered integral to the sensor as a unit. There were several causes of failure associated with electrical cable connections. These were electrical faults such as a faulty termination or a short on a cable; alternatively, there could be a lack of consideration for tamper-proofing, inadequate or improper mounting of a cable that could lead to damage during its normal life or finally, the location of the cable may not be conducive to routine servicing.

6.3.6 Deployment algorithm

An additional category of potential causes of failure were identified by the fault tree analysis. These causes were not associated with a particular component of the system but instead, relate to the safety algorithm that decides whether to deploy the bonnet. The decision is based on a number of conditions that must be met for deployment to occur. These conditions are intended to distinguish a pedestrian from other impacting objects. It is therefore essential that the conditions and any thresholds are appropriate.

There are a wide variety of objects each with different geometry, mass and stiffness. A potential cause of failure is an unexpected accident scenario that the algorithm is unable to detect. An example might be a pedal cyclist, an adult with a pushchair or a traffic cone.

Another potential cause of failure is the use of pedestrian dummies and computer models to tune the deployment conditions and characteristics. Dynamic impact tests of the system will therefore depend on the ability of the dummy to reproduce the interaction between human and car. Since it is not possible to experiment with humans in this way, the behaviour of the pedestrian dummy is typically

compared to a pedestrian mathematical model. While this model may be validated, it may not correspond exactly to a real person.

Finally, crash test dummies represent a standardised human anthropometry (size and shape). It is possible that an unusually proportioned pedestrian may display different kinematics when struck by a car, particularly in the timing and location of the head to bonnet contact.

6.4 Failure mode assessment

Each potential cause of failure was incorporated within a Failure Mode and Effects Analysis (FMEA) for the deployable bonnet system. The potential effects of each failure mode were rated on a scale of one to ten, where ten was the most severe consequence. This rating was called the Severity. The potential causes of failure were rated in terms of the chance of the cause occurring, also on a scale of one to ten, where ten was the greatest likelihood. This rating was called the Occurrence. The ability to detect the cause of failure prior to it occurring was also rated on a scale of one to ten, where ten was the least likely chance of detecting the failure. This rating was called the Detection. The severity, occurrence and detection ratings were multiplied together to obtain a risk priority number. The FMEA for the deployable bonnet system is shown at the end of Section 6 in Figure 6.6.

A subjective analysis based on engineering judgement was used to complete the FMEA. With this approach, potential causes of failure associated with the sensors and ECU achieved a low risk priority number. This reflects the 10 – 15 years experience in the automotive industry with advanced electronic systems, which suggests that their reliability is no worse than other well designed components. Hence the reliability of this aspect of the deployable bonnet is likely to be of the same order as existing systems employed in air bags or anti-lock brakes, assuming that proven design characteristics are used.

Areas of greater risk (as indicated by the risk priority number) concerned the actuators used to raise the bonnet and in the safety algorithm which decides whether to deploy or not. There are two critical aspects of the actuators that must be considered, the bellows and the pyrotechnic material. In the case of the bellows, the material requirements must be specified carefully so as to achieve the deployment profile and avoid failures associated with an inappropriate material. There must also be an evaluation of the manufacturing processes used to form the bellows since it follows that these processes could influence their performance. Equal consideration must be given to the pyrotechnic material, which is burnt to produce the gas needed to expand the bellows. An appropriate material and quantity must be found and it is important that its performance is not influenced greatly over time by the environmental conditions under the bonnet.

Regarding the safety algorithm, a number of potential problems were identified. The ECU ‘decides’ whether to deploy the bonnet based on a number of conditions that must be met. These deployment conditions comprise various sensor inputs concerning the impacting object and the car’s dynamics. Thresholds were set using computer modelling and dynamic impact tests. Clearly, the ability of the ECU to make this decision depends on the validity of the deployment conditions and thresholds. Since it is not possible to test the deployable bonnet system on real people, the reliability of the system therefore depends on the biofidelity of pedestrian dummies. It is therefore important that the manufacturers of the system have an understanding of the relationship between a dummy and a real person.

In any FMEA, the risk priority number is used to identify those potential causes of failure that require most attention. In a typical automotive FMEA, engineers may apply an acceptable limit to the risk priority number. For instance, one manufacturer reports that the number should be no greater than 100. With this in mind, the deployable bonnet system FMEA highlighted a number of areas of potential concern. However, it was not the intention to imply that the system displays potentially unacceptable reliability. Instead, since the analysis was subjective in nature, some potential causes of failure were given deliberately high occurrence and detection ratings in order to focus attention on them. These were typically components that reflect a new technology or new application of existing technology from the point of view of the manufacturer. It seems likely that manufacturers of the

deployable bonnet system have had similar areas of concern and have already taken preventative or corrective action to ensure that the fully developed system will have acceptable reliability.

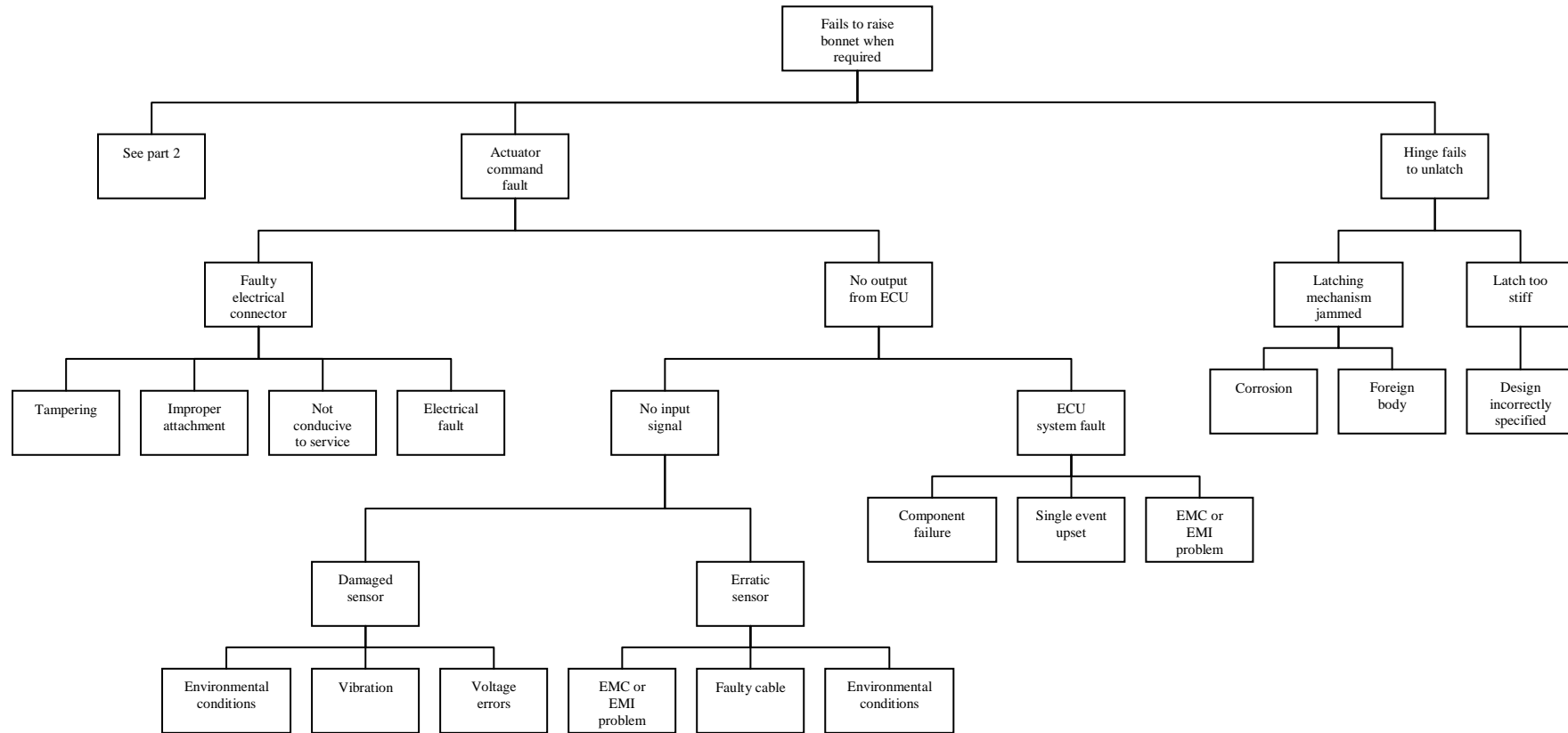

Figure 6.2. Fails to raise bonnet when required fault tree – part 1

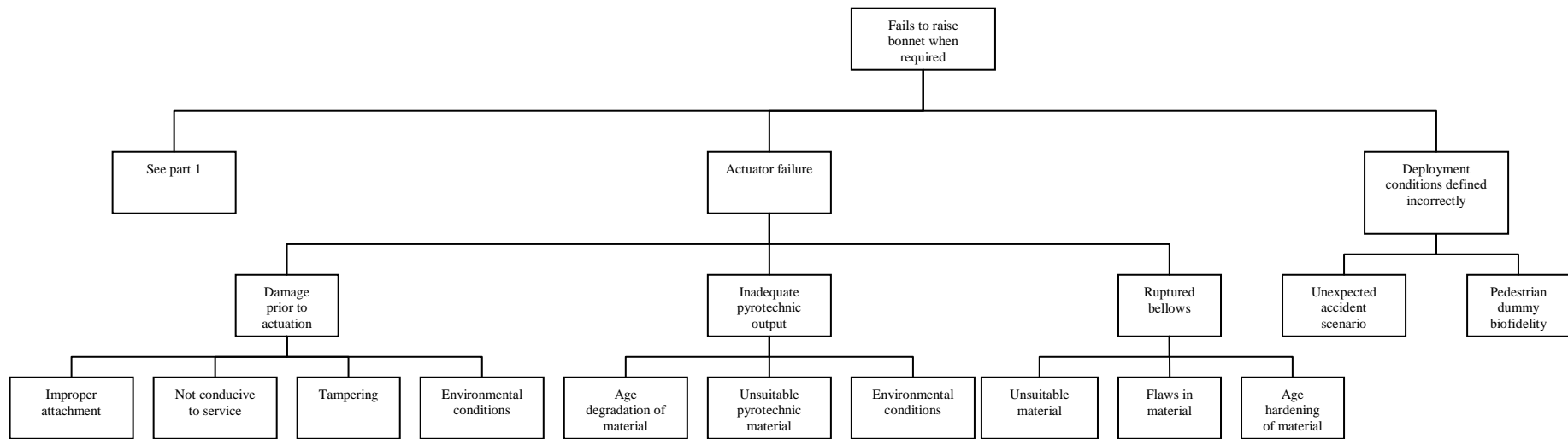

Figure 6.3. Fails to raise bonnet when required fault tree – part 2

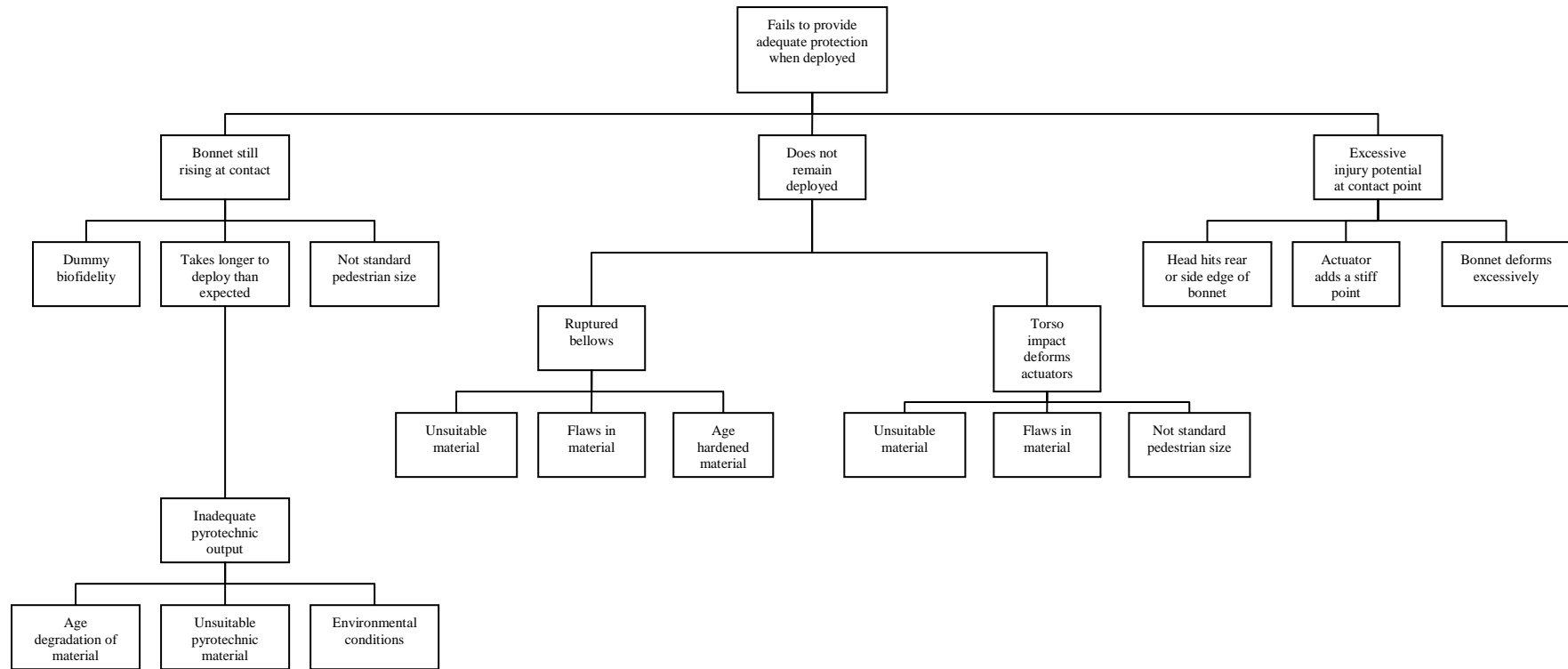

Figure 6.4. Fails to provide adequate protection when deployed fault tree

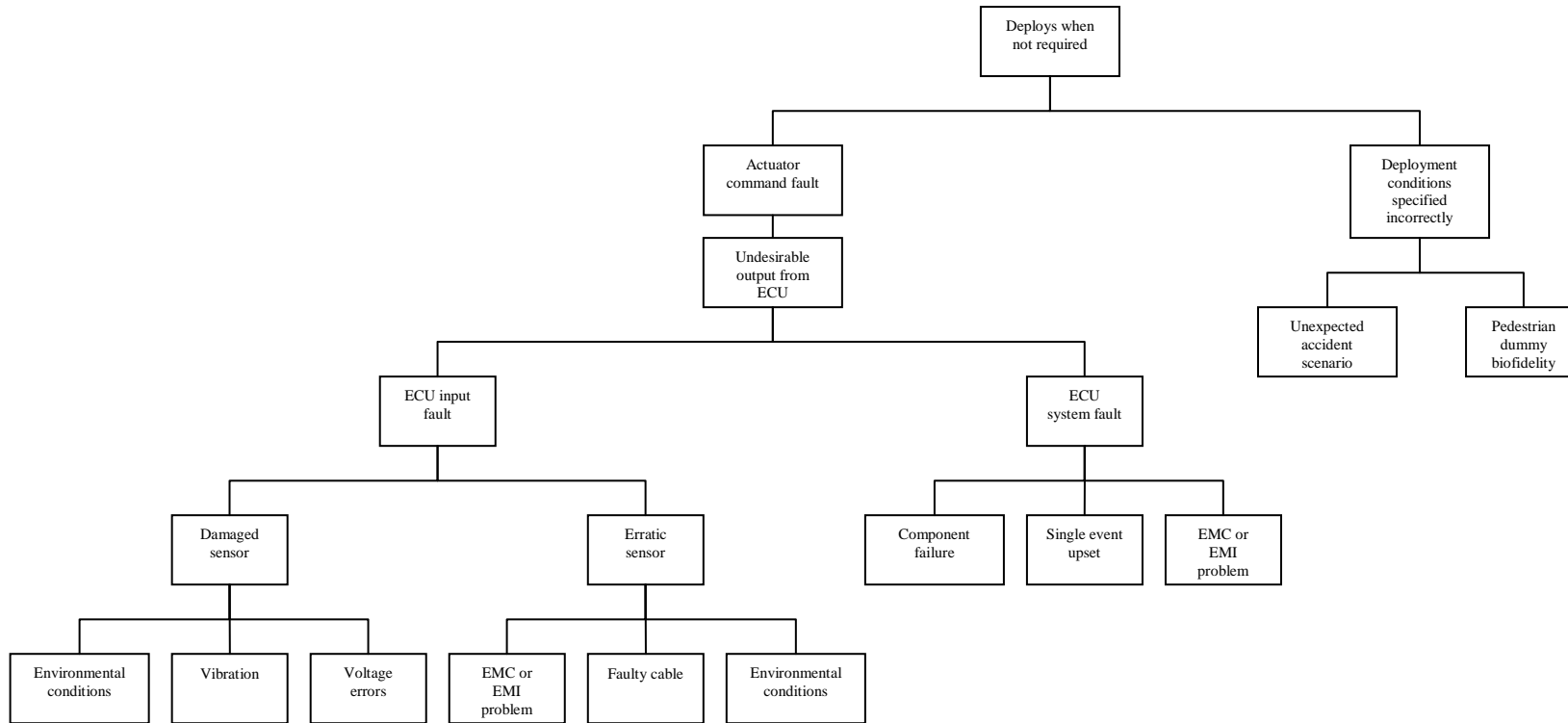

Figure 6.5. Deploys when not required fault tree

Potential Failure Mode	Potential Effect of Failure	Severity	Potential Cause of Failure	Occurrence	Detection	RPN
Fails to raise bonnet	Increases injury severity to pedestrian	10	Damaged sensor			
			Due to environmental conditions	1	1	10
			Due to vibration	1	1	10
			Due to voltage errors	2	1	20
			Erratic sensor			
			Due EMC or EMI problem	2	1	20
			Due to environmental conditions	1	1	10
			Due to faulty cable	2	1	20
			Loose or faulty electrical connection			
			Due to tampering	2	1	20
			Due to improper or inadequate attachment	2	1	20
			Due to location not conducive to routine servicing	2	1	20
			Due to electrical fault	1	1	10
			ECU system fault			
			Due to component failure	1	1	10
			Due to single event upset	1	1	10
			Due to EMC or EMI problem	2	1	20
			Ruptured bellows			
			Due to inappropriate material selection	8	5	400
			Due to flaws in material	6	5	300
			Due to age hardening of material	4	6	240
			Inadequate pyrotechnic output			
			Due to unsuitable propellant selection	3	2	60
			Due to propellant affected by environmental conditions	2	3	60
			Due to age degradation of propellant	2	3	60
			Actuator damage prior to deployment			
			Due to location not conducive to routine servicing	2	1	20
			Due to improper or inadequate attachment	2	2	40
			Due to tampering	2	2	40
			Due to environmental conditions	1	3	30
Hinge latching mechanism is jammed or damaged						
Due to corrosion	3	2	60			
Due to foreign body	1	3	30			
Due to inadequate design specification	2	2	40			
Deployment conditions incorrectly defined						
Due to unexpected accident scenario	3	4	120			
Due to poor pedestrian dummy biofidelity	6	5	300			
Fails to provide adequate protection when deployed	Increases injury severity to pedestrian	10	Ruptured bellows			
			Due to inappropriate material selection	8	5	400
			Due to flaws in material	6	5	300
			Due to age hardening of material	4	6	240
			Torso impact deforms actuators			
			Due to unsuitable material	8	5	400
			Due to flaws in material	6	5	300
			Due to unexpected pedestrian size	7	4	280
			Excessive injury potential at contact point			
			Pedestrian's head hits rear or side edge of the bonnet	4	5	200
			Actuator is a stiff point (i.e. if poorly designed)	2	2	40
			Due to excessive bonnet deformation	2	2	40
			Bonnet still rising at contact			
			Due to poor pedestrian dummy biofidelity	6	5	300
			Due to unexpected pedestrian size	4	5	200
			Inadequate pyrotechnic output			
			Due to unsuitable propellant selection	3	2	60
			Due to propellant affected by environmental conditions	2	3	60
Due to age degradation of propellant	2	3	60			
Deploys when not required	Dissatisfied customer	8	Damaged sensor			
			Due to environmental conditions	1	1	8
			Due to vibration	1	1	8
			Due to voltage errors	2	1	16
			Erratic sensor			
			Due EMC or EMI problem	2	1	16
			Due to environmental conditions	1	1	8
			Due to faulty cable	2	1	16
			ECU system fault			
			Due to component failure	1	1	8
			Due to single event upset	1	1	8
			Due to EMC or EMI problem	2	1	16
			Deployment conditions incorrectly defined			
			Due to unexpected accident scenario	3	4	96
			Due to poor pedestrian dummy biofidelity	6	5	240

Figure 6.6. Deployable bonnet system FMEA

7 Review of technical restrictions

7.1 Input from vehicle manufacturers

To gain a greater understanding of the current stage of research and development with respect to providing protection for pedestrians and meeting the requirements of phase two of the EC Directive, as described in Section 2, European vehicle manufacturers and first tier suppliers were asked for information. Following these requests, TRL Limited was invited to attend meetings with nine European car manufacturers or manufacturing groups and one first tier supplier. A representative from TRL Limited attended meetings with these car manufacturers and first tier supplier.

At these meetings the TRL representatives gave an outline of their approach to this EC feasibility study and an outline of the type of changes to phase two of the EC Directive that TRL might propose to improve the test methods or to take account of feasibility issues, as this was the main topic of the discussions. All of the vehicle manufacturers visited explained that they were concentrating their main research and development efforts on meeting phase one of the EC Directive. For phase two of the Directive, most had just produced a list where they felt that pedestrian protection restricted or conflicted with vehicle functionality or regulatory requirements. Some also had examples where they had modified existing or new vehicles, using a combination of tests to physical prototype vehicles and mathematical simulations of the vehicle and test tools. It was clear from the discussion that in many cases these restrictions or conflicts could be completely or partially overcome by making changes to the vehicle design. However, these changes would have a number of implications to the vehicle's appearance, functionality, etc. All of the manufacturers made statements to the effect that various aspects of the requirements of phase two of the EC Directive were not feasible. They all agreed that the type of changes to phase two of the Directive, that TRL had outlined, would reduce the perceived conflicts but none provided data in the meetings that could be used to determine the extent of these restrictions or conflicts or to help set new feasible protection requirements for phase two of the EC Directive. At each meeting the TRL representative asked manufacturers to provide additional data that could be used to set achievable phase two requirements but only one manufacturer has supplied data to assist with this. The main restrictions or conflicts with the requirements of phase two of the EC Directive given by the manufacturers are presented and discussed in the following sections.

7.2 Design conflicts

The design of a vehicle has to meet a number of styling and functionality requirements in order to obtain customer satisfaction (sales). It must also comply with a number of legislative requirements (safety, emissions etc) to obtain vehicle type approval, so that it can be sold.

As discussed in Section 2, the pedestrian test methods and performance criteria can be simply expressed as a requirement for the vehicle to provide a minimum crush depth and to generate a force whilst crushing that must not exceed a specified level. Although not dictating the overall design of vehicles these requirements overlap with a number of other important vehicle requirements such as occupant crash protection, vehicle structural rigidity, driver view, packaging of components (including all engine variants), styling and low speed damage protection or limitation. These overlapping requirements are presented and discussed in the following sections.

7.2.1 Damageability tests

7.2.1.1 Insurance crash tests

The procedure for conducting low speed, offset crash tests to determine the damage and necessary repairs to a motor vehicle after such impacts, is published by the RCAR (Research Council for Automobile Repairs, 1999). These standard insurance tests are intended to reflect typical low-speed impacts and provide the typical level of damage that insurers are experiencing and paying for every

day; these tests are now used by the RCAR members. The procedure consists of two tests, one for the front where the car is driven at a speed of 15 km/h into a fixed barrier with a protruding facing unit that overlaps the vehicle front by 40 percent. The second test, to the rear bumper, uses a similar protruding face attached to a movable trolley, which is propelled into the back of the stationary car, again at 15 km/h. This test procedure or variations of it are being used to assess the damageability and repair costs of vehicles to obtain insurance ratings. RCAR has also produced design guidelines to optimise the performance of private cars, car derived vans and people carriers of the monocoque design (Research Council for Automobile Repairs, 1995). The advice given in the design guidance covers many aspects of the vehicle structure, some of which may conflict with design issues necessary for compliance with the EC pedestrian protection Directive.

The RCAR design advice suggests the incorporation of crush tubes or crash boxes at the bumper mounting points, or the provision of the bumpers with a stroking capability for energy absorption and instant recovery. Provided that these energy-absorbing measures are behind a load-spreading device such as the bumper beam, they will not constitute local high loading areas dangerous to pedestrians. In some cases crush tubes are currently positioned in front of the bumper beam and any dangerous examples are likely to fail the pedestrian legform test. However, in most cases moving them behind the bumper beam would not be a problem and this solution is frequently seen in newer designs because it is also likely to give more real-life vehicle damage protection. Such energy absorbing systems behind the bumper beam could potentially be used to provide pedestrian protection. However, in practice, because the kinetic energy to be absorbed in the insurance test is so large, the stiffness of the crumple system will be too great for the pedestrian test to initiate crumpling. Therefore, any pedestrian protection will have to be added in front of the bumper beam.

Where it is not possible to alternate the positioning of the tow hook in accordance with the steering configuration, the RCAR guidance is that the tow hooks should be designed so that they collapse downwards and if necessary, break off under 15 km/h impact conditions. An alternative suggestion that is likely to be of greater benefit to pedestrians for tow hooks is where the towing eye or hook forms part of the vehicle tool kit and is not actually mounted on the vehicle until required.

These insurance tests produce some measure of a vehicle's damageability and they are often followed by a repair study that assesses the repair costs in terms of parts and labour. These damageability results and repair costs are then used to help set an insurance rating for the vehicle model. As they focus on overall costs the same rating can be achieved with low damageability and high repair costs or with higher damageability and low repair cost solutions. In Europe, the approach tends to be to balance these two factors whereas in North America and Canada the emphasis is more on minimising damageability, as required by their legislation (see Section 7.2.1.2). As a low insurance rating is an advantage in selling cars, manufacturers strive to keep damage and repair costs low. Both good damageability and pedestrian protection require impact energy to be absorbed in a controlled manner, therefore the addition of pedestrian protection could have some affect on a car's insurance rating. If pedestrian energy absorbing systems are added on top of the current damage mitigation systems then they may reduce damageability and insurance costs to some degree (depending upon the damageability and repair cost of the added pedestrian energy absorbing system itself), but if they replace or degrade them then they might add to insurance costs.

7.2.1.2 Bumper legislation

There are three regulations relating to bumper performance: Economic Commission for Europe (ECE) - Regulation 42 (Economic Commission for Europe, 1980), National Highway Traffic Safety Administration (NHTSA) - Code of Federal Regulations 49, Part 581 (NHTSA, 1999), and Canadian Motor Vehicle Safety Regulation (CMVSR) - Standard 215 (Transport Canada, 1978).

Both ECE Regulation 42 and NHTSA Part 581 include a pendulum test of the bumper face and corners (or equivalent) with a velocity of 4 km/h (2.5 mph) for the face and 2.5 km/h (1.5 mph) for the corners, but NHTSA Part 581 also includes 2.5 mph barrier test to the front and rear. In both regulations the pendulum mass must equal that of the car under test and both require that after the

tests the lights must work, the bonnet boot and doors operate in the normal manner and all of the essential features for safe operation of the vehicle must still be serviceable. The Canadian Standard 215 uses the same equipment, test methods and similar limitations on damage as the NHTSA Part 581 regulation, however, all test speeds are double that of the NHTSA requirements. As already noted in Section 7.2.1.1, a good resistance to damage and providing pedestrian protection both require impact energy to be absorbed in a controlled manner. However, large forces are permitted when absorbing the large quantities of energy involved in these regulatory bumper tests (so long as damage is limited), whereas in the pedestrian bumper test there is an effective limit on the force via the legform acceleration criterion. Some matching of these conflicting requirements can be achieved if a combination of flexible bumper facia and energy absorbing foam is used. With this arrangement, comparatively stiff foam would be needed for the legform test due to the small area of contact and this foam would generate a far bigger force in the barrier and pendulum tests because the contact area would then be larger. However, although this might help to match the different stiffness requirements of these two tests, the pedestrian requirement is still likely to be lower, particularly for the Canadian test. Therefore, the pedestrian protection would have to be added on top of the current damage mitigation systems, requiring an increase in crush depth. However, foam introduced between the outer plastic bumper facia and the bumper beam for pedestrian protection would also be effective in providing protection in some car park knock type situations and could reduce damage in minor knocks, particularly if it recovers afterwards.

Clearly the requirements of both tests can be met, if an appropriate compromise is found between bumper stiffness and crush depth, but overall a larger crush depth will be needed to pass both tests than the minimum needed just to meet the Canadian 5 mph test. This additional crush depth can only be found by some combination of lengthening the car, or moving back or making thinner underlying hard structural members such as the bumper cross member and the ends of the chassis rails; changes such as this have other implications.

7.2.2 Occupant protection crash tests

The EC Directive 96/79/EC (European Parliament and Council of the European Union, 1997), pertaining to the frontal impact of motor vehicles, specifies a test in which the vehicle to be tested impacts a barrier with a deformable front face (of comparable stiffness to the front of another car) at 56 km/h, with 40 percent of the vehicle front overlapping with the barrier. To pass, the vehicle must protect the occupants, in this case as represented by a Hybrid III dummy in each of the front seats, against injurious interactions with the vehicle structure. Other criteria are concerned with the ability of the occupants to escape after an impact, for example, that it must be possible to open at least one door following the test. The level of protection necessary to fulfil these requirements demands that the occupant compartment of the vehicle remains suitably intact. This in turn implies that the structure of the vehicle in front of the occupant space absorbs a sufficient proportion of the impact energy. To achieve this, vehicle manufacturers direct the impact force towards the chassis of the vehicle and tailor the collapse of the 'rigid' elements of the chassis to limit the forces on the occupant. Also the packaging arrangement is designed to maximise the available crush depth forward of the occupant compartment. This design ambition manifests itself by bringing the main chassis longitudinal rails, or some replaceable, deformable element thereof, as far forward in the vehicle as is possible. This is combined with strong cross-members linking the chassis rails and the upper longitudinal load paths e.g. bumper cross-beam and upper cross-member (the bonnet latch and upper cooling pack support). These cross-members not only provide a link to absorb energy in the offset frontal crash test but also provide torsional rigidity for good handling and a distributed contact path for improved compatibility.

Because of the high energies involved in frontal impacts, the stiffness of the structures provided to absorb this energy is far higher than that required when hitting the legs of a human. Therefore any pedestrian protection at the bumper and bonnet leading edge must be added in front or on top of these structures.

7.2.3 *Other vehicle requirements*

7.2.3.1 *Ramp angle*

Obviously, in use, vehicles need to be able to contend with abrupt changes in road gradient and to be able to override small steps such as kerb edges and speed control ramps. Therefore, each manufacturer is likely to have a series of internal design standards for this depending on the type and use of the vehicle model. This is expressed as the vehicle's ramp angle and is the angle between the front wheel contact patch and whichever part forward of this gives the smallest angle to the horizontal. These internal standards are likely to be slightly different between manufacturers but it is thought that a typical value for a normal passenger car would be about 14.5° to non-structural elements such as a rubber apron on the spoiler and about 16° to structural elements such a steel beam behind the spoiler. The angles for sports cars, which often have less ground clearance and a longer overhang, will be lower than these, but will be accepted by owners who are likely to expect a vehicle of this type to have a lower ramp angle. Likewise the angles for off-road vehicles should be greater than those for saloon cars.

As identified in Section 2, one solution to reducing the knee bending angle is to provide a deeper and more vertical bumper front face and one option for achieving this is to move the spoiler forwards (moving it downwards would also help).

However, if one makes the assumption that current design principles are related to the actual use of vehicles and not just the intended use (which is most likely to be the case for saloons and sports cars), then the scope for changes is small.

The only other options to achieve both the desired more vertical front face for pedestrian protection and the required minimum ramp angle are to move the bumper face rearwards and the front wheels forwards. However, again the scope to make such changes is limited by packaging and functional requirements.

7.2.3.2 *Cooling requirements*

If the spoiler / bumper lower edge is moved forward to improve pedestrian protection then it will normally be necessary to raise it as well in order to maintain the current minimum ramp angle for the vehicle type concerned. By bringing the lower edge of the spoiler / bumper up, the available surface for controlling airflow is reduced. In many cars, this surface is critical for providing airflow onto the cooling system of the vehicle, passing air through the radiator, or radiator and air conditioning condenser. Any reduction of airflow to cool the engine due to a smaller air intake area could result in engine overheating in some current designs, particularly when providing a high level of power for sustained periods (towing and hill climbing). Therefore, for some vehicles where cooling is already difficult, extra measures will be needed. This could take the form of more powerful cooling fan(s), more efficient radiators or more efficient ducting. However, this is likely to occupy a greater volume than current fans and therefore add to packaging conflicts. Ultimately airflow requirements for cooling might restrict the adjustments in spoiler / bumper shape that can be made to provide pedestrian protection.

7.2.3.3 *Headlamps*

Headlamps are normally positioned within the bonnet leading edge test area and depending on styling are either tested directly on the lens or indirectly by being positioned beneath the bonnet leading edge. One option would be to move the main lamp units away from the bonnet leading edge; however, lighting regulations specify a minimum height for headlamps so for most saloon cars the scope to move them is limited. A second option is to provide the necessary energy absorbing capacity in the headlamp, either by making the headlamp lens and reflector box collapsible or by allowing the whole headlamp unit to move bodily into the vehicle when hit. Making the headlamp unit deformable is thought to be the most practical method and this was used on the Honda Civic, which came close to

meeting the upper legform requirement, giving a maximum bending moment of 333 Nm and a force of 5.51 kN (Lawrence *et al.*, 2002). This can be compared against the current phase two limits of 300 Nm and 5 kN respectively. The second method of absorbing energy by allowing the whole headlamp unit to move bodily can only be used with low weight headlamps but it does require room for it to collapse into and mountings that are vibration free in normal use but that collapse on impact. However, heavier headlamps would require weaker collapsible mountings and modern headlamps are becoming increasingly heavy. The complete headlamp unit must house the lens, bulbs, reflectors, bulb fittings (and electrical power units for high light intensity outputs) and in some cases motors for vertical height (zenith angle) adjustment and in the future, lateral (azimuthal) beam adjustment. Therefore modern headlights can have a mass in the region of 3 kg. It has been shown that an upper legform test into an un-mounted 3 kg headlamp unit produces an impact force of approximately 2.5 kN due to just the inertial forces of accelerating the headlamp, which suggests that absorbing energy by collapsible mounts may be difficult or impractical for heavy headlights. However, the features that make some modern headlights heavy are to improve illumination, which at night should help drivers to avoid some pedestrian accidents. Modern headlamps are large expensive items and look set to become more so with the introduction of directional beams. Therefore a conflict is perhaps inevitable between improved illumination and pedestrian impact protection considerations which, as discussed above, is likely to be provided by deformable or frangible headlamp and / or mounting. This could result in high replacement costs but this may be resolved through designing them so that instead of having to replace the complete unit, it is only required to replace the low-cost parts that are designed to fail on impact.

7.2.3.4 Bonnet leading edge

The car manufacturers visited provided little data on the feasibility of meeting the bonnet leading edge test. Some assumed or predicted a low efficiency in absorbing energy, others higher efficiencies. Many overlaid the required deformation over cross-sectional drawings of current or modified vehicles and concluded the test to be infeasible because they overlapped stiff points such as the upper cross-member and cooling pack. Most pointed to the poor current performance in Euro NCAP tests and the low incidence of femur and pelvis fracture to say that the test was incorrect and unnecessary. This was discussed in Section 3.

Conventional bonnet latches provide an area of localised stiffness at the front of the bonnet. As such they create an area for both upper legform and also, for some vehicles, for the child headform tests. To resolve this, latches with deformable elements or the ability to sink into the locking platform, in association with deformable bonnet stops or spring mounted stops, will be needed to meet phase two of the Directive when meeting the upper legform performance criteria becomes mandatory. It has been suggested by one manufacturer that the requirements of phase two imply a bonnet latch, and front of bonnet in general, that will be susceptible to plastic deformations just through closing the bonnet. Other problems associated with the necessary weakening of the latch and surrounding area are that in a frontal crash it would result in higher forces at the hinges, which may tear off. This would mean that the bonnet makes less contribution in an accident and might be pushed through the windscreen. With a very weak latch, deformations may occur in the manufacturing process. There is also a performance requirement for the latch to be durable for the lifetime of the vehicle. The combination of all these factors creates an issue for the feasibility of meeting the EC Directive phase two requirements for the front of the bonnet and in particular the latch area.

Whilst research and current good vehicles indicate that the current bonnet leading edge test requirements of phase two of the Directive is feasible for vehicle shapes that attract a low severity test, the current requirements are thought to be unfeasible for many taller vehicle shapes. Updated test energies have been proposed in Section 3.3.3.3 and these may extend the number of feasible vehicle shapes. However, the current energy cap set at 700 joules is likely to need to be reduced to make the test feasible for most vehicle shapes.

The current upper legform energy cap was introduced by EEVC WG17 on the grounds of feasibility based on their decision that 150 mm of crush was the maximum crush depth that it was feasible to

provide. This calculation included allowances for a number of factors including, efficiency with which the vehicle absorbs energy by deforming, corrections for the impactor mass in front of the load transducers which mean that the force on the vehicle can be slightly higher than the force criterion and an allowance for the energy absorbed by the impactor's foam flesh. However, it did not include a correction for the manufacturer's allowance for approval and conformity of production, discussed below in Section 7.2.5. All of the manufacturers visited who made vehicle shapes that attract significant test energies thought that it would not be practical to provide the necessary crush depth to absorb 700 J particularly when they added their allowance. One manufacturer provided simulation data for a large saloon car where they had revised the design to try to meet the phase two requirements; the results showed that it could absorb the required test energy of 600 J with a force of 6 kN (phase two maximum is 5 kN) in a crush depth of 122 mm, however, the modifications necessary were not thought to meet functionality requirements for bonnet edge flutter or safety hook requirements. Examination of the simulation results shows that the energy absorbing efficiency of the bonnet leading edge structure was only about 50 percent; therefore had it been optimised to absorb energy more efficiently (manufacturers often claim efficiencies of 60 to 70 percent), then it is reasonable to assume that it could have been made to pass. Nevertheless, lower efficiencies are more likely for complex areas such as the bonnet leading edge where components serve a number of functions and where a number of different structures and components meet. Based on this one result and considerations of the practical minimum crush depths needed to absorb energy it is thought that an energy cap of 500 J would make this test feasible.

A further concern raised by one manufacturer was for one box vehicles where the front face and windscreen are essentially flat and the front occupants are positioned very close to the front of the vehicle. Depending on their size, the windscreen base of these vehicles could be involved in the upper legform test or be part of the child headform test area. For this type of vehicle, providing occupant protection and structural integrity of the passenger cell is very difficult and it is thought that there will be some incompatibility between occupant and pedestrian protection. There appears to be two options to resolve this. One is to exempt some parts of this type of vehicle from pedestrian tests. In this case it is recommended that this be done on a vehicle model by vehicle model basis, depending on where the occupant protection features conflict with pedestrian ones. It is noted however that this might be difficult to manage within a Directive type regulation. Alternatively the manufacturers can restyle the vehicle by adding a short energy-absorbing nose that would both provide pedestrian protection and add to the occupant protection. Although it is acknowledged that this second option would effectively outlaw one current vehicle style, it is not thought that adding a nose would have any serious implications on vehicle requirements (functionality or regulatory). Of these two options the second appears to be, on balance, the better idea and it is recommended. If this recommendation is accepted then there is no need to change the pedestrian test methods for one box vehicles in the second phase of the Directive.

7.2.3.5 *Wing stability*

To reduce the severity of a head impact to a wing edge, it is important to provide the correct stiffness and crush depths. The wing edge is normally attached to an extension of the inner wing or to the upper longitudinal reinforcing load member. Currently the wing edge and joint often form a rigid box-like shape and for some vehicles there is insufficient space to absorb the headform energy between the wing edge and the strong underlying upper longitudinal load member. In many cases minor adjustments to the design can release sufficient clearance. However, current wing edges are designed to accommodate external forces such as a person pushing on the wing or sitting or leaning on it. In addition, the rear edge of the wing must be well supported to prevent it intruding into the door opening area in minor accidents. These requirements conflict with the low stiffness requirements for a child headform with a mass of 2.5 kg.

7.2.3.6 Bonnet

As for the wing edge, manufacturers are concerned that the low mass of the 2.5 kg child headform impactor, used in phase two of the EC Directive, will require the bonnet stiffness to be very low which would make it vulnerable to damage.

Other requirements of the bonnet are that it must be torsionally stiff enough not to plastically deform when opened from one side rather than from the middle. The bonnet must also be rigid enough to prevent fluttering at high speeds due to aerodynamics and wind forces. Both of these requirements of the bonnet may be tested in sub-system tests by the manufacturers and have been shown to provide practical limits for how deformable the bonnet can be.

For large vehicles such as Sports Utility Vehicles and off road vehicles, the height of the bonnet leading edge may be close to a Wrap Around Distance (WAD) of 1000 mm. Therefore the child headform test zone would start only one headform radius back from the bonnet leading edge reference line, whereas in normal saloon cars there is a larger gap between the bonnet leading edge reference line and the start of the child zone. Therefore for these large vehicles, the child headform test may impinge on body features such as the headlamp mounting and the bonnet lock and underlying upper cross-members. It has been suggested by one manufacturer that for SUVs, it is not feasible to design enough reduction of stiffness into the area around the headlamps to meet the HPC < 1000 limit for the 2.5 kg headform, even at a reduced impact speed of 30 km/h.

Therefore, there may be some conflict between a bonnet that is soft enough and has adequate crush depth below, with the functional requirements of a bonnet that can be opened and closed without damage and not flutter at high speed, and the necessary underlying components such as the headlamps and upper cross-member.

7.2.3.7 Windscreen scuttle

To protect the head of a pedestrian from making a hard contact with a windscreen wiper spindle, the spindles should be located in a position shielded from impact by the rear edge of the bonnet and at a depth below the bonnet for appropriate energy attenuation before impact. When impacted by the headform directly or indirectly the wiper spindles need to be capable of deforming or moving down. However, to function in rain, to resist wind loads at high speed, to withstand freezing-on and snow loads, requires strong and rigid mountings. This conflicts with the need for it to deform for pedestrian protection. One approach to overcome this conflict is the use of rigid but frangible wiper mountings. This method is used on the Honda Civic and failed as intended when tested in the Euro NCAP test with an adult headform. However, as reported by Lawrence *et al.* (2002), only one of the two frangible mountings failed in a 2.5 kg child headform test, giving a HIC of 1539. Two other hard spots are often found in the scuttle areas. The first is where an air-intake chamber for the vehicle interior is formed, typically between the base of the windscreen and the engine bay, by extending up the engine bay bulkhead (firewall). This extension typically makes a hard point at the rear of the bonnet because it is used to support the bonnet and to seal the engine bay. However, in prototype vehicles this extension was being replaced with a deformable plastic trough. The second point is the base of the windscreen, which as well as supporting the windscreen also provides a further cross-member to improve structural integrity. However, a solution for this area has already been found in the Honda Civic where a 'C' sectioned member is used to provide the necessary structural properties and there is also a cantilevered windscreen support, which can deform under head impact.

Feasibility may be particularly difficult for vehicles with bonnets of such a length that nearly all of the bonnet top test area is within the child zone but where small adult areas exist at the base of the windscreen. Therefore it is proposed for these vehicles that the adult zone can be tested, point by point, with either the child headform or the adult headform, based on the manufacturer's specified child and adult areas within a specified optional child / adult zone. Accident data considered by IHRA suggests that head contact for larger children can be up to a wrap around distance of 1700 mm. Therefore it is recommended that an optional child or adult test zone be permitted between 1500 mm and 1700 mm wrap around distances. However, as this relaxation is only intended for vehicles with a

small adult test area it is recommended that this option be restricted to vehicles where all parts of the bonnet rear reference line are 1700 mm or less.

7.2.4 *Cosmetics*

Styling and / or aesthetic considerations are very important to the car buyer when deciding which car model to purchase. Therefore, these features are also very important to the car manufacturers, who not only strive to make their cars attractive but also to create a brand style. However, it is difficult to judge the importance of these considerations against providing pedestrian protection. For some vehicle types a compromise may be comparatively easily to find where some room is already available and the style is such that changes for pedestrian protection will have little impact on appearance. However, for some current vehicle types such as sports cars and large executive cars, changes for pedestrian protection might detract from the vehicle's appearance. For example more crush space in the wheel arch area could be released by fitting smaller diameter wheels; however, this would go against the current fashion for this type of vehicle to have large wheels.

To take the upper legform test area as an example, the bonnet leading edge area provides interesting pedestrian protection, packaging and aesthetic conflicts. To look pleasing to a potential car buyer it appears desirable for a saloon type vehicle to have a low bonnet leading edge. This causes the packaging of the engine components to be difficult and there is very little space available in this region. To absorb the energy from an upper legform test, as detailed in the EC Directive, sufficient crush depth is required. If it is not possible to provide this space due to packaging issues then the only options are to make the underlying package items deformable or to change the vehicle shape by raising the bonnet leading edge. This will dramatically change its appearance and the risk is that customers will not like the adjusted image for the type of car they were considering purchasing.

Therefore styling and aesthetics considerations may be in conflict with the pedestrian protection requirements of phase two of the EC Directive.

7.2.5 *Approval and conformity of production*

Modern design methods used to develop new cars make extensive use of computer simulations to show if the design will comply with safety regulations. However, by their nature computer simulations do not give a perfect evaluation of a vehicle's real-life performance. For current regulations this is allowed for by the manufacturer providing a margin of protection above the minimum legislative requirement. These modern design methods combined with engineering judgment and experience mean that manufacturers have a high confidence that their design will pass the current regulatory approval test before a representative physical vehicle is made. Manufacturers are able to take advantage of this confidence by reducing the amount of prototype testing, and save time and investment by committing themselves to producing production tooling, etc. at a comparatively early stage in the vehicle's development. However, it is very likely that pedestrian protection performance will be more difficult to predict accurately because the impact energies are far lower than normally found in vehicle to vehicle or vehicle to roadside object type accidents.

Manufacturing processes are inherently prone to slight variations from one item to the next. This is a problem for vehicle manufacturers because vehicles are made from large numbers of components; small variations in these might influence the overall safety performance of each car made. Also the necessary tolerances on impact velocity, direction, etc. within the pedestrian test methods will also give rise to some further variation in test results. To ensure that the first vehicle used in the approval tests and all of the vehicles subsequently produced will or would be able to meet legal requirements for that vehicle, the manufacturer normally designs the vehicle to be inside the requirements by as much as 20 to 25 percent. This is usually taken to be the acceptable approach when considered against the consequences of exceeding the regulatory requirements of:

- failure to obtain type approval of a new model at a late stage in its development – rectifying this might be very expensive.

- withdrawal of the type approval for the model until necessary improvements have been made if manufacturing variations of vehicles produced after type approval are shown to take some examples outside the regulatory requirements - implying substantial financial losses for the vehicle manufacturer.

One vehicle manufacturer has suggested that a larger margin may be required for the bending angle criterion in the legform test but as can be seen in Section 3, proposals have been made to tighten the tolerances on this test to reduce this variation.

The net effect of the manufacturers' allowance is that the vehicles will be safer than implied by the minimum regulatory test requirement. This would be beneficial as it would result in additional casualty savings. However, where it is difficult to provide the minimum regulatory requirement, the need for this additional margin of safety could make the task even more difficult and thus adversely affect the feasibility of meeting the legislation. In this case the legislative protection requirements could be adjusted so that the protection provided, including the manufacturers' allowance, equates to what is currently required.

7.2.5.1 *Failure to comply and difficult areas*

The problems for vehicle manufacturers to accurately predict the pedestrian protection performance of a vehicle during the design stage are exacerbated by the large test areas on the vehicle, which reflects real-life pedestrian accidents. Therefore, there is a risk that a manufacturer could have nearly completed the development of a new vehicle and made all of the associated investment, before finding that one small and difficult to change area exceeds the performance requirement. This problem is addressed to some extent in the first phase of the EC directive by the use of a manufacturer nominated zone with less protection for the head. Currently the second phase of the EC Directive removes this option, however, unless this principle is included in phase two and extended to all the tests areas, there is a risk that some vehicle designs would need extensive and expensive modifications at a late stage in their development if one small area is found to exceed the performance criteria by a small margin.

There are a number of 'difficult areas' highlighted above such as the wing edge and scuttle for the headform test and it is thought that similar areas are likely to be found for the other tests. For the upper legform test, areas such as the joint between the bonnet and wing and the joint between the cooling pack and headlamps, could prove to be difficult stiff points. Similarly for the bumper, areas around the ends of the chassis rails and towing eyes could prove to be difficult due to excessive stiffness or insufficient crush depth. The proposal for manufacturer nominated zones in the paragraph above, to help prevent late and costly failures in compliance, could also be used to improve feasibility for these difficult areas. To minimise the width or area with less protection it is recommended that these zones should be no more than two impactor widths for the bumper and bonnet leading edge and 25 percent of the bonnet top test area. It is thought that this will provide a reasonable balance between increased injury risk and feasibility requirements.

One manufacturer provided simulated headform test data for the bonnet top, bonnet latch, bonnet to wing edge, wiper spindle and the hinge area. These results suggested that a HIC of 2000 was feasible at an impact speed of 40 km/h using a child / small adult 3.5 kg headform. Their only concern was for the wiper spindle of small vehicles where it would be in the child test area and in this case the simulation results were HIC 2031. However, Lawrence *et al.* (2002) tested the wiper spindle of the Honda Civic at 40 km/h using a 2.5 kg headform and this was shown to give a HIC of only 1539. As the principal problem in these difficult areas is that of excessive stiffness due to functional requirements, then it can be concluded that better results should be possible with the adult headform. In addition as reported in Section 5, Table 5.1, tests of three locations on the wing edge of the Honda Civic at 40 km/h, using a 3.5 kg child headform, gave a worst HIC of 1523. Therefore, overall it appears reasonable to conclude that a HIC of 2000 would make these difficult areas feasible.

7.2.6 *Restrictions due to overlapping test zones*

To provide effective pedestrian protection it is necessary for each contact point on the vehicle to be sufficiently soft to keep the loading on the pedestrian's body part concerned below the injury threshold. By breaking the impact up into discrete phases and concentrating on certain 'most at risk statures', it is possible that dangerous features might be encouraged in the individual sub-system tests. However, if as intended by EEVC, these undesirable features are failed by the next test then they too will have to be made to provide effective protection and a revised solution will have to be found for the first test. Thus in this case the overlapping of test zones will be beneficial. In the second phase of the Directive, the combination of test methods is intended to achieve this effect. However, overlapping of different requirements for different pedestrian statures can in some cases either provide less appropriate protection or areas where one part of the vehicle must pass two different requirements which will generally require larger crush depths.

7.2.6.1 *Legform tests*

In the legform to bumper test, the femur section of the legform impactor often makes a contact with the bonnet leading edge at some stage during the impact. This can be beneficial in reducing the lateral bending angle of the impactor's knee. One manufacturer showed TRL simulation results where the stiffness of the bonnet leading edge had been optimised to achieve the best knee bending angle in the legform test. They concluded that there was a conflict between the legform test and the upper legform test because, for the range of car shapes considered, these results showed that the optimal bonnet leading edge stiffness for the legform test did not always match that required for the upper legform test. However, TRL pointed out that as the femur section of the legform is not intended to control the bonnet leading edge stiffness, then the failure of any overly strong bonnet leading edge in the subsequent upper legform test was in fact the two tests working together as intended.

7.2.6.2 *Upper legform*

The front upper cross-member needs to be comparatively strong because it provides the bonnet mounting for the bonnet lock, the upper fixing for the cooling pack and forms the necessary link between the upper load paths in the inner front wing area. For vehicle shapes that warrant a large upper legform test energy, one option is to move the upper cross-member slightly more rearwards in order to obtain sufficient crush potential in front of it. However, for some vehicles this could result in it being moved into or close to the child headform test zone. In many cases this will mean that the bonnet lock, striker, etc. are behind the main upper legform deformation area. In this case it is thought that by providing sufficient clearance between the bonnet top and the cross-member, and by the use of a collapsible or push through bonnet striker (as described in Section 8), it should be possible to provide protection for the child headform. For vehicles where the bonnet leading edge is on or behind the 1000 mm wrap around line, the Directive already includes a relaxation by moving part of the child headform test zone back one headform radius. Therefore for both vehicle shapes, it is not thought that the potential overlap, which reflects the real-life overlap between children and adults, is insoluble, particularly when the changes to the second phase of the EC Directive proposed in Section 3 and later in Sections 7.4.1.3 and 7.4.1.4 are taken into account.

7.2.6.3 *Headform tests*

In phase two of the EC Directive, the headform test switches from the child test to the adult test at the 1500 mm Wrap Around Line (WAL) between the child and adult test areas. It is obviously almost impossible to have a step change in the stiffness each side of a line, (unless the line falls on a joint in the structure) so it is not practical to have an optimum stiffness for the different headform masses. Therefore the only solution is to bias the stiffness towards the lighter child headform and to have a larger crush depth in the transition area than required for just one headform mass. As discussed in Section 3, this overlapping requirement matches real-life accident data which show that there is an

overlapping zone hit by the heads of both tall children with lighter heads and short adults with heavier heads. This overlapping requirement means that a larger crush depth is required in this area. Large crush depth under the bonnet (and wing edges if within the test area) is difficult to provide and could result in the bonnet height having to be significantly increased in this area, which has implications for view angles. Therefore, there could be feasibility problems in this transition area, particularly for some styles of vehicle. However, the change in child headform mass recommended in Section 3 from 2.5 kg to 3.5 kg will reduce the differences in mass between the two headforms and therefore this feasibility problem. The use of one of the alternative 4.5 kg adult headforms instead of the phase two 4.8 kg headform was discussed in Section 3 and it should be noted that use of the slightly lighter 4.5 kg headform would further reduce the difference between the two headforms and therefore further reduce the feasibility problems around the switch between child and adult. In addition, it is recommended that a zone within the main bonnet top test area, where the performance requirements are less demanding, be introduced to help improve the feasibility in areas where protection is particularly difficult. This relaxation zone could take a similar form to the nominated one third HIC 2000 zone in phase one of the Directive.

7.2.6.4 Worldwide harmonisation

The use of different test methods and test tools in regulations in different countries could also lead to problems for vehicle manufacturers who wish to sell the same vehicle models worldwide, as the vehicles will have to meet the applicable regulations for all regions. At the simplest level, this may just cause further testing expenses. However, where test methods are different from one region to the next, then some areas of the vehicle might have to pass more than one test requirement. At present the EC Directive is the only approved pedestrian protection regulation, however, the Japanese MLIT pedestrian head procedure is due to be finalised soon and other pedestrian test procedures such as IHRA, GTR and ISO could also be incorporated in legislation in the future. Therefore, there could potentially be different pedestrian requirements in different countries. However, this will only be a problem for vehicles approved worldwide if there is a conflict between the test requirements. If the proposals to change the headforms used in the second phase of the EC Directive are accepted then there will be no significant conflicts between any of the current pedestrian test procedures. Although some pedestrian procedures have more demanding (higher speed) tests and some tests of extra areas of the vehicle, provided that the most demanding requirement is met then the vehicle should also be able to pass the others.

It is also possible that pedestrian protection requirements could conflict with other regulatory requirements, as discussed above in Section 7.2. Although no fundamental conflicts have been found, it is thought likely that for some types of vehicle it may be difficult to meet both phase two of the EC pedestrian protection Directive and the most demanding bumper damageability requirements, those of Canada. It is recommended that the Canadian authorities consider whether they have the correct balance between minimising vehicle disablement / repair costs and pedestrian protection. If, due to their demographic, environment and climatic situation or any other special national requirements, it is shown that the consequences of vehicle disablement due to damageability are more serious than the potential savings in pedestrians injured then it might be reasonable not to have full harmonisation and special national editions of a vehicle model would be justified.

7.2.7 Limitations of deployable systems and conflicts with surfaces that remain

As discussed in Section 4, only deployable or pop-up bonnets, triggered by some form of bumper contact switch, are thought to be sufficiently well developed for use in the near future. Systems of this type are likely to be arranged so that they only deploy at speeds broadly around 40 km/h and do not deploy at very low or very high speeds. One reasonable requirement would therefore be to require the system to absorb sufficient energy in the down position that it would be safe for head impacts at a speed of, for example, the minimum trigger speed plus 10 percent. It would also be reasonable to require it to deploy with sufficient speed that it would be safely raised before head contact so that

protection is provided with full bonnet lift at speeds of up to at least 55 km/h. This may also require the upper activation cut-off velocity to be set with some safety margin, to minimise the risk of the head of a pedestrian striking an upward moving bonnet. However, it may be that in high-speed impacts it is on balance safer to be hit by a still deploying bonnet rather than by one that has not been deployed, particularly when the bonnet is in the stabilisation phase rather than the main lift phase; in this case the upper activation cut-off velocity should be set to a higher value. It should also be noted that the lower and upper activation cut-off velocities will relate to vehicle speed, and in the case of head-on and tail-on pedal cycle impacts this could mean that the system does not deploy in accidents where the closing speed is close to the 40 km/h speed that the test procedures are designed for.

However, although the rules suggested above are reasonable they will probably need to be tailored for each vehicle and system. If these or similar rules are applied then the protection provided will generally match or exceed (due to larger crush depths) that of a passive deforming solution, up to the upper activation cut-off speed, but above that speed it would provide less protection than a non-deploying system. Depending on the cut-off speed this would mean that a small number of generally above-average strength pedestrians would not be saved in high-speed accidents. Nevertheless, as pop-up solutions, due to their cost, are thought likely to be used only on vehicles where conventional deformation methods are not practical, this compromise is thought acceptable.

A further possible complication with deployable systems is how the pedestrian would interact with it when impacts overlap with the remaining 'fixed' surfaces. It is thought that there could potentially be two main areas of concern. The first is the wing edge and the second is the scuttle area behind the raised bonnet.

It is recommended that the side reference lines be determined with the bonnet down, as otherwise the edges of raised bonnet could in some cases inappropriately form the side reference lines. Also, the area where impact points can be chosen, at least a headform radius in from the side reference lines, should be established with the bonnet down. However, if there are impact points on the wings these should be tested with the bonnet deployed, even if this means that the headform when aimed at the 'impact' point makes a glancing impact with the edge of the bonnet instead or as well as a wing impact. In such cases the headform will not make first contact with the defined 'impact' location so the normal tolerance on achieving the correct impact location should be waived. Manufacturers that design in a deployable bonnet will want to avoid the complication of testing the wing edge, which is often a difficult area to make safe, so they are almost certainly going to ensure that the deployed bonnet covers the full width of the 'effective' tested area, i.e. the full width that receives a significant impact, although the wing may still see a low-energy secondary impact. In the case of a double contact with bonnet and wing, irrespective of which was the defined impact, these should both be considered as part of the main impact for the purposes of determining the HIC value. For vehicles with a pop-up bonnet inside the side reference line the test authorities will be able to select test positions with the worst combination of bonnet and wing edge impact.

For vehicles where the headform test area extends behind the rear edge of the pop-up bonnet, it is again recommended that the rear reference line and a line one headform radius forward of it, be marked in the non-deployed position and the bonnet be tested in the raised position. Again the authorities will be able to select the worst combination of bonnet and scuttle impact for the head. However, in this case it is possible to imagine that in real life, some unfortunate loadings could occur to the pedestrian's neck for example. It is not thought possible to provide a generic rule to examine the risk of this type of loading but it is recommended that manufacturers provide proof that this risk has been considered and minimised, when they provide the proof required in the Directive that the system works as intended.

In a similar way some deployable systems may affect measuring up and testing for the bumper and bonnet leading edge tests. These could include deployable systems in those impact areas if they used pre-impact trigger systems. Deployable bonnets could affect both bumper and bonnet leading edge impacts if they deployed before or during those phases of an impact with a pedestrian. This would probably not be the case with post-impact triggering but probably would be with pre-impact triggering. The bonnet leading edge reference line should be determined with the bonnet deployed if

the bonnet is likely to be deployed for the bonnet leading edge stage of a pedestrian impact. This reference line is sensitive to the bonnet angle so bonnet deployment could change it even though the bonnet only pivots about this area.

With any system involving airbags the impactor will not make first contact with the defined 'impact' location, so the normal tolerance on achieving the correct impact location should be waived or modified as necessary to be a tolerance on impact trajectory instead.

Consideration will be needed with each deployable system as to whether it can be deployed and then tested at some later time or whether the impactor will have to be delivered at approximately or precisely the correct time, as determined from simulation or dummy tests. A correctly timed impact could be achieved by linking the propulsion system release to the trigger circuit of the deployable system.

The development of a prototype sensor legform designed to test the trigger system of a pop-up bonnet is described in Section 5.2. This prototype sensor testing legform was designed to test a specific type of bumper contact switch. It is thought to be essential that each type of trigger be tested as it is to be used on the vehicle, with a test device that matches the human properties that the trigger system is intended to be sensitive to. The trigger test tool must also represent the full range or worst-case pedestrian statures and pedestrian motions likely to occur in real life. In most cases it is thought that this means that the sensor test tool will not be the same as the EEVC legform impactor. For deployable systems, because of the need to tailor the sensor test device to the technology used, it is not possible to provide firm rules for the test programme needed to show that it 'works as intended' as required in the Directive. However, it is recommended that some form of generic protocol be produced, to guide the testing of both the trigger and the whole deployable system to show that it works as intended. A protocol was proposed by Chinn and Holding (2003) in their guide to assessing active adaptive secondary safety systems.

To meet the HIC requirement using the minimum crush depth, the bonnet must have a uniform and appropriate deformation stiffness. Pop-up bonnet systems offer the benefit of increasing the available crush depth over the hard underlying structures in the engine bay. However, due to the short time available for activation it must be stiff enough to avoid plastic deformations when lifted and to avoid excessive oscillations during the lifting and arresting phases. As failure to trigger would be unacceptable, the triggering algorithm is likely to be set such that it will give the benefit of the doubt to the pedestrian, so that on some occasions it will fire the bonnet when unnecessary (when hitting a traffic cone). In this case damage to the bonnet during the lift would be unacceptable because it would result in prohibitively high repair or resetting costs. Excessive bonnet oscillation excited during the lift and arrest phases could add to the head acceleration and increase the risk of head injury. This should also be minimised.

It can be seen that there could be some conflict between the stiffness required to provide pedestrian head protection and that needed for the bonnet to operate as required. Some mathematical simulation results were provided by a sports car manufacturer of a bonnet that was designed to comply with phase one of the EC Directive. These showed that it met the phase one requirements, but when tested to phase two there were some high child HIC values in the hinge area and around the reinforcement that had been added to resist damage during activation. It is thought likely that this problem could not be resolved fully by optimising the bonnet for phase two. However, the increase in child headform mass proposed in Section 3 is thought likely to partially or completely resolve this problem and the option to nominate any remaining problem areas for the relaxed test requirement should remove any final concerns regarding feasibility.

7.3 Discussion of feasibility

When proposing the negotiated agreement, ACEA also proposed that a feasibility study was required for the second, more difficult phase. This proposal was accepted by the European Commission and they produced a specification for the study reported here. By supplying data to the contractor, TRL, the car industry has taken the opportunity to present formally their data and observations on feasibility

issues. Two of the manufacturers that were visited reported results of tests / simulations on experimental vehicles, consisting of a combination of a modified mule vehicle and simulated vehicles, that were made to meet, as far as was thought feasible, the phase two requirements. In addition, one manufacturer presented results of a vehicle close to launch, that was designed to meet phase one but had also been assessed to phase two using mathematical simulation. These results highlighted a number of feasibility issues but made no suggestions as to what changes were necessary to make phase two feasible. Following the meetings with TRL, one manufacturer supplied results of a programme of mathematical simulations that was aimed at showing the maximum protection that could be achieved in phase two. These results were particularly useful as they took into account the possible changes to phase two that had been outlined by TRL in their visit.

One way to determine whether the pedestrian protection requirements are fundamentally in conflict with current vehicle designs is to examine test results. The Honda Civic was tested by Euro NCAP using EEVC WG10 test methods (Euro NCAP, 2001) and again by TRL using EEVC WG17 test methods (Lawrence *et al.*, 2002). The TRL test results showed that much of the Civic's bumper and the bonnet leading edge passed the EEVC WG17 requirements with the remainder close to passing and some areas of the bonnet top passed the child headform requirement, with much of the remaining areas being reasonably close to passing. EEVC WG17 introduced a small reduction in the bonnet top test area by changing the bonnet rear reference line definition. This resulted in no adult tests in the TRL study of the Civic however, the windscreen base was tested in the Euro NCAP tests and two adult headform passes were obtained.

Although no one car in the Euro NCAP programmes of pedestrian tests has met all of the protection requirements of phase two of the EC Directive over the full test area, the results have shown that areas of some of the vehicles do comply with the requirements. Examination of Euro NCAP data show that examples of areas passing each of the test tool performance requirements (to EEVC WG17 and Directive phase two) can be found on many vehicles, although not necessarily for all of the test area or all of the test tools on the same vehicle. These results show that the stiffness and crush depths required for pedestrian protection are already considered acceptable in some areas of current designs. However, before more conclusions on feasibility are drawn from the Euro NCAP data, it is important to determine whether the manufacturers of the cars tested were making any strenuous efforts to provide pedestrian protection. Over the years that the Euro NCAP test programme has been running, many of the cars have been tested at TRL and, when time was available, they have been examined to determine the cause of good and poor pedestrian protection. Although not exhaustive, this monitoring by TRL has suggested that with a few more recent exceptions little effort has been made to provide pedestrian protection. This is thought to be due to manufacturers responding to consumers showing less interest in pedestrian protection than in occupant protection. Therefore, although overall the pedestrian protection of cars tested by Euro NCAP is poor, this is not proof that phase two of the EC Directive is infeasible. Rather, the improvements seen in the few models where some effort was made to enhance pedestrian protection show that significant protection is feasible, although the protection does not necessarily meet in full the current requirements of the second phase of the EC Directive.

7.4 Implications of feasibility issues for the Directive

For compliance of a vehicle with the EC Directive and the ensuing type approval, all variants of the vehicle must be covered. This includes all combinations of available engines, power-trains, equipment and trim. Therefore the 'worst case' combination needs to be taken into account for the design envelope. Considering head and upper leg impacts, this would probably be the largest engine variant as this is likely to give the smallest available crush depth between the bonnet outer skin and the hard underlying engine surface. If compliance with the Directive is not thought to be feasible for the 'worst case', as has been suggested by manufacturers during visits by TRL, then unless some changes are made to phase two some types of cars would need to be removed from the market due to the 'technical impossibilities' of passing the requirements. Worse still, if it proves unfeasible to make

vehicles that have the entire test area meeting the phase two performance criteria, it will be impossible to obtain approval for new vehicle designs.

Suggestions have been made in Section 3 to improve the test methods and these changes, if accepted, would also have the effect of improving the feasibility of meeting phase two of the Directive. Overall, TRL have concluded that pedestrian protection to meet these revised requirements would be feasible in principle, without the need for the additional feasibility changes outlined above. However, when all the vehicle performance requirements discussed above are considered in conjunction with the wide range of vehicle styles and variants currently available, TRL have concluded that it will be necessary to introduce additional feasibility measures.

7.4.1 Improvements to the test methods and changes for feasibility

For this study, data have been gathered on feasibility issues from a number of sources including discussions with car manufacturers, examination of cars with good pedestrian protection and TRL's experience over a number of years. These issues have been judged primarily against the current requirements in the second phase of the EC Directive. However, a number of changes to improve the test methods have been suggested in Section 3. As most if not all of these changes affect the feasibility of providing protection, they also need to be considered when proposing changes on feasibility grounds.

As discussed in Section 3.3, one effect of legislative requirements is that, in practice, car manufacturers have to achieve a higher level of protection than the minimum requirements. This higher level of protection is required, firstly, to ensure that the first few vehicles produced for regulatory approval tests actually pass. Secondly, following approval they are required to ensure that when the vehicle is in mass production that the 'worst' combination of manufacturing and test variations would not result in a vehicle that would exceed the performance requirements. The net effect of this is that manufacturers typically aim to be inside the protection requirements by about 20 or 25 percent and, in addition, they will have to allow some extra crush depth in case the vehicle is slightly softer than intended. These manufacturers' additional tolerances are likely to mean that typically most vehicles will protect a greater portion of the population at the intended impact speed and be safe for most pedestrians at slightly higher speeds than the intended impact speed, which in the case of the second stage of the EC pedestrian protection Directive is 40 km/h. Obviously, with most regulations this is not a problem as it results in additional savings; however, in this case these extra margins make the regulation less feasible. As concluded above, it is necessary to introduce additional measures to improve feasibility. One option for doing this is to increase the performance criteria by the manufacturer's allowance. The net effect of this option will be that the average performance of the cars produced will meet the intended protection levels but some cars, or locations on them, will be slightly worse than intended and some slightly better.

Therefore, it is recommended that, where appropriate, the criteria of phase two be increased by 25 percent. This will result in the actual protection level achieved being, on balance, about what was originally intended, if a manufacturer applies a 20 percent approval / conformity of production allowance, and slightly more than originally intended if they apply a larger allowance. Elsewhere the manufacturers' allowance could be taken advantage of to provide more protection than originally intended or to provide added confidence where thought necessary. Specific proposals are made for each test procedure in the following sections.

The proposal, in Section 7.2.5.1, that for each test area the manufacturer should be allowed to nominate part of the test width or test area as a 'difficult area', attracting a less demanding protection requirement, is thought to significantly improve the feasibility of the second phase of the Directive. For brevity this concession is referred to as a 'nominated relaxation zone' below.

Below, the changes to the test tools, methods and criteria proposed in Section 3 are restated, along with proposed changes to take account of feasibility issues so that the combined effects on feasibility can be considered. Together these changes are thought by TRL to make phase two of the EC Directive 'feasible'. In this context this means feasible for almost all vehicles if some reasonable

level of changes to future vehicle designs are accepted. It does not necessarily mean that all existing niche or specialist vehicles can be made to meet the requirements without significant changes, which may be deemed by some as unreasonable.

The changes presented in the following sections (Sections 7.4.1.1, 7.4.1.2, 7.4.1.3 and 7.4.1.4), use two expressions to indicate the strength of the recommendations. The highest levels of recommendation made will use the words 'strongly recommended' and this expression will be used when the proposals are thought to resolve serious feasibility issues and / or improve the science of the test methods. The second level of recommendation uses the word 'recommended that consideration should be given to' and this expression will be used where changes for feasibility issues or recommendations for further research are thought to be beneficial but are not necessarily essential.

Although these proposals are for a complete package that could be used to revise the phase two test methods and requirements, there are a few technical issues where some further work might be required. It is recommended that the opinion of the EEVC Pedestrian Safety Working Group (WG17) be sought here.

The EC Directive does not have a tolerance for the accuracy with which impact speed is measured and it is strongly recommended that such a tolerance be introduced for all test procedures. It is recommended that consideration be given to introducing the Euro NCAP tolerance of ± 0.02 m/s in phase two of the EC Directive. This will help manufacturers by reducing test variability.

7.4.1.1 Legform test

Although manufacturers have expressed some concerns about meeting the requirements of phase two of the Directive, most appeared to have concluded that it would be feasible. There are no new technological developments to aid the protection of pedestrians in the bumper area that are at a stage of development so as to be available for use to meet phase two of the Directive. There are a number of functional and legislative requirements that overlap with this test but overall the data reviewed suggest that protection to the phase two requirements is feasible. Proposals have been made to improve the legform-to-bumper test method in Section 3 and these are also thought to reduce the difficulty of meeting the protection requirements, by making the test easier to pass or by making it more repeatable. These proposals are listed below:

- Add a shoe thickness allowance so that the foot end of the impactor is required to be 25 mm from the ground at first contact;
- Halve the legform height and verticality (in the longitudinal plane) tolerances at first point of contact to ± 5 mm and $\pm 1^\circ$;
- Increase the knee bending angle performance criterion from 15° to 19° (as recommended in Section 3.3.1.4);
- Add new requirements for the relative humidity to be controlled to $35 \pm 15\%$ in the vehicle test and to $35 \pm 10\%$ in the legform dynamic certification test.

All of the above changes to improve the test methods are strongly recommended. In addition it is recommended that consideration should be given to carrying out further research on the effects of humidity on the performance of the Confor™ foam flesh in the dynamic legform certification test; the results of which could be used to confirm or adjust the humidity and pass / fail tolerances.

There are two options for manufacturers of vehicles with high bumpers for off-road use. The first is to provide sufficient bumper deformation to pass the upper legform to high bumper test. The second is to lower the lower edge of the bumper so that it is no longer a high bumper. This will mean that it will be required to meet the legform protection criteria. The only way that this latter option can be made feasible, while maintaining a full off-road capability (large ramp angle), is thought to be the use of an adjustable or removable spoiler type unit. However, a spoiler device of this type could be inadvertently or deliberately left in the up position by the driver, when the vehicle is used on public

roads. Therefore it is recommended that a code of practice be established that provides guidance on appropriate methods to prevent misuse. This could take the form of requiring the manufacturer to provide appropriate labels, warning lights, interlocks, or clear instructions in the user manual, that the device must be fitted (if removable) or in the down position (if movable) when the vehicle is used on public roads. The documentation would need to state that the spoiler is only to be removed or moved up for off-road use. The recommendation that the spoiler would significantly improve the fuel economy of the vehicle may be useful in persuading the owner to keep the spoiler fitted or in the down position when the vehicle is used on public roads.

Proposals have been made for changes to take account of feasibility issues discussed in earlier parts of this section. These proposals are listed below along with comments in italics:

- Increase the acceleration protection requirement for the bumper from 150 g to 190 g. *(This change to the acceleration criterion is to take account of the manufacturers' 20 percent approval / conformity of production allowance. It is not proposed that the bending angle or knee shear be increased in a similar way because it is more important to prevent knee joint injuries than lower leg fractures.)*
- Allow manufacturers to nominate bumper test widths of up to 264 mm in total, for testing with an acceleration protection requirement of 250 g. *(This will provide a more controlled relaxation than currently allowed in phase one where derogation (no test) is allowed for a removable towing hook. Again it is not proposed that the bending angle or knee shear be increased in a similar way for the reason set out above. It is thought more reasonable not to link this relaxation to specific features such as towing eyes so that it can be used for any difficult area.)*

All of the above changes for feasibility are strongly recommended.

7.4.1.2 High bumper test

There are no new technological developments to aid the protection of pedestrians in the bumper area that are at such a stage of development so as to be available for use to meet phase two of the Directive, so it will be necessary to absorb the test energy by deformation.

Proposals have been made to improve the upper legform to high bumper test method in Section 3 and these are also thought to make the test more appropriate and more repeatable. These proposals are listed below along with comments in italics:

- Test high bumpers only with the upper legform impactor, i.e. withdraw the option for manufacturers to choose between testing with the legform or the upper legform impactor. *(The upper legform impactor is a more appropriate tool for testing high bumpers.)*
- Revise the definition of the 'Upper Bumper Reference Line' so that the centreline of the upper legform impactor is aligned with the centre of the bumper structure. The revised wording proposed in Section 3.3.2 can be used for this or any alternative thought better by WG17. *(Originally the upper bumper reference line was only used to determine the bumper lead for the bonnet leading edge test. When adopting this line for their new high bumper test, WG17 failed to notice that for the higher 'high bumpers', this would result in the upper legform to bumper test not being centred about the 'real' bumper front face.)*
- Where permanent towing hooks are positioned beneath a high bumper, in such a position that they are not contacted by the upper legform impactor in the test, then they must be set back at least 120 mm behind the front face of the bumper.
- Add a new requirement for the relative humidity to be controlled to $35 \pm 15\%$ in the vehicle test and to $35 \pm 10\%$ in the upper legform dynamic certification test.

All of the above changes to improve the test methods are strongly recommended. In addition it is recommended that consideration should be given to applying, to the upper legform to high bumper test, any changes to the humidity tolerances that may be recommended by further research on the effects of humidity on the performance of the Confor™ foam flesh in the legform dynamic certification test.

Proposals have been made for changes to take account of feasibility issues discussed in earlier parts of this section. These proposals are listed below along with comments in italics:

- Increase the force and bending protection requirement for the high bumper from 5 kN to 6.25 kN and from 300 Nm to 375 Nm. *(These changes to the force and bending criteria are to take account of the manufacturers' 20 percent approval / conformity of production allowance.)*
- Allow manufacturers to nominate bumper test widths of up to 264 mm in total, for testing with force and bending moment protection requirements of 7.5 kN and 510 Nm respectively. *(This will provide relaxation for difficult areas and can be used to reduce the risk of failure to obtain approval late in the vehicles development.)*

All of the above changes for feasibility are strongly recommended.

7.4.1.3 Upper legform to bonnet leading edge test

All of the manufacturers spoken to, who made vehicles of such a shape that an upper legform to bonnet leading edge test was required, were unanimous in expressing concern about the feasibility of meeting the protection criteria in this area, mainly due to a lack of crush space, rigidity and packaging issues. There are no new technological developments to aid the protection of pedestrians in the bonnet leading edge area that are at such a stage of development so as to be available for use before the introduction of phase two of the Directive. However, proposals have been made to improve the upper legform to bonnet leading edge test method in Section 3 and these are also thought to make the test more feasible and more repeatable. These proposals are listed below along with comments in italics:

- Change the angle of the straight edge used to determine the bonnet leading edge reference line from 50 degrees to the vertical to 40 degrees. *(This will identify more accurately the centre of the upper leg impact.)*
- Replace the current upper legform test energy graph and interpolation rules with the revised one proposed in Section 3.3.3.3. *(These revised energies are based on simulations made with a more biofidelic pedestrian model than previously used and include an additional adjustment to make them more representative of a 'live' human.)*
- Review the current test velocity curves in conjunction with the new energy curves and adjust the velocity curves as necessary so they do not require an impactor mass below 9.5 kg. *(9.5 kg is the minimum practical mass that can be achieved with a robust impactor and guidance system.)*
- Add a new requirement for the relative humidity to be controlled to $35 \pm 15\%$ in the vehicle test and to $35 \pm 10\%$ in the upper legform dynamic certification test.

All of the above changes to improve the test methods are strongly recommended. It should be noted that there was insufficient time within this project to produce the required adjusted velocity curve. In addition it is recommended that consideration should be given to applying, to the upper legform to bonnet leading edge test, any changes to the humidity tolerances that may be recommended by further research on the effects of humidity on the performance of the Confor™ foam flesh in the legform dynamic certification test.

Proposals have been made for changes to take account of feasibility issues discussed in earlier parts of this section. These proposals are listed below along with comments in italics:

- Reduce the energy cap from 700 J to 500 J. *(This should make the test feasible for taller vehicles.)*
- Increase the force and bending moment protection requirements for the bonnet leading edge test from 5 kN to 6.25 kN and from 300 Nm to 375 Nm. *(These changes to the force and bending moment criteria are to take account of the manufacturers' 20 percent approval / conformity of production allowance.)*
- Allow manufacturers to nominate bonnet leading edge test widths of up to 300 mm in total for testing with force and bending moment protection requirements of 7.5 kN and 510 Nm respectively. *(This will provide relaxation for difficult areas and can be used to reduce the risk of failure to obtain approval late in the vehicle's development.)*

All of the above changes for feasibility are strongly recommended.

7.4.1.4 Child and adult headform tests

Research and current good vehicles show that large parts of the headform test area can provide significant levels of head protection, however, protection to the phase two requirement for the full area is not thought to be 'feasible' in problem areas such as the wing edge and bonnet hinge area. The concern about the feasibility of providing the low stiffness implied by a 2.5 kg child headform, and the change in bonnet stiffness needed between the child and adult head test areas, are addressed by the proposed changes of mass to both headforms and the provision of a relaxation zone.

A proposal has been made to improve the child headform test method in Section 3 and this is thought to make the test more appropriate. The proposal is listed below along with comments in italics:

- Replace the 2.5 kg child headform impactor with the current 3.5 kg headform impactor, as used in phase one, for testing the child test area (between the 1000 mm and 1500 mm Wrap Around Distance and the Side Reference Lines). Retain the phase two test velocity of 40 km/h. *(As well as being more appropriate and harmonising with other head test methods, this will reduce the problem of having to make the child area excessively weak and reduce the problems due to the change in headform mass about the 1500 mm line between the child and adult areas.)*
- Replace the 2.5 kg child headform certification method with the current 3.5 kg headform dynamic certification method and limits, as used in EC Directive phase one.
- Replace all references to spacing for child test point selection based on the radius and diameter of the 2.5 kg headform (65 mm and 130 mm) with those of the for the 3.5 kg headform (82.5 mm and 165 mm).

All of the above changes, to improve the test methods, are strongly recommended.

Proposals have been made for changes to take account of feasibility issues discussed in earlier parts of this section. These proposals are listed below along with comments in italics:

- Replace the 4.8 kg adult headform impactor with a 4.5 kg headform impactor for testing the adult test area [between the 1500 mm Wrap Around Distance and the Bonnet Rear Reference Line (or 2100 mm for vehicles with long bonnets) and the Side Reference Lines]. Retain the phase two test velocity of 40 km/h. *(As well as harmonising with other head test methods this will reduce the problems due to the change in headform mass about the 1500 mm line between the child and adult areas.)*
- Replace the 4.8 kg adult headform specification with a revised one for a similar impactor design and flesh but with a reduced mass of 4.5 kg. *(This could be a modified version of the current WG17 specification or could be produced by adapting or adopting the specification for the Japanese 4.5 kg headform impactor.)*

- Replace the 4.8 kg adult headform certification pass / fail limits with ones appropriate for the chosen 4.5 kg headform tested to the current procedure. *(Currently there are no 4.5 kg values for a WG17 type test.)*
- Increase the HIC protection requirement for the bonnet top (child and adult test areas) from HIC 1000 to HIC 1250. *(This change to the HIC criterion is to take account of the manufacturers' 20 percent approval / conformity of production allowance.)*
- Allow manufacturers to nominate up to 25 percent of the child and up to 25 percent of the adult bonnet top test areas, for testing with head protection requirements of HIC 2000. *(This will provide relaxation for difficult areas and can be used to reduce the risk of failure to obtain approval late in the vehicle's development.)*
- For vehicles of such a size that all parts of the bonnet rear reference line are at a wrap round distance of 1700 mm or less, any adult test area will be defined as a 'small adult area'. Small adult areas can be tested, point-by-point, with either the child headform or the adult headform, based on the manufacturer's nominated child and adult areas within the specified small adult area. For a small adult area, up to 25 percent of the area can be nominated for the HIC 2000 test, with this 25 percent of the area apportioned to the child or adult headform test in the same ratio as for the whole of the small adult area. *(To improve feasibility for vehicles with bonnets of such a length that nearly all of the bonnet top test area is within the child zone, but small adult areas exist.)*

All of the above changes for feasibility are strongly recommended. In addition, it is strongly recommended that the views of WG17 be obtained in producing the revised 4.5 kg adult headform specification and certification limits.

8 Review of system costs

To limit the severity of an impact for a pedestrian when hit by a car, protective features need to be designed into the vehicle. Any feature introduced to protect pedestrians may compromise other features of the vehicle design as discussed in Section 7. In addition to any compromise, or 'trade-off,' the pedestrian protection feature will also have associated costs. These associated costs are likely to consist of costs for development, production, fitting, etc. The following section attempts to derive the production costs for each of the individual features needed to protect pedestrians.

The features for which a cost is to be derived come from a breakdown of the general performance that a pedestrian friendly vehicle would exhibit. For example, in the bumper area, it is known that the correct stiffness, force distribution and crush depth are required. To achieve this it may require having the bumper beam set well back from the leading edge, having a spoiler well forward with respect to the bumper and tailoring the energy absorption by insertion of foam between the bumper fascia and the bumper beam. These design characteristics are the features that will be used to give costs for providing the protection. To simplify the issues required to provide protection for pedestrians, the features have been separated into the areas that would be tested in phase two of the EC Directive as these are the regulatory tests that will assess pedestrian protection.

The design requirements for protection of pedestrians as identified in the following sections and in Section 2, may force compromises with the issues raised in Section 7. Ideally, to account for the feasibility of the system and give values of the greatest available accuracy, costs from the vehicle manufacturers are required. However, manufacturers are not yet in a position to provide such costs because they are concentrating on meeting phase one. The one exception found to this was with a vehicle manufacturer who was incorporating a pop-up bonnet system to meet phase one. In addition, cost data for a pop-up bonnet system were also available from a tier one supplier. It is thought that the pop-up system could be refined to meet the proposed modified phase two requirements, as outlined in Section 7, without additional cost. Therefore these costs can be used unchanged for a phase two pop-up bonnet system. The changes to the test methods outlined in Section 7 are a combination of improvements to the test methods and changes thought necessary for feasibility. Therefore by estimating costs based on the proposed revised phase two requirements, the costs should relate to feasible solutions. However, they will not completely take into account the more intangible trade off between changes in styling and manufacturing costs.

The aim of this and the following section is to produce estimates of the average additional costs for pedestrian protection for each main class of vehicle sold in Europe. However, in order to identify the pedestrian protection changes needed, with the necessary detail to produce cost estimates, it was decided to examine in detail two existing vehicles to identify the changes necessary. These detailed changes were then subjected to a cost study on the basis of making a totally new vehicle design. The new vehicle would be of the same vehicle segment and have similar architecture to the existing vehicle.

Two vehicles were selected for the detailed cost exercise, a Landrover Freelander and a Ford Mondeo. These vehicles were selected because it was thought that between them they provided an example of all of the changes necessary to make the whole vehicle fleet meet the proposed revised phase two of the EC Directive, with the exception of a pop-up bonnet. The detailed cost exercise has the advantage that the consequences of these changes can also be identified along with the costs of incorporating them in a complete functioning vehicle. These costs are effectively for a completely new version, the next generation, of Freelander and Mondeo with pedestrian protection but not for the whole European vehicle fleet. Nevertheless, as they provide costs for all of the changes likely to be necessary to make the fleet comply with the revised phase two Directive requirements, they can be used with suitable weighting to determine a generic cost for each vehicle segment. These can then be combined to produce an estimated fleet cost. The process of weighting and combining these costs to produce a fleet cost is described in Section 9 following.

For these two vehicles, the areas needing improvement for the protection of pedestrians were identified by TRL and modifications were suggested to address the issues.

8.1 Estimating the changes needed

As noted in Section 2, the three design concepts needed for pedestrian protection are sufficient crush depth, appropriate deformation stiffness and appropriate force distribution. Where a vehicle is deficient in one or more of these concepts, with regards to that required to meet the proposed requirements for phase two of the EC Directive, then modifications will be required. To establish whether any and what modifications are required, it is necessary to know what is required to meet the proposed phase two criteria. For each of the sub-system tests the protection measures can be estimated in terms of crush depth, stiffness and profile and these will be different for different vehicle styles and sectors. The practical minimum crush depths have been estimated for the two vehicles selected for each sub-system test. These have been calculated by making a number of assumptions including meeting the criteria or criterion. The results of these calculations are presented below for each of the test areas and are made on the basis of the proposed changes to the phase two requirements summarised in Section 7.

Other changes necessary to obtain the required shape and stiffness are proposed later where a series of specific changes have been proposed by TRL for the two vehicles.

8.1.1 Legform to bumper

For the purposes of the crush depth calculation, it is assumed that manufacturers use a 20 percent allowance on criteria. This will mean that the manufacturers' target values are about 150 g (190 g x 0.8) and 15.2 degrees (19° x 0.8).

As discussed in Section 7, it is proposed to have a relaxation zone, a maximum total of 264 mm of the legform test width; for this the acceleration limit will be increased to 250 g which will give a manufacturers' target of 200 g.

As tibia acceleration is the criterion that dictates crush depth, it is possible to make a calculation of the required practical crush depth for a tibia acceleration of 190 and 250 g by making the following assumptions:

- Manufacturers' targets are ~150 and 200 g
- Overall energy efficiency of the impactor flesh is 25 percent
- Thickness of the flesh is 25 mm
- Proportional crush of the flesh is 80 percent of thickness
- Energy efficiency of the bumper structure is 65 percent
- Energy absorbing materials in the bumper bottom out at 10 percent of their original thickness (i.e. 90 percent crush)

Energy efficiency here is the ratio of the average acceleration to the peak acceleration, with the latter taken to be the manufacturers' target acceleration.

These parameters can be used to give crush depths of 62 mm for the 190 g zone and 45 mm for the 250 g relaxation zone.

The 45 or 62 mm of pedestrian protection crush will also help the vehicle pass the Part 581 bumper test, as described in Section 7. Therefore some of the crush depth allocated to passing the Part 581 test can also be allocated to pedestrian protection. The Part 581 test requires the bumper to absorb the energy of a pendulum of the same weight as the vehicle, impacting the bumper at 2.5 mph (4.0 km/h), with the impacting face of the pendulum representing a standardised bumper, 24 inches (0.61 m) wide. The contribution that the crush depth of the pedestrian protection bumper makes to passing this test can be estimated using the following calculation chain:

The kinetic energy in the pendulum can be found from Equation 8.1:

$$E = \frac{mv^2}{2} \quad \text{Equation 8.1}$$

For the Part 581 bumper test 'v' will be 2.5 mph (1.11 m/s). The pendulum mass has to equal the vehicle mass; if this is assumed to be 1000 kg, then the formula gives an energy of 617 J. For the similar Canadian bumper test, the speed is 5 mph (2.24 m/s) so using the same assumed mass, the pendulum energy for this test would be 2464 J.

The contact area of the pendulum acting on the pedestrian protection energy absorbing material will be approximately the pendulum's width (24 inches), multiplied by its effective depth. As the depth of the bumper face part of the pendulum is narrower than most bumpers, its depth will control the contact depth. The pendulum depth increases from 4.5 inches (114 mm) at the face to about 6 inches (152 mm) at the rear. If an average depth of 5.25 inches (133 mm) is assumed then the contact area will be approximately 24 x 5.25 inches, which equals 126 inches² or 0.08 m².

The crushing force per unit area of the bumper energy absorbing material (typically foam) for the pedestrian test can be estimated through the relationship of force divided by impact area. For a flexible bumper facia, the impact area is approximately 120 mm wide (as can be seen in Figure 8.1 below, where Hexcel was fitted behind the bumper facia of an experimental bumper) multiplied by the depth of the bumper, which is likely to be approximately 200 mm.



Figure 8.1. Crush of Hexcel following a pedestrian legform test

Therefore the area is about 0.024 m². If an effective mass of the legform of 5.2 kg is assumed (the effective mass will be lower than the total mass due to the knee deforming) and an average impact acceleration of 100 g, then the force can be calculated by multiplying these as follows:

$$5.2 \text{ kg} \times 1000 \text{ m/s}^2 = 5.2 \text{ kN}$$

An estimate of the pedestrian foam's crushing force per unit area can then be obtained by dividing the force by the area, which gives a value of 217000 N/m².

The force of the bumper on the pendulum is equal to the crushing force per unit area of the foam multiplied by the pendulum contact area:

$$217000 \text{ N/m}^2 \times 0.08 \text{ m}^2 = 17.3 \text{ kN.}$$

The pendulum energy removed by the pedestrian foam is the force multiplied by the distance. For the 190 g width, the force is 17.3 kN and the usable crush depth is 56 mm, which gives 970 J. For the 250 g nominated relaxation zone, a larger force is allowed which permits the crush depth to be reduced; however the stronger energy-absorbing material permitted will absorb about the same amount of energy per unit area as in the main zone, over the available crush depth. Therefore, the relaxation zone can be ignored in this calculation.

Both the American and Canadian tests require that the vehicle suffers no visible damage in these tests, so it is important to prevent the impact pendulum penetrating so deep into the bumper that it makes contact with other parts such as the headlamps, bonnet and grille. It is thought likely that because of this, the car manufacturer will currently design to absorb all of the bumper test energy in a crush depth of about 50 mm. A universal world bumper will have to meet the most demanding world requirement, which is the Canadian test. A pedestrian bumper system at the front will absorb some of the bumper test energy and the current protection system (normally crush cans) can be used as a second stage to absorb the remaining energy. Using the assumptions above, the remaining energy will be for the 190 g zone:

$$2464 - 970 = 1494 \text{ J}$$

If an energy absorbing rate of 2464 J in 50 mm is assumed for this second stage then this remaining bumper test energy, 1494 J, can be absorbed in 30 mm of crush. Therefore it can be estimated that the current crush depth of 50 mm will need to be increased to 92 mm (62 + 30 mm). This gives an extra bumper crush length of 42 mm. Had the two crush depths been completely isolated then the crush depth would need to have been extended by 62 mm, the complete pedestrian crush depth for the 190 g zone. However, with some overlapping of the crush depths, only 42 mm of additional crush depth is needed to accommodate the required 62 mm of pedestrian crush depth. This additional crush depth can either be obtained by extending the vehicle length or by improving the efficiency or crush depth of the high speed crash protection zone, so that some of the current length used for high speed protection and packaging of un-crushable elements is available for pedestrian protection. Although it is likely that improvements in energy absorbing efficiency and reductions in the size of engine and transmission packages can be achieved, it has been assumed for this costing exercise that the vehicle will be lengthened.

Obviously, these are very rough calculations so they need to be used with caution but it seems reasonable to conclude that pedestrian and the Canadian bumper test requirements are not completely incompatible and can be met with a relatively compact two stage stiffness system. However, this is only true if a flexible bumper fascia is used so that the area involved in the pedestrian test is lower than that in the Canadian bumper test.

8.1.2 Upper legform to bonnet leading edge

Again it is assumed that manufacturers will make an allowance of 20 percent on criteria. In this area it is assumed that any additional crush depth provided for pedestrian protection will have no benefit for damageability or occupant protection. As the relaxation zone will be used for difficult areas, the remaining bonnet leading edge test area will have to meet the more demanding criteria of the sum of forces being no more than 6.25 kN and the bending moments being no more than 375 Nm. If it is assumed that force is more difficult to achieve than the bending moment, then the required crush depth can be calculated based on the following assumptions:

- The manufacturers' target is 5 kN
- The mass in front of the load transducers is 2.55 kg (this is needed because the measured force at the load transducers behind the front face of the impactor is commensurate with a slightly larger force acting on the vehicle. The difference is related to the ratio of the impactor's mass in front of and behind the transducers)
- Overall energy efficiency of the flesh is 25 percent

- Thickness of the flesh is 50 mm
- Proportional crush of the flesh is 80 percent of thickness
- Energy efficiency of the bonnet leading edge structure is 65 percent

As the test energy is selected on vehicle shape, the crush depth necessary to absorb it is not fixed but is dependent on the vehicle shape at the test location. Therefore, before these assumptions can be used to calculate the crush depth needed for a specific vehicle, the test energy has to be found using appropriate values of Bonnet Leading Edge (BLE) height and bumper lead in conjunction with the new energy look-up graph (Figure 3.10).

8.1.2.1 *Landrover Freelander*

The bonnet leading edge height reference line was marked on the Landrover Freelander using the revised straight edge angle of 40° to the vertical and this showed a typical BLE height of 980 mm and a bumper lead of 165 mm (typical but both vary across the width). Using the new energy curves and energy cap, it can be found that this vehicle attracts a 500 J BLE test with an impactor mass of 9.5 kg and a velocity of 10.26 m/s.

Using the assumptions in Section 8.1.2, an estimated crush depth requirement of 97 mm is calculated.

In addition to this, a 10 mm allowance for the minimum crushed thickness of the material in the BLE and locking platform should also be included, increasing the crush depth required to absorb the test energy within the 5 kN target to about 107 mm. The current Freelander BLE structure has some capacity to absorb energy by deformation and the deformation in the Euro NCAP tests of this vehicle has been estimated from the recorded force to be 78 mm. This leaves a requirement for an additional 29 mm of crush depth. The Euro NCAP results suggest that the current BLE is too stiff, so some change to the stiffness will be needed in addition to this extra crush depth. Any changes to the BLE height or the bumper lead to make the vehicle more pedestrian friendly can change the BLE test energy and therefore the required crush depth. In the case of the Freelander the test energy was kept unchanged through small and similar forward movements of both the bumper and BLE.

8.1.2.2 *Ford Mondeo*

The Mondeo was also measured using the revised BLE straight edge angle. This gave a typical BLE height of 714 mm and a bumper lead of 111 mm. However, it was decided to extend the bumper by 15 mm to make it pass the legform test giving a revised bumper lead of 126 mm. The revised dimensions attract a 454 J BLE test energy with an impactor mass of 14.13 kg and a velocity of 8.0 m/s.

Using these figures and the same assumptions as before for the crush depth calculation, the necessary crush depth required to pass the new proposed upper legform test is 99 mm without the residual crush, and 110 mm with the residual crush.

If the Euro NCAP test results from 2001 are considered, the existing crush depth available in the bonnet leading edge (BLE) can be estimated. These Euro NCAP tests were from a phase where the tests were performed to the WG10 procedures. Based on information from the test, a crush depth of 115 mm was estimated.

Therefore the Mondeo already has 5 mm of spare crush over that required. However the existing crush depth is likely to be too stiff as the original test recorded a high peak impactor force, over that required. As the crush depth to peak force relationship is non-linear, it is difficult to establish the effect of the spare 5 mm and the 'too stiff' bonnet leading edge. With this knowledge though, it is expected that manufacturing changes could be made to meet the proposed requirements, without significant re-design of the structures participating in an impact to the BLE of a Mondeo, at the centreline. The modifications required over the whole width are discussed in more detail in Section 8.2.3.2.

8.1.3 Headform to bonnet top

Again it is assumed that manufacturers will make an allowance of 20 percent on criteria and that in this area any additional crush depth provided for pedestrian protection will have no benefit for damageability or occupant protection.

As discussed in Section 7, it is proposed that the child area be tested at 40 km/h with a 3.5 kg headform and the adult area be tested at 40 km/h with a 4.5 kg headform. This will be at impact angles of 50 and 65 degrees to the horizontal respectively. The proposed criterion is that for 75 percent of the child headform zone and 75 percent of the adult headform zone, the bonnet top test areas have a HIC 1250 and for the remaining 25 percent of the areas, it is recommended that the criterion be relaxed to HIC 2000.

A crush depth can be calculated based on the following assumptions:

- Manufacturers target is HIC 1000 or 1600, for the respective areas
- The bonnet top is at an angle ' θ ' to the horizontal
- The energy absorbed by the headform skin is small
- The energy efficiency of the vehicle structure that is crushed, i.e. the bonnet top, is 75 percent (a higher energy absorbing efficiency is assumed for the head because the HIC calculation is less sensitive to short excursions above the optimum than the other pedestrian criteria, which are all based on peak values)
- That the residual depth occupied by the crushed material is estimated at 5 mm (this will be variable across the headform test areas but should be approximately correct for the worst areas such as the wing edges).

The abrupt change between child and adult test areas in phase two of the Directive is intentional, because in practice this will result in a zone that is safe for the heads of both children and adults. However, as a result, additional crush depth will be required in the region of the 1500 mm Wrap Around Distance (WAD). If it is assumed that, because of this, the adult headform will have to be slowed using a stiffness appropriate for a child, then the maximum crush depth needed in this area can be estimated using the assumptions above and the ratio of adult to child headform mass i.e. 1.3. Because most structures tend to become progressively stiffer, the overall efficiency for the adult will be better than implied by these assumptions.

8.1.3.1 Landrover Freelander

These test requirements and assumptions can be used for the Landrover Freelander to find the required practical crush depths. For the Freelander, the angle θ is approximately equal to 5°. This gives a total crush depth for the adult headform of 82 mm for the HPC 1250 area and 61 mm for the HPC 2000 area. Likewise, for the child a total crush depth of 59 mm and 44 mm respectively can be calculated.

In the area near the 1500 WAD the estimated crush depth is likely to be about 85 mm for HPC 1250 and it is thought that the HPC 2000 relaxation will be just used for any small difficult areas in the child to adult transition zone.

8.1.3.2 Ford Mondeo

With the Ford Mondeo, the bonnet top angle, ' θ ,' is in the range of about 9° to 13° to the horizontal (11° was used for the calculation) at the front of the child area and in the range of 6° to 9° to the horizontal (7.5° used) at the rear in the adult area. Using the nominal bonnet angles of 11° for the child and 7.5° for the adult and the assumptions above, the practical crush depths required to meet the HIC criteria can be found for the Mondeo. This gives a total crush depth for the adult headform of

85 mm for the HPC 1250 area and 64 mm for the HPC 2000 area. Likewise, for the child a total crush depth of 69 mm and 52 mm respectively can be calculated.

In the area near the 1500 WAD the estimated crush depth is likely to be about 90 mm for HPC 1250 and it is thought that the HPC 2000 relaxation will be just used for any small difficult areas in the child to adult transition zone.

8.2 Protection features

Following the crush depth calculations, TRL's engineering judgment and experience was used to propose modifications that would make these vehicles meet the revised phase two Directive requirements. To make it possible to calculate the additional cost of pedestrian features, on the basis of including them into a total new vehicle design for the same vehicle segment with similar architecture, detailed specific solutions were proposed.

8.2.1 Landrover Freelander – modifications

The modifications required for the Landrover Freelander, in order to meet a revised version of phase two of the EC Directive, including the proposed changes (amendments made to reflect feasibility issues), are presented in the following sections. These modifications are broken down according to the pedestrian test which requires that modification.

8.2.1.1 Legform to bumper

For the legform tests, 62 mm of crush depth with energy absorbent material of the correct stiffness is needed to meet the performance criteria for this test, in particular the tibia acceleration. This is the value that was obtained from the crush depth calculation detailed above, in Section 8.1.1.

As described in Section 8.1.1, through the addition of a pedestrian friendly bumper 20 mm of existing crush space may be recovered. This is based on the contribution of the pedestrian friendly bumper towards the crush depth currently used to minimise costs for repairing bumper damage in low speed impacts, as assessed in bumper testing. Therefore the first modification is to reduce the crushable-box linkage, between the longitudinal chassis rails and the bumper face, by 20 mm in length. The effect of this on the bumper beam position is shown in Figure 8.2 with the old position shown in black and the new position dotted in red.



Figure 8.2. Bumper beam moved rearwards by 20 mm due to the reduction of the length of the collapsible box elements between the chassis rails and the bumper beam

The other 45 mm of crush depth required for the pedestrian legform test could be produced through movement of the bumper fascia forward by 45 mm. This is shown in Figure 8.3 with the new bumper fascia position shown by the red lines. As the bumper has little curvature when viewed from above, it should be easier to maintain a consistent gap between the bumper beam and the bumper fascia, however, any problem areas where the gap is small could be nominated for the relaxed test requirement.



Figure 8.3. Bumper fascia moved forwards by 45 mm

To control the energy attenuation of the legform impactor or pedestrian leg, an energy absorbing material is required between the bumper fascia and the bumper beam. On the Honda Jazz, this energy absorption potential is given by a collapsible U/box-section element on the front of the bumper beam, as shown in Figures 8.4 and 8.5. From these images the deformable section can be seen on the right. However, the crush initiation towards the edge does not extend along the entire section, which may present a problem with the initiation of the desired deformation. A better initiation solution may be developed along the lines of that shown in Figure 8.6. Alternatively, energy absorbing foam could be used between the bumper beam and the bumper fascia.

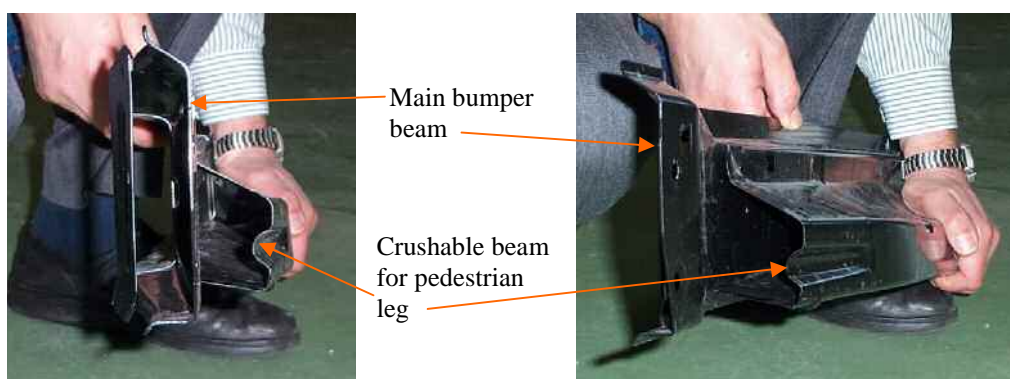

Figure 8.4. Honda Jazz bumper beam showing the section profile

Figure 8.5. Honda Jazz bumper beam oblique image

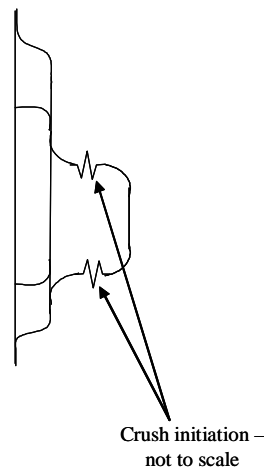

Figure 8.6. Revised bumper beam with improved crush initiation potential along the entire beam

Currently this vehicle has a high bumper and the above collapsible bumper beam solution, with sufficient crush depth, could be made to pass the high bumper upper legform test. However, the addition of a spoiler would lower the bumper and not only would this make it eligible for a legform test, but it would reduce the risk of knee injuries. In TRL's opinion the spoiler will also improve vehicle efficiency and stability by controlling the air-flow beneath the vehicle. Therefore, the more expensive option of a spoiler has been selected for the Freelander. The spoiler would be required to give a low load path for the legform impactor. However it would also impinge on the ramp angle required for off-road use; therefore a spoiler for on-road use will be fitted. This could be a pivoted or drop-down system, operated either manually, remotely or automatically, or a bolt-on system that could be removed before off-road use. For this costing exercise, the bolt-on option has been chosen. The new spoiler would bolt onto existing structures in the bumper and under-tray so that when removed, the vehicle would still have an effective bumper system for off-road use. The spoiler is shown by the red lines in Figure 8.7. The two points for attachment of this spoiler would be at the high most rearward point in the wheel arch (which would need a new fixing point) and at the front centre. This would be achieved by extending the top of the spoiler into the top of the existing lower air intake cavity in the bumper fascia and fixing the spoiler using the existing attachment screws (see Figure 8.8). The load path in the spoiler, for rigidity and for the protection for the legs of a pedestrian, needs to be of the correct stiffness. This rigidity may be gained through the use of a ribbed under-tray similar to that used in the Volvo S40 and shown in Figure 8.9. The ribbed under-tray will be fitted between the lower edge of the spoiler and the fixings of the existing engine splashguard or alternatively to new fixings in the sump-guard shown in Figure 8.10.

The protection for pedestrians that is offered with the introduction of a spoiler containing a low load path is only effective when the spoiler is fitted. For this reason it is desirable for the protection of pedestrians that the spoiler is always fitted when the vehicle is being used on the roads. However, some vehicle owners may prefer the look of their vehicle without the spoiler and not use it for all of the time they drive on roads. Therefore, it is essential that two things happen, firstly that vehicle owners are informed of the importance of the spoiler and secondly that manufacturers of a vehicle with a deployable or bolt-on spoiler are not held liable for any injuries to pedestrians should an accident occur where the spoiler was not fitted.

To re-assure vehicle manufacturers that they will not be held accountable for the actions of the vehicle owners, some expression stating this could be incorporated into the EC Directive relating to the protection of pedestrians and other vulnerable road users before and in the event of a collision with a motor vehicle.



Figure 8.7. New detachable bolt-on spoiler to provide low load path for the leg

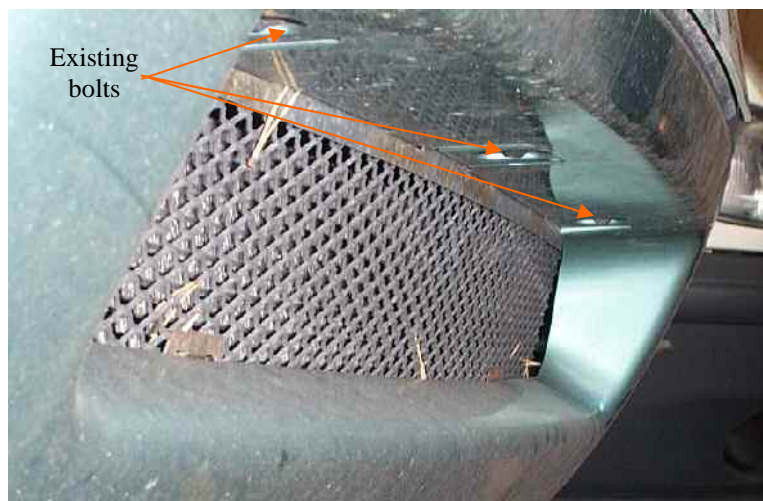

Figure 8.8. Top flange of the bolt-on spoiler would be fixed where marked (the air intake would be maintained in the new spoiler)



Figure 8.9. Ribbed under-tray and bumper fascia from the Volvo S40



Figure 8.10. Underside of Freelander showing metal and plastic bumper support where the new spoiler would be fixed

Following the introduction of the energy absorbing bumper beam and low spoiler load path, the stiffness of these elements would need to be tailored to give the optimum performance in the legform test. This optimisation process would be achieved initially using mathematical simulations of the components and then the integrated system, followed by some practical validation testing.

8.2.1.2 Upper legform to bonnet leading edge

For this vehicle it has been estimated that a total crush depth of 107 mm is needed to meet the more demanding upper legform criteria that are proposed for most of the BLE width. It has also been estimated from Euro NCAP upper legform test results that the current structure already has a crush depth of about 78 mm. For the upper legform tests to the bonnet leading edge, it is thought that by extending the bonnet forward by 45 mm to match the extended bumper, this additional crush depth, along with the crush depth already in the current vehicle, will provide sufficient depth to meet the more demanding upper legform criteria. Therefore the modifications in this area are re-designs of the existing elements to make full use of the crush space and to obtain the optimum stiffness. Any problem areas that cannot be made to meet this requirement could be nominated for the less demanding relaxation zone test.

The consequences of extending the leading edge of the bonnet (BLE) to match the extended bumper are shown in Figure 8.11. The matching is achieved by extension of the bonnet and wing and moving the headlamps forward to provide the same shape as before.

The extension of the bonnet, as shown in Figure 8.11, makes no fundamental change to the shape of the bonnet. However, to optimise the bonnet stiffness, it is also necessary to modify the underlying structure of the bonnet.

Figure 8.12 shows a schematic (lateral view) representation of the existing bonnet leading edge area in the Freelander. The proposed modifications to this area are shown in Figure 8.13. These modifications consist of the extension of the bonnet locking platform to match the extension of the vehicle as described above and the re-profiling of the bonnet reinforcing layer or inner skin, to follow the line of the outer skin more closely. This should make the bonnet edge more readily deformable. Associated with this is the required lengthening of the bonnet lock striker. Reducing the thickness of the front edge of the bonnet means that a taller bracket is required for the rubber seal on the bonnet to contact, however, as this will be in the child headform test area, a deformable, plastic or metal support has been used. The bonnet lock has also been moved back to remove it from the bonnet leading edge area and allow greater crush depth in front of it. As moving the current lock would require a pocket to

be made in the main box of the bonnet lock platform, which would have compromised its strength, the lock has instead been integrated into the cross-member by allowing the striker to pass through a tube in the box member to engage with a latch below. As the lock components beneath the cross-member are thin, it will not interfere with the cooling pack beneath. Again, as the bonnet striker will be in the child headform test area, it has been arranged so that it will not prevent the bonnet from deforming locally, as it can push through the lock and bend as necessary.



Figure 8.11. Bonnet leading edge changes following the bumper extension

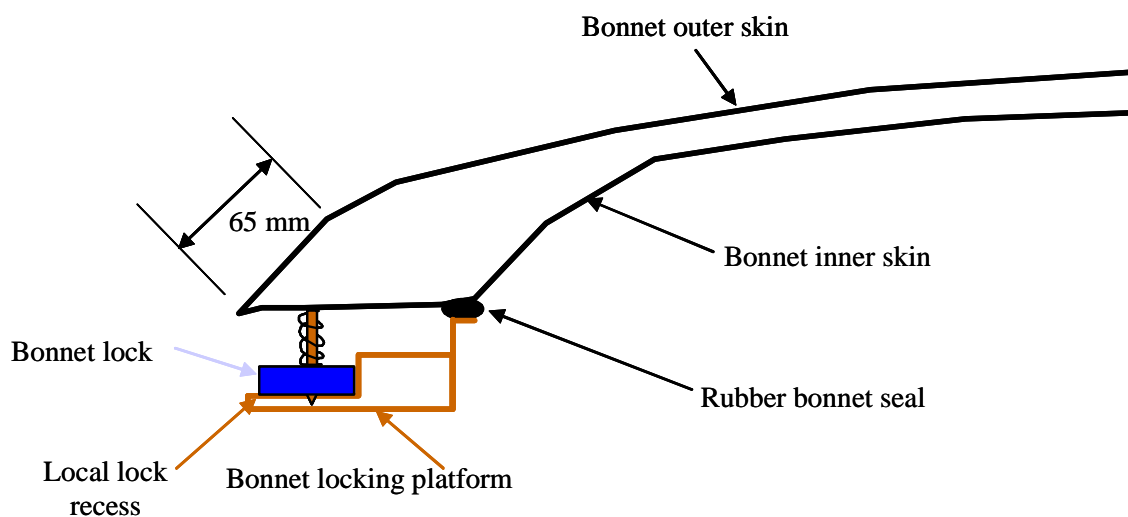

Figure 8.12. Existing bonnet reinforcement in the BLE region

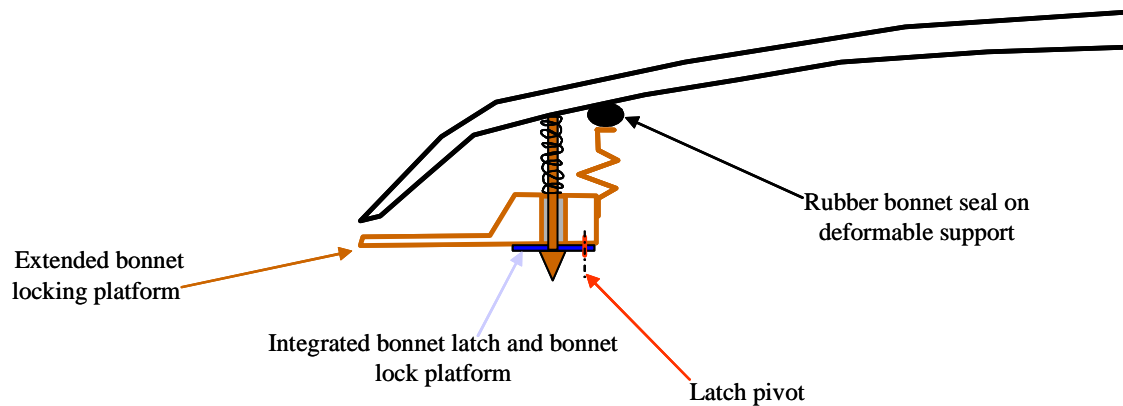

Figure 8.13. Bonnet reinforcement changes in the BLE region

As mentioned above, the headlamps need to be brought forward with the extended bumper. However, with this forward position, a further requirement of the protection for pedestrians in the bonnet leading edge region is for the headlamps to be deformable. Deformable headlamps with deformable lenses and reflector boxes are currently being developed to provide pedestrian protection and are already fitted to the Honda Civic and the new Volvo S40. As with most current vehicles, the headlamps will need to be tailor-made to match the styling requirements for the specific model although sharing of some components may be possible.

The changes for the bonnet leading edge proposed above will provide the crush space necessary to achieve the pedestrian protection requirements. However, a further stage of optimisation will be needed to obtain the optimum stiffness of these elements. This optimisation process would involve initial mathematical simulations of the components and then the integrated system, followed by some practical validation testing.

8.2.1.3 Headform to bonnet top

For the headform tests, there are four different requirements for crush depth that come from testing with both the adult and child headform impactors over the two regions of HPC requirements. By two regions of requirements, it is meant that the relaxation zone where the HPC must be less than 2000 is one area and the other is the area requiring the HPC to be less than 1250. For the bonnet test area of the Freelander, which is at approximately 5 degrees to the horizontal, the corresponding crush depths necessary to meet the requirements for these areas are, for the adult headform, 82 mm for the HPC 1250 area and 61 mm for the HPC 2000 area. Likewise, for the child, total minimum crush depths of 59 mm and 44 mm respectively can be calculated.

With the bonnet top, crush depth alone will not satisfy the requirements of the proposed phase two of the Directive. The stiffness and deformation of the bonnet is also critical. Therefore any assumption that the requirements can be met through the provision of adequate crush depth in the bonnet top also requires tailoring of the bonnet stiffness. The Freelander already has an aluminium bonnet which is likely to provide approximately the required pedestrian protection stiffness except where there are heavy reinforcements or underlying hard components. Therefore, for much of the bonnet area all that should be necessary is a revised, more homogenous bonnet under-frame. The revised under-frame will be refined and evaluated through the use of mathematical simulations, followed by full-scale validation tests.

The Freelander has a clamshell type bonnet, which covers the parts that normally constitute the wing edges. Taking into account the requirement to test a headform radius within the bonnet side reference line, for this vehicle the wing edges are outside or well beneath the tested surface. For wing edge child and adult headform tests, the impacts will be directed onto the edge of this clamshell bonnet. In

the child ‘wing edge’ area, the clamshell bonnet of the Freelander already has a crush depth starting at about 60 mm at the front and increasing to about 80 mm at the rear. For the adult, the available ‘wing edge’ clamshell bonnet crush depth starts at about 80 mm at the front and increases to about 100 mm at the rear of the wing.

It can be seen that the available crush depths are already sufficient to meet the more demanding HPC 1250 requirement along most of its length, once the stiffness of the structure has been optimised. For the more difficult child to adult transition area, use of the option to nominate for the less demanding HIC 2000 should also mean that no changes to the current styling and construction are needed to release more crush depth. Examination of the current bonnet edge structure also suggests that only minor changes will be required to optimise the stiffness. Therefore minimal changes are thought necessary to meet the more demanding protection requirements and any remaining problem areas could be nominated for the less demanding test.

Based on an examination of the vehicle, the support for the base of the windscreen is thought to consist of an extension of the firewall backed by a U shaped section to form a closed box cross-member, as shown in the ‘current’ diagrams in Figure 8.14. This type of closed box section is likely to be far too stiff for pedestrian protection, however, as this part is also an important cross-member, modifications for pedestrian protection should not reduce its strength in stiffening the structure. The solution adopted in the Honda Civic for pedestrian protection is to use a C-shaped cross member, as can be seen in Figure 8.15. To provide this type of solution in the Freelander, one of the sides of the box section has been removed as shown the ‘new’ diagrams in Figure 8.14. Due to the windcreens in both the Civic and the Freelander being curved, the shape of this C-shape section will need to progressively change from the centreline to the sides, to take account of this curvature. This curvature is accommodated in the Honda Civic C-section by changing the length of the top part of the C-section, as shown in Figure 8.15 and this is also included in the modifications for the Freelander, see Figure 8.14.

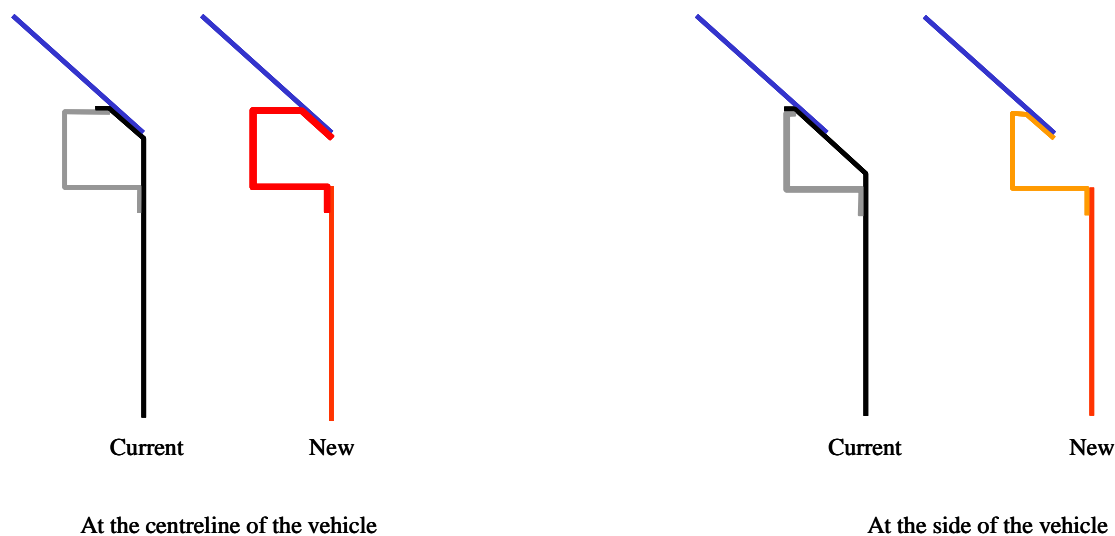

Figure 8.14. Schematic representation of the current and modified sections at the windscreen support

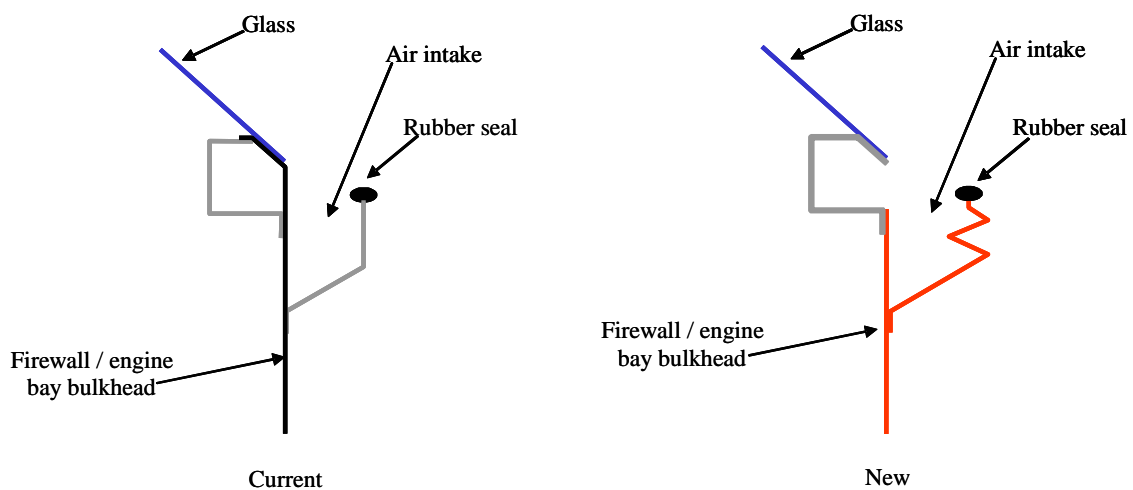

Figure 8.15. Honda Civic C-section of the upper bulkhead

Again some refinement of the design will be needed to tune the stiffness of the system using a combination of mathematical simulation and component testing and it is likely that some local stiffening of the C-section may be needed at the centre where the overhang is largest.

There are three problems for the protection of pedestrians in the windscreen scuttle area:

The first of these is the forward extension of the firewall to form the scuttle heater / ventilation air chamber. This comprises an angle section coming from the firewall with a rubber seal on the top, which supports the rear edge of the bonnet. To reduce the stiffness of this element, fold initiators in the form of corrugations will be added. Figure 8.16 shows a schematic representation of the current and modified structure.



At the centreline of the vehicle

Figure 8.16. Schematic representation of the current and modified sections for the extension of the firewall to form the scuttle heater / ventilation air chamber

The second of the issues for pedestrian protection in the windscreen scuttle area is the potential for contact with the wiper mechanism. At present the wiper mechanism operates from rigid linkages to the two spindles. These offer hard points for a pedestrian head impact. To make the wiper mechanism more pedestrian friendly, the linkages should be made to be frangible, as in the Honda Civic (Figure 8.17), so that they break off when impacted by the head of a pedestrian.



Figure 8.17. Honda Civic - frangible wiper spindle mounting following test (in place and removed)

It is interesting to note that since the Civic was produced, Honda has developed a more generic frangible system where the spindle bosses and frangible elements are combined. This approach means that these most expensive parts can be used unchanged across all or most of the Honda vehicle family with different low cost linkage arms, etc., see Figure 8.18. This approach means that the cost of wiper tooling can be spread across several models and not solely attributed to one model, as in the study of the Honda Civic by Lawrence *et al.* (2002).

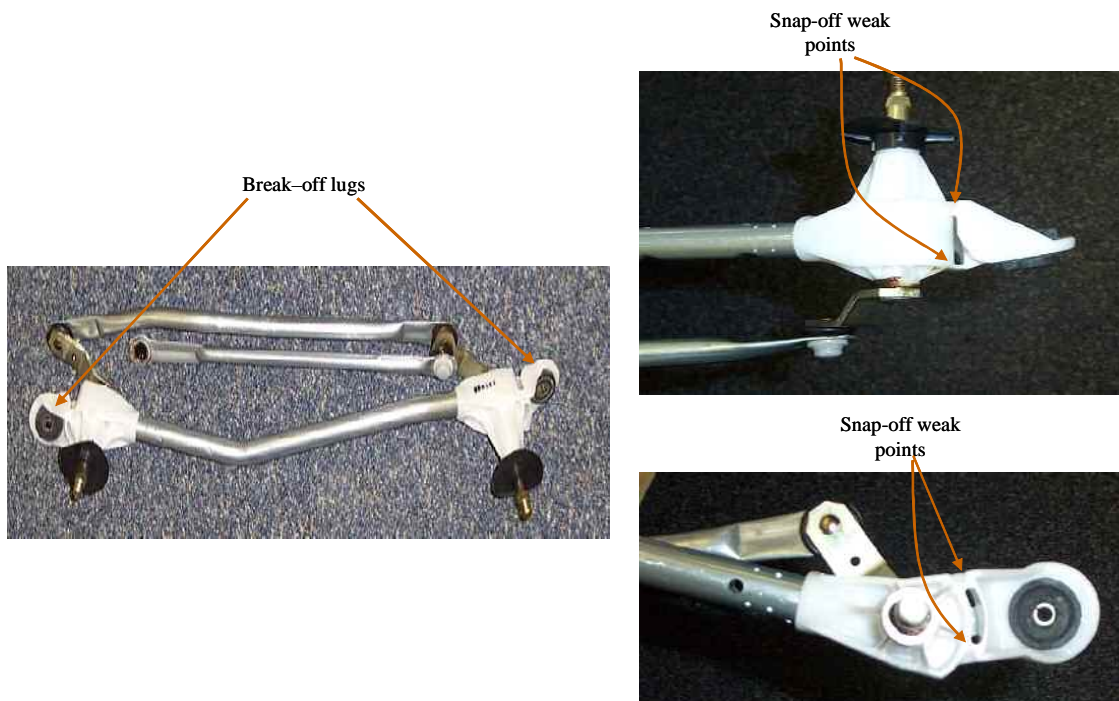

Figure 8.18. Honda Jazz pedestrian wiper system

An alternative to the frangible wiper system is to mount the wiper mechanism lower within the scuttle so that it cannot be contacted by the head. This solution can be seen in the latest VW Golf (Mk. V). However, the frangible solution will be used for this costing exercise.

The final problem points in this area are the hinges; however, as can be seen in Figure 8.19, the hinges themselves are well to the outside of the vehicle, approximately on the side reference lines. So, they will not be directly involved in a headform test as the test area starts one headform radius (82.5 mm) inside the reference line.

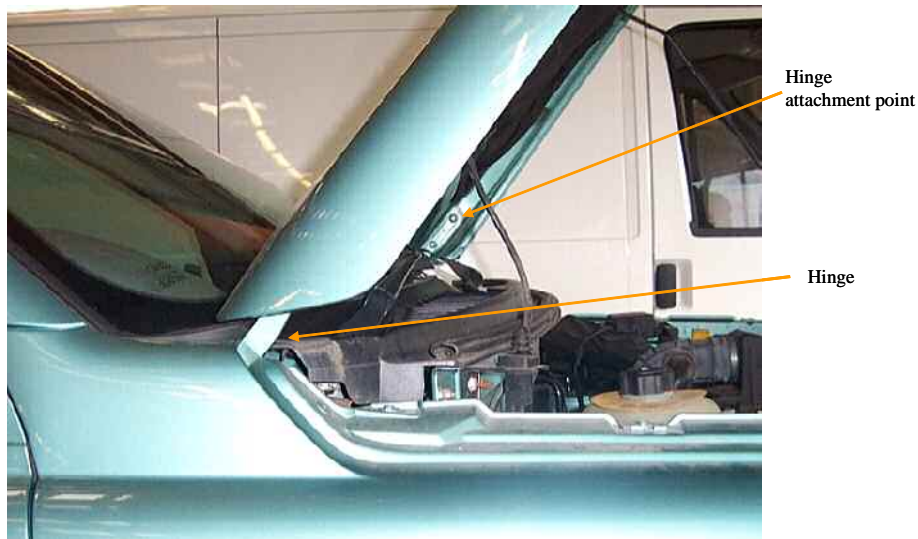

Figure 8.19. Bonnet hinge

Although the hinges will not be involved directly in a headform test they are likely to influence the crushing of the edge of the clamshell bonnet. Therefore, shear bolts will be used for the hinge attachment; these bolts will use a similar waisted design to that shown in Figure 8.20.



Figure 8.20. Necked shear screw - similar waisted design to be used for hinge bolt

Within the engine bay of the Freelander, the fluid reservoirs, the box containing the air filter, the fuse box and the engine top all represent high points. They are close enough to the bonnet that should a headform test be directed to the bonnet above one of these features, then the headform would interact with that feature (see Figure 8.21). At the moment these features or their mountings are too stiff to

gently decelerate a headform when impacted. Therefore, to achieve the required HIC value for such an impact, these features need to be moved or to be made less stiff. The clearances between these features and the underside of the bonnet were measured by closing the bonnet onto a pillar made from modelling clay, see Figure 8.21.



Figure 8.21. Measurements of Freelander's under bonnet crush space - V6 variant

The coolant reservoir is positioned above the McPherson strut on the right side of the engine bay, with a clearance to the bonnet of 10 mm. As the container is pressurised it is not thought feasible to make it crushable, so it will be moved to a new location in the engine bay. Although under-bonnet space is at a premium in the largest engine variant, it should be possible to find a new location where it can be mounted. Currently the reservoir appears to be mounted higher than is necessary for it to meet the requirement for it to be above the highest point in the cooling system, so it could be mounted lower to increase clearance. Alternatively a revised container and filler cap design could be used to achieve the same capacity in less height, either in the original or a new position.

The washer fluid reservoir is mounted close to the radiator in the front of the engine bay with a clearance to the bonnet of 30 mm from the top of the filler neck section. This filler neck will be made deformable by introducing a larger crank in the neck.

The brake and power steering fluid reservoirs are mounted at the rear and the right of the engine bay, respectively. To aid protection for pedestrians in a head impact, the attachment of the power steering reservoir to the engine bay structure will be made to be frangible, so that it will push down by using slotted or deformable mountings. For the brake fluid reservoir this will necessitate the replacement of the current rigid combined mounting and fluid connections to the brake master cylinder with flexible pipes along with a deformable or frangible mounting bracket. A similar arrangement to this was used for the brake fluid reservoir on the Honda Civic, see Figure 8.22.



Figure 8.22. Deformable brake fluid reservoir of the Honda Civic

The air filter in the Freelander is located on the left side of the engine bay and is contained within a box. The fuses are also located on the left and in some variants of the Freelander they are also contained within a box. The clearance from the top of these boxes to the bonnet is between 20 and 30 mm. To increase the protection for pedestrians in this area, both of these boxes should be made to be deformable by the use of fold initiators and, if necessary, revised plastic materials.

The clearance measured between the engine top cover and the bonnet underside was of the order of 35 mm and some deformation space is probably available in the cover and the under-bonnet sound proofing mat (for control of noise, vibration and harshness), which is likely to provide an additional 10 to 15 mm of crush depth. Therefore the crush available in this area is just sufficient to meet the HIC 2000 nominated requirement for the child but will be insufficient to meet the 61 mm required for the adult. For a new vehicle of this type some small saving in engine height and engine mounted height may be achievable. For a vehicle of this size it should be possible to arrange for the child to adult transition to be approximately in the area of maximum available clearance, in the gap between the bonnet locking platform and the highest points on the engine. This can be combined with adjustments to the bonnet curvature and engine height to create a zone with the necessary 85 mm clearance for the transition area. The scope for lowering the high engine parts is larger in this type of vehicle because it is mounted very high, but if necessary in addition or alternatively, the bonnet line towards the rear can be raised by about 15 to 20 mm to achieve the required clearance for the adult headform test. This should have no effect on the forward view angle for the driver, as the current view angle exceeds the angle of the bonnet to such an extent that the bonnet leading edge is the only part of the bonnet that interferes with view angles. However, for the purpose of this costing exercise, it will be assumed that, for a new vehicle, sufficient clearance will be achieved using a combination of a smaller more efficient engine and improved packaging.

8.2.2 Landrover Freelander – pedestrian impact cost implications

Modifications that are suggested as being necessary for the Landrover Freelander to meet the proposed requirements for phase two of the EC Directive are shown above in Section 8.2.1. In response to these modifications, Menard Engineering Limited first considered the feasibility of the TRL proposals and revised them where necessary using their specialised vehicle engineering experience. They then produced an estimate of the extra costs for pedestrian protection that would be incurred in producing a totally new vehicle of the same class and similar architecture. Although based

on the changes to the Freelander, they calculated costs for a more generic off-road vehicle. Therefore costs for parts have been calculated for more commonly used materials than are used in the Freelander.

The report on the Freelander, produced by Menard Engineering Limited, is presented below and has been unchanged by TRL Limited.



Freelander – Pedestrian Impact Cost Implications

26 April 2004

Contents

General Assumptions 3

The following cover areas of the vehicle Trim:-

- 1. Front Bumper Facia 3
- 2. Front Bumper Energy Absorbing Foam 3
- 3. Front Bumper Lower Spoiler 4
- 4. Front Undertray 5
- 5. Front Wiper System 6
- 6. Headlamps 6

The following cover areas of the vehicle for Body in White:-

- 7. Head Lamp bracket moved forward. 7
- 8. Pressed front Bumper Beam with initiators. 8
- 9. Front Spoiler rear fixing points. 8
- 10. Under Tray fixing rail. 9
- 11. Bonnet Outer Panel extended. 9
- 12. Bonnet Inner Panel extended. 10
- 13. Bracket Mounting for latch to Bonnet Inner. 10
- 14. Extension Support to Bonnet Locking Platform. 11
- 15. Modify Bonnet Latch and Bonnet Lock Platform – more latch rearwards. 11
- 16. Bracket support to mount rubber Bonnet seal. 12
- 17. Modify Front Fender Outers at front & rear top edge. 12
- 18. Modify Firewall Top section reinforcement to Base of screen. 13
- 19. Reinforcement Diaphragms added to reinforce the base of the Screen. 13
- 20. Modify Firewall / Engine bay Bulkhead – add crush zone. 14
- 21. Casting required to support Wiper Spindle and Mounts with crushable zones. 14
- 22. Bonnet Hinge fixed with breakaway bolts or bracket with crushable mounts. 15
- 23. Coolant reservoir to be relocated with crushable mounts 15
- 24. Brake & Fluid Reservoirs & pipes, reposition bracket with crushable mounts. 15
- 25. Air Filter and Fuse Box with crushable mounts – Remove engine cover. 16
- 26. Engine position – Engine mounts – Modifications required. [See Appendix B] 16

Summary of Costs 17

Appendix A - Consideration on Pedestrian Protection Legislation effects on Vehicle Design 18
 Appendix B - Engine reposition to a Landrover Freelander to improve pedestrian impact 20

General Assumptions

This report is based upon the TRL Report on the Landrover Freelander and the modifications required to meet a revised version of Phase 2 of the EC Directive on Pedestrian Protection. It assumes an estimated vehicle volume of 60000 per annum.

The On-Cost figures show the estimated cost effect of the Pedestrian Protection legislation on a New Vehicle Design (not for modifying an existing vehicle).

The costs exclude design and development.

1. Front Bumper Facia

Workscope

Front Bumper Facia depth increased by 45mm forward.

Notes

For this exercise it is assumed that the Front Bumper Facia will be a design based on the existing Freelander, using similar fixings, Fog Lamp, Grilles, etc. It will be a one piece painted Injection Moulded part using PC + PBT Blend material. The costs below are given for a full new Bumper Facia and the Pedestrian Impact On-Cost is for the additional tool size and part material due to the depth increase.

The Grilles, Fog Lamps, Parking Distance Sensors and Headlamp Wash Systems which can all be fixed to the Front Bumper System should also be considered with respect to Pedestrian Protection. The Mounting Designs for these items should be such that in an Impact they allow the movement of the items rearward or allow them to breakaway without leaving any sharp objects. The On-Cost for doing this to make them Pedestrian Impact friendly could be considered as minimal.

Facia Piece Part Costs

Front Bumper Assembly (excluding Fog Lamps) = £ 70

Pedestrian Impact On-Cost = £3

Facia Tooling Costs

Front Bumper Facia = £900,000

Pedestrian Impact On-Cost = £10000

2. Front Bumper Energy Absorbing Foam (Alternative to item 8)

Workscope

Front Bumper Energy Absorber.

Notes

Although some vehicles have Energy Absorbing material for Low Speed Impact requirements, for this exercise it is assumed that the Front Bumper System does not currently contain any Energy Absorbing material between the Bumper Beam and the Bumper Facia. There are various materials available such as Steel Pressed Beams (also costed in this study), Aluminium Honeycombs and EPP Moulded Foams. For this exercise we have chosen EPP Moulded Foam. The Density of the Foam will be in the region of 60g/l and this will be confirmed by Analysis to meet the requirements of both Low Speed and Pedestrian Impact requirements.

Note that although this could be considered as an On-cost for Pedestrian Impact the Energy Absorber could already be a requirement due to Low Speed Impact requirements and any tailoring to meet Pedestrian Impact will have minimal cost effect.

Foam Piece Part Costs
Front Bumper Foam = £10

Pedestrian Impact on Cost = £10

Foam Tooling Costs
Front Bumper Foam = £18000

Pedestrian Impact on Cost = £18000

3. Front Bumper Lower Spoiler

Workscope

Removable Front Bumper Lower Spoiler System. Bolted on the Bumper Facia and to the new ribbed Front Undertray.

Notes

This type of Front Bumper Lower Spoiler is of potential detriment to Off-Road driving therefore there is a requirement for the Spoiler to either be mechanically / electrically lowered and raised or to be able to be unbolted and removed by hand when going Off-Road. For this exercise the simpler option of the Spoiler been removed mechanically by hand for off-road use is to be considered.

(If a Spoiler System which can be raised and lowered mechanically or electrically is to be considered then the design study could be based on similar mechanisms for Rear Spoilers. However this will be a significant on cost)

There is an issue on non-replacement by the user when they return to on-road driving and possible liability. The use of an electronic sensor linked to a message on the Instrument Panel message display area which will inform the driver the Spoiler has been removed is a possible option which can be considered.

For this exercise the Spoiler is considered as an Injection Moulding (PC + PBT Blend) similar to the existing Bumper. It is also to be a painted finish.

The Spoiler will be designed to meet Aerodynamic and Cooling requirements with no detriments using analysis. It will also have to meet all Ground Clearance and Kerb Height requirements.

The Spoiler will incorporate apertures to give Air Flow access to the Lower Grille Area on the Main Bumper Facia.

The Upper Fixings will use existing fixing positions in Lower Grille Area and a new fixing in the Wheelarch area.

The Lower Fixings to be to the new Front Undertray.

The Spoiler could be considered as one Assembly with the new Front Undertray so can be removed as one unit.

Piece Part Costs
Front Bumper Lower Spoiler Moulding & fixings = £30.00

Pedestrian Impact On Cost = £30.00

Tooling Costs
Front Bumper Lower Spoiler Moulding = £300,000

Pedestrian Impact On Cost = £300,000

4. Front Undertray

Workscope

Ribbed Front Undertray supporting the Front Lower Spoiler.

Notes

For this exercise the Front Undertray will be an Injection Moulded (PP) part. Although for lower cost and on lower volume vehicles RRIM could be used.

The Fixings are to use existing available fixing positions for the Engine Splash Guard. Some additional Fixings may be required to give adequate support.

The Undertray will be fixed to the Front Lower Spoiler with J-Clips and Screws and could be considered as one Assembly with the Spoiler for ease of removal. When the Front Lower Spoiler is removed for Off-Road use then the Front Undertray will also have to be removed.

The Structural Rib pattern to Support the Spoiler will be designed with the aid of Analysis techniques.

The Undertray will also be designed to not be detrimental to the Cooling and Aerodynamic requirements with the aid of Analysis and Testing.

It should be noted that we are assuming that this Undertray is covering the Front Section of the Engine Bay only and is not considered as a Full Engine Bay Undertray.

It should also be noted that many new vehicles have Undertrays to meet NVH, Aerodynamic and Cooling requirements but for this exercise we are assuming that it is a new item fitted to support the Lower Spoiler, as on such an off road vehicle it is unlikely an Undertray will be in the required area. However if an Undertray is already a requirement for a new vehicle and is in the correct area to support the Spoiler then designing it to support the Spoiler should be achievable for a negligible On cost (A few additional fixings at an On-cost of £1.00)

Piece Part Costs

Undertray Moulding & Fixings = £6.50

Pedestrian Impact On Cost = £6.50

Tooling Costs

Undertray Moulding = £150,000

Pedestrian Impact On Cost = £150000

5. Front Wiper System

Workscope

Front Wiper System with breakaway Wiper Spindles

Notes

The Wiper System will be a Supplier Design and Development based on existing systems. Breakaway Wiper Spindles will be designed as part of the new Wiper System. It can be assumed that newly designed Wiper systems will incorporate this feature anyway and that to meet Pedestrian Impact a new car will use these new Wiper Systems, which may be used across a range of vehicles. The cost difference for these Wiper Systems will be minimal (depending upon volume) but for this exercise we will assume some on-cost to piece and tooling to cover their use as opposed to using a current carry-over system.

Costs for the breakaway mounts, piece and tooling prices see item 21 of this report.

Piece Part Costs

Front Wiper System (including motor) = £25

Pedestrian Impact On-Cost = £3.4

Tooling Costs

Front Wiper System = £170,000

Pedestrian Impact On-Cost = £25,500

6. Headlamps

Workscope

Headlamps designed as Pedestrian Impact friendly.

Notes

The Headlamps will be designed with breakaway mountings (part of the main moulding) and with deformable Polycarbonate lenses and reflector boxes.

Current design trend is to use polycarbonate lenses therefore there would be no requirement to change lens material for pedestrian impact legislation.

The deformable lamp structure would be accommodated by the design of flexible or breakaway mounting lugs/brackets. If this was identified as a requirement at the beginning of a project there would be negligible on-cost to the lamp.

However if a breakaway mounting system is adopted a repair kit would need to be designed and toolled. So the piece price and the tooling costs would be treated as after Market sales costs.

Piece Part Costs

Headlamp System = £35 (single pocket type) to £100 (Xenon type)

Pedestrian Impact On-Cost = £0

Tooling Costs

Headlamp System = £2.5 Million

Pedestrian Impact On-Cost = £0

Repair Kit Piece Part Costs
Repair Kit = £0

Pedestrian Impact On-Cost = £0

Repair Kit Tooling Costs
Repair Kit Tooling = £0

Pedestrian Impact On-Cost = £0

The following cover areas of the vehicle for Body in White :-

07. Head Lamp bracket moved foreword.

Workscope
Head Lamp bracket moved foreword by 45mm.

Notes

The head lamp one piece pressed steel panel would require all the fixing positions to have crushable mounts, the mount may need depressions with cut away portions into the steel work or dog legged fixing flanges, on impact the mounts would collapse giving a crushable zone area. The number of tooling operations would increase from three to four ops, for this exercise separate LH & RH tools sets.

This type of panel manufacture with deformable mounts would be required to support and hold a glass lens with a plastic headlamp casing, but as we are suggesting the use of a deformable Polycarbonate lens and reflector boxes, this steel head lamp panel costs are not required.

Piece Part	Costs LH & RH are + £ 0.00p
Press Tooling	Costs LH & RH are + £ 00,000
Assembly Tooling	Costs £ nil

The above costs do not take into consideration – Panel manufacturing feasibility, tool & assembly process modifications, Panel & Tool development programmes.

08. Pressed front Bumper Beam with initiators (Alternative to item 2)

Workscope

Bumper Beam to have pressed depressions.

Notes

Bumper Beam to have pressed depressions into the top and bottom panel surfaces to act as crush initiators; this will require three press tooling operations. This will be a new pressed steel panel and become an assembly with the current front beam; a new fixture is required to locate and spot weld the two together.

Pressed Piece Part	Costs one compt are + £ 3.28p
Press Tooling	Costs one compt are + £ 150,000
Assembly piece part	Costs one assy are + £ 1.12p
Assembly Tooling	Costs one fixture are + £ 13,370

The crush cans between the Main front Bumper beams are to reduce by 20mm to allow extra room for the beam, the savings on the piece price and the tooling costs for the inner and outer parts LH & RH are as follows:

Pressed Piece Part	Costs one compt are + £ 0.25p
Press Tooling	Costs one compt are + £ 8,500

The above costs do not take into consideration – Panel manufacturing feasibility, tool & assembly process modifications, Panel & Tool development programmes.

09. Front Spoiler rear fixing points.

Workscope

Front Spoiler sheet metal rear brackets.

Notes

New lower Spoiler to have two new rear brackets LH & RH to support the plastic assembly each side of the front fender, weld nuts to be assembled into the wheel house flange two per side. The steel brackets to be produced in three operations LH & RH together in a double pressed tool, the bracket to be bolted to the front fender through two weld nuts which have been projection welded into position, or alternatively welded to a nut plate which then is spot welded to the front fender.

A holding fixture and an upper electrode will be required to fix the weld nut to the fender or an extra clamp unit fitted to the front fender fixture, for this exercise the higher cost has been used.

Pressed Piece Part	Costs LH & RH are + £ 1.64p
Press Tooling	Costs LH & RH are + £ 70,000
Assembly piece part	Costs LH & RH are + £ 0.20p
Assembly Tooling	Costs one fixture are + £ 1,960

The above costs do not take into consideration – Panel manufacturing feasibility, tool & assembly process modifications, Panel & Tool development programmes.

10. Under Tray fixing rail.

Workscope

Fixing support rail required between under tray and engine splash guard.

Notes

New front spoiler will require rear support, the added under tray to be fixed to the front of the engine splash guard by a steel rail, this will provide sufficient stiffness to the front spoiler for front impact. The steel rail to be produced in three operations, this part will be bolted to the under tray for ease of front spoiler and under tray removal when Vehicle is in the off road mode, but spot welded to the engine splash guard.

A spot weld fixture is require to locate and clamp the two components together prior to spot welding taking place.

Pressed Piece Part	Costs one compt are + £ 1.19p
Press Tooling	Costs one compt are + £ 117,000
Assembly piece part	Costs one assy are + £ 0.50p
Assembly Tooling	Costs one fixture are + £ 6,982

The above costs do not take into consideration – Panel manufacturing feasibility, tool & assembly process modifications, Panel & Tool development programmes.

11. Bonnet Outer Panel extended.

Workscope

Bonnet outer panel extended by 45mm to match the front bumper position.

Notes

The front Bonnet outer panel area will extend foreword and therefore a percentage of 5% extra costs for the sheet steel and size of the pressed tooling set has been considered for this current exercise. The number of press tool - operations considered are four ops running in a 500 to 800 ton press, with auto sheet load and unload for the first press and manual load then auto unload for the parts there after.

The Hemming operation of the outer flange to the inner panel [the clinch flange] for this exercise to be performed on a free standing Hemming fixture, the fixture will increase in size, therefore a percentage of 2% extra costs for the final assembly has been considered for the current exercise.

The current Bonnet Outer panel material is manufactured from aluminium sheet, for this report we have given costs for steel component which could be the higher volume option for a new brand of Vehicle.

Pressed Piece Part	Costs one compt are + £ 0.40p
Press Tooling	Costs one compt are + £ 19,000
Assembly piece part	Costs one assy are + £ 0.30p
Assembly Tooling	Costs one fixture are + £ 4,900

The above costs do not take into consideration – Panel manufacturing feasibility, tool & assembly process modifications, Panel & Tool development programmes.

12. Bonnet Inner Panel extended.

Workscope

Bonnet inner panel extended by 45mm to match Bonnet outer and the front bumper position.

Notes

The front Bonnet inner panel area will extend foreword and therefore a percentage of 5% extra costs for the sheet steel and size of the pressed tooling set has been considered for this current exercise. The number of press tool - operations considered are three ops running in a 500 to 800 ton press, with auto sheet load and unload for the first press and manual load then auto unload for the parts there after.

The current Bonnet Inner panel material is manufactured from aluminium sheet, for this report we have given costs for steel component which could be the higher volume option for a new brand of Vehicle.

Pressed Piece Part	Costs one compt are + £ 0.34p
Press Tooling	Costs one compt are + £ 16,000
Assembly piece part	Costs are as above in section 11
Assembly Tooling	Costs are as above in section 11

The above costs do not take into consideration – Panel manufacturing feasibility, tool & assembly process modifications, Panel & Tool development programmes.

13. Bracket Mounting for latch to Bonnet Inner.

Workscope

The bracket mounting position of the Latch to the Bonnet locking platform must move rearwards,

Notes

The position of the Latch to the Bonnet locking platform must move rearwards, therefore a new steel support bracket produced in three operations will be required to secure the latch pin, weld nut, washer and the spring loaded collar to the Bonnet inner panel. The new bracket will be spot welded to the under side of the Bonnet inner panel, extra back ups, clamping and location pins will be required on the existing assembly fixture.

The above bracket is required due to the Bonnet inner panel front section being reduced in size to weaken it for frontal impact, allowing no room for securing the latch to the inner panel,

Pressed Piece Part	Costs one compt are + £ 0.85p
Press Tooling	Costs one compt are + £ 94,000
Assembly piece part	Costs one assy are + £ 0.29p
Assembly Tooling	Costs one fixture are + £ 3,815

The above costs do not take into consideration – Panel manufacturing feasibility, tool & assembly process modifications, Panel & Tool development programmes.

14. Extension Support to Bonnet Locking Platform.

Workscope

The Bonnet inner and outer panel have increased in depth by 45mm foreword, Bonnet platform upper part also to increase in length.

Notes

The Bonnet locking steel platform in this case consists of two components upper and lower parts, the upper part will extend foreword to support the increased length of the Bonnet assembly. For this exercise I have suggested that the platform will increase in width by 30%, therefore based on three press operations running in a 300 ton press, the piece and tooling prices have been calculated.

Pressed Piece Part	Costs one compt are + £ 0.80p
Press Tooling	Costs one compt are + £ 48,000
Assembly piece part	Costs one assy are + £ 0.15p
Assembly Tooling	Costs one fixture are + £ 1,225

The above costs do not take into consideration – Panel manufacturing feasibility, tool & assembly process modifications, Panel & Tool development programmes.

15. Modify Bonnet Latch and Bonnet Lock Platform – more latch rearwards.

Workscope

The Bonnet Latch assembly must move rearwards into the locking platform channel formed by the two components.

Notes

The latch assembly when mounted to the inner Bonnet panel must move rearwards, when the bonnet is closed the latch striker will enter a tube welded into the two piece Bonnet locking platform that will also contain the latch striker. The new steel latch pivot component will be produced in three operations running in a 100 ton press. The latch striker component to be located and clamped into the existing locking platform assembly fixture and spot welded into position.

Pressed Piece Part	Costs one compt are + £ 1.03p
Press Tooling	Costs one compt are + £ 51,000
Assembly piece part	Costs one assy are + £ 0.58p
Assembly Tooling	Costs one fixture are + £ 3,185

The above costs do not take into consideration – Panel manufacturing feasibility, tool & assembly process modifications, Panel & Tool development programmes.

16. Bracket support to mount rubber Bonnet seal.

Workscope

The Locking platform lower component to incorporate a crushable mount surface to fix the front Bonnet seal.

Notes

Due to the front Bonnet inner panel section reduction, the seal position is now higher in the Z plane, the lower locking platform to incorporate this vertical surface so that the Bonnet seal can be fixed to it.

It is assumed that the platform area will increase in size by 15%, therefore based on three press operations running in a 300 ton press, the piece and tooling prices have been calculated.

Pressed Piece Part	Costs one compt are + £ 0.33p
Press Tooling	Costs one compt are + £ 22,500
Assembly piece part	Costs £ nil
Assembly Tooling	Costs £ nil

The above costs do not take into consideration – Panel manufacturing feasibility, tool & assembly process modifications, Panel & Tool development programmes.

17. Modify Front Fender Outers at front & rear top edge.

Workscope

The front Fender LH & RH to move foreword to meet the new position of the headlamp and to increase in height at the rear to suit Bonnet level.

Notes

The increase in the front Fender costs for LH & RH components has been based on an increase of costs by 5% for each hand. For this exercise each front Fender Outer is produced on its own set of tools for each hand, that being six press operations per hand, running in a 1000 ton press, the piece and tooling prices have then been calculated.

The current Front Fender Inner panel is manufactured as a plastic component, for this report we have given costs for a steel component which could be the higher volume option for a new brand of Vehicle.

Pressed Piece Part	Costs two compt are + £ 0.54p
Press Tooling	Costs two compt are + £ 52,000
Assembly piece part	Costs £ nil
Assembly Tooling	Costs £ nil

The above costs do not take into consideration – Panel manufacturing feasibility, tool & assembly process modifications, Panel & Tool development programmes.

18. Modify Firewall Top section reinforcement to Base of screen.

Workscope

The firewall top section which forms the cross car box section at the base of the screen needs to be removed to form an open channel. This component is assumed to be a new part to a new product and has been costed that way.

Notes

The Firewall pressing is to be reduce in height in the Z plane to form an open section beneath the base of the front screen to give a crushable zone. For this exercise I have calculated a 10% reduction in panel area, and also include a tooling reduction. The panel tool process is based on four operations which take into account LHD & RHD components, and the steel panel to run in a 300 / 500 ton press. The piece and tooling prices have then been calculated.

Pressed Piece Part	Costs one compt are - £ 0.38p [this is a saving]
Press Tooling	Costs one compt are - £ 26,000 [this is a saving]
Assembly piece part	Costs £ nil
Assembly Tooling	Costs £ nil

The above costs do not take into consideration – Panel manufacturing feasibility, tool & assembly process modifications, Panel & Tool development programmes.

19. Reinforcement Diaphragms added to reinforce the base of the Screen.

Workscope

The reinforcement Diaphragms are to support the base of the front Screen and therefore will form part of the cross car box section complete assembly. This component is assumed to be a new part to a new product and has been costed that way.

Notes

These diaphragms have been added to give support to the base of the front screen, the new components will be produced in three operations and running in a 100 ton press. These parts will become part of the cross car box section complete assembly; it has been assumed the parts to be loaded into a hand applied fixture which will be loaded into the main cross car box assembly fixture and spot welded into position to complete the final assembled component.

A further assembly station may be required off line or bought in from a supplier, for this reason this cost has been left out.

Pressed Piece Part	Costs 3 - compts are + £ 2.47p
Press Tooling	Costs 3 - compts are + £ 65,000
Assembly piece part	Costs one assy are + £ 0.87p
Assembly Tooling	Costs one fixture are + £ 9,432

The above costs do not take into consideration – Panel manufacturing feasibility, tool & assembly process modifications, Panel & Tool development programmes.

20. Modify Firewall / Engine bay Bulkhead – add crush zone.

Workscope

The Engine bay Bulkhead to be modified by adding a crush zone into the front vertical face, the rear bonnet seal is fixed to this top surface.

Notes

This steel pressed component tooling operations would increase from three to four ops to produce the crushable zone in the vertical face, the press tools to run in a 300 ton press line. Any components welded to this surface may need to be repositioned, the changes to the surface should not affect the assembly of this part to the firewall assembly complete.

Pressed Piece Part	Costs one compt are + £ 0.28p
Press Tooling	Costs one compt are + £ 35,000
Assembly piece part	Costs £ nil
Assembly Tooling	Costs £ nil

The above costs do not take into consideration – Panel manufacturing feasibility, tool & assembly process modifications, Panel & Tool development programmes.

21. Casting required supporting Wiper Spindle and Mounts with crushable zones.

Workscope

The Wiper spindles and the mounting points to be manufactured from a suitable casting material with built in weak points to crush on impact for both LHD & RHD.

Notes

The Wiper spindle housing and its mounting lugs to the body in white nut weld plates, to have built in snap off weak areas designed within the casting basketry. This type of casting construction is required for both LHD & RHD positions, the manufacturing tooling costs could be spread across the range of variants for that make of Vehicle and types.

The assembly equipment required to connect all the wiper system components together should be no different to the existing production tools, therefore the on costs only cover the design & manufacturing tooling required to produce the LHD & RHD castings.

Pressed Piece Part	Costs two compt are + £ 4.08p
Press Tooling	Costs two compt are - £ 2,354 [this is a saving]
Assembly piece part	Costs £ nil
Assembly Tooling	Costs £ nil

The above costs do not take into consideration – Panel manufacturing feasibility, tool & assembly process modifications, Panel & Tool development programmes.

22. Bonnet Hinge fixed with breakaway bolts or bracket with crushable mounts.

Workscope

The Bonnet hinges to have built in crushable zones either breakaway bolts or deformable mounts to the Bonnet assembly.

Notes

The deformable mount route has been chosen for these costs, the upper half of the hinge steel leaf to be formed with crushable flange fixing points bolted to the Bonnet assembly.

This steel pressed component tooling operations would increase from two to three ops to produce the crushable zone in the vertical face; the press tools would produce LH & RH parts together and run in a 300 to 500 ton press. The assembly of the two half leaves with the changed form should not alter the production process at the supplies for the completed hinge.

Pressed Piece Part	Costs two compt are + £ 1.30p
Press Tooling	Costs two compt are + £ 24,000
Assembly piece part	Costs £ nil
Assembly Tooling	Costs £ nil

The above costs do not take into consideration – Panel manufacturing feasibility, tool & assembly process modifications, Panel & Tool development programmes.

23. Coolant reservoir to be relocated with crushable mounts

Workscope

Coolant reservoir container to be lowered repositioned and redesigned with crushable mounts.

Notes

This steel pressed component tooling operations would increase from two to three ops to produce the crushable mount zones, the press tools would run in a 100 ton press. The assembly cost of the bracket to the body in white will not alter but the production process would, for this exercise I have not included these costs as out lined below

Pressed Piece Part	Costs one compt are + £ 0.25p
Press Tooling	Costs one compt are + £ 20,000
Assembly piece part	Costs £ nil
Assembly Tooling	Costs £ nil

The above costs do not take into consideration – Panel manufacturing feasibility, tool & assembly process modifications, Panel & Tool development programmes.

24. Brake & Fluid Reservoirs & pipes, reposition bracket with crushable mounts.

Workscope

Brake & Fluid Reservoir container to be lowered repositioned and redesigned with crushable mounts.

Notes

The steel pressed component tooling operations would increase from two to three ops to produce the crushable mount zones, the press tools would run in a 100 ton press. The assembly cost of the bracket to the body in white will not alter but the production process would hence, no costs added for this.

Pressed Piece Part	Costs one compt are + £ 0.25p
Press Tooling	Costs one compt are + £ 22,000
Assembly piece part	Costs £ nil
Assembly Tooling	Costs £ nil

The above costs do not take into consideration – Panel manufacturing feasibility, tool & assembly process modifications, Panel & Tool development programmes.

25. Air Filter and Fuse Box with crushable mounts – Remove engine cover.

Workscope

Air Filter and Fuse Box containers to be lowered repositioned and redesigned with crushable mounts.

Notes

These steel pressed component tooling operations would increase from two to three ops to produce the crushable mount zones, the press tools would run in a 100 ton press. The assembly costs for these brackets to the body in white will not alter but the production process would, for this exercise I have not included these costs as out lined below.

This crushable brackets would not be required if the Air Filter and Fuse Box plastic components where manufactured using a softer material and incorporated collapsible mounts in the plastic component, on impact this type of construction would deform out of the way. Therefore we can remove this piece price and tooling costs from the report.

Air Filter steel bracket

Pressed Piece Part	Costs one compt are + £ 0.00p
Press Tooling	Costs one compt are + £ 00,000
Assembly piece part	Costs £ nil
Assembly Tooling	Costs £ nil

Fuse box steel bracket

Pressed Piece Part	Costs one compt are + £ 0.00p
Press Tooling	Costs one compt are + £ 00,000
Assembly piece part	Costs £ nil
Assembly Tooling	Costs £ nil

The above costs do not take into consideration – Panel manufacturing feasibility, tool & assembly process modifications, Panel & Tool development programmes.

26. Engine position – Engine mounts – Modifications required. [See Appendix B]

Workscope

The Engine bay package would require a great deal of re – engineering, this will effect Panel and assembly tooling Manufacturing production line processes and development costing. For this exercise, please refer Appendix B, as this is not in the scope of work for this report, but appendix B outlines the considerations if the engine is to be repositioned.

The costs for raising the bonnet are included in the bonnet and fender costs (items 11, 12, 17).

Summary of Costs

Ref no	Report Section	Part Description	New Items	Compt & Assy Tool type	Additional Manufacture piece cost / Vehicle	Additional Tooling / Assy costs per Programme	
1	FIGURE 2.0	FRONT BUMPER FACIA INCREASE DEPTH BY 45mm.		plastic	£3.00 £0.00	£10,000.00 £0.00	
2	FIGURE 2.0	FRONT BUMPER ENERGY ABSORBING FOAM MATERIAL FOR LOW SPEED IMPACT	#	foam	£10.00 £0.00	£18,000.00 £0.00	
3	FIGURE 2.0	FRONT BUMPER LOWER SPOILER REMOVABLE SPOILER BOLTED TO BUMPER FACIA	#	plastic	£30.00 £0.00	£300,000.00 £0.00	
4	FIGURE 9.0	FRONT UNDERTRAY UNDER TRAY TO SUPPORT FRONT LOWER SPOILER	#	plastic	£6.50 £0.00	£150,000.00 £0.00	
5	FIGURE 16 FIGURE 17	FRONT WIPER SYSTEM WITH BREAK AWAY WIPER SPINDLES AND FIXINGS		steel	£3.40 £0.00	£25,500.00 £0.00	
6	FIGURE 2.0	HEADLAMPS - DESIGNED AS PEDESTRIAN IMPACT FRIENDLY REPAIR KIT WILL BE REQUIRED - NO COSTS FOR THIS REPORT	#	plastic plastic	£0.00 £0.00	£0.00 £0.00	
7	FIGURE 2.0	FRONT HEAD LAMP - MOVED FORWARD - NO COSTS FOR THIS REPORT - AFTER SALES. HEAD LAMP BRKT MODIFIED WITH CRUSHABLE FIXINGS-REQUIRED IF CLASS LENS ISUSED		pressed assy	£0.00 £0.00	£0.00 £0.00	
8	FIGURE 5.0 FIGURE 1.0	PRESSED FRONT BUMPER BEAM - ADD CRUSH INITIATION DEPRESSIONS. ADD FORM TOOL TO PRESS IN THE DEPRESSIONS. MAIN BUMPER BEAM MOVES REARTWARDS BY 20mm - CRASH CANS REDUCE BY 20mm	#	pressed assy pressed	£3.28 £1.12 -£0.25	£150,000.00 £13,370.00 -£8,500.00	
9	FIGURE 2.0	FRONT SPOILER REAR FIXING POINTS LH / RH. SHEET METAL BRACKET X 2	#	pressed assy	£1.64 £0.20	£70,000.00 £1,960.00	
10	FIGURE 9.0	UNDER TRAY FIXING RAIL TO ENGINE SPLASH GUARD TO GIVE SUPPORT TO UNDER TRAY & SPOILER.	#	pressed assy	£1.19 £0.50	£117,000.00 £6,982.00	
11	FIGURE 10	BONNET OUTER PANEL - [SHEET METAL PRESSING] EXTENDED 45mm FORWARD		pressed assy	£0.40 £0.30	£19,000.00 £4,900.00	
12	FIGURE 11	BONNET INNER PANEL - [SHEET METAL PRESSING] EXTENDED 45mm FORWARD WITH REDUCED FRONT BOX SECTION (see ref 11)		pressed assy	£0.34 £0.00	£16,000.00 £0.00	
13	FIGURE 12	BRACKET MOUNTING TO BONNET INNER - BONNET LATCH LOCKING LOCAL BRACKET TO SUPPORT BONNET LATCH WITH REINF PLATE AND NUT	#	pressed assy	£0.85 £0.29	£94,000.00 £3,815.00	
14	FIGURE 12	EXTENSION SUPPORT TO BONNET LOCKING PLATFORM SHEET METAL FORMED PLATE ADDED LENGTH.		pressed assy	£0.80 £0.15	£48,000.00 £1,225.00	
15	FIGURE 12	MODIFY BONNET LATCH AND BONNET LOCK PLATFORM REPOSITION LATCH REARWARD - ADD TUBE AND LATCH PIVOT	#	pressed assy	£1.03 £0.58	£51,000.00 £3,185.00	
16	FIGURE 12	BRACKET SUPPORT TO MOUNT RUBBER BONNET SEAL SHEET METAL DEFORMABLE SUPPORT - WIDTH OF CAR		pressed assy	£0.33 £0.00	£22,500.00 £0.00	
17	1.13.1	MODIFY FRONT FENDER OUTERS LH & RH. REPOSITION FRONT EDGE TO HEAD LAMP - INCREASE HEIGHT AT REAR TOP SURFACE.		pressed assy	£0.54 £0.00	£52,000.00 £0.00	
18	FIGURE 13	MODIFY FIREWALL TOP SECTION REINF TO BASE OF SCREEN. THE TOP SECTION OF THE PANEL TO B E REMOVED.		pressed assy	-£0.38 £0.00	-£26,000.00 £0.00	
19	FIGURE 14	REINF DIAPHRAGMS ADDED TO REINF TO BASE OF SCREEN - 3 OFF DIAPHRAGMS TO BE ADDED TO THE REINF ASSY TO SUPPORT CENTRE BASE SCREEN.	#	pressed assy	£2.47 £0.87	£65,000.00 £9,432.00	
20	FIGURE 15	MODIFY FIREWALL / ENGINE BAY BULKHEAD, ADD SWAGE FORM TOOL SWAGES TO BE ADDED TO FORM CRUSH ZONE.		pressed assy	£0.28 £0.00	£35,000.00 £0.00	
21	FIGURE 16 FIGURE 17	CASTING REQUIRED TO HOUSE WIPER SPINDLE - BREAK AWAY SPINDLES & MOUNTS. FIXING BRACKETS TO BODY - CRUSHABLE FIXING POINTS, LH & RH.		pressed assy	£4.08 £0.00	-£2,354.00 £0.00	
22	FIGURE 18 FIGURE 19	BONNET HINGE - TO BE FIXED WITH BREAK AWAY BOLTS - SHEAR BOLTS SPECIALS. NEW BRKT MOUNT HINGE FIXING TO BONNET WITH CRUSHABLE INITIATORS.		pressed assy	£1.30 £0.00	£24,000.00 £0.00	
23	1.13.4	COOLANT RESERVOIR TO BE RELOCATED NEW BRACKET REQUIRED WITH CRUSHABLE INITIATORS.		pressed assy	£0.25 £0.00	£20,000.00 £0.00	
24	1.13.4	BRAKE & FLUID RESERVOIRS & PIPES - CRUSHABLE BRAKE RESVR BRKT. FLUID RESERVOIRS & PIPES - CRUSHABLE FLUID RESVR BRKT.		pressed assy	£0.25 £0.00	£22,000.00 £0.00	
25	1.13.4	AIR FILTER , CRUSHABLE PLASTIC HOUSING - ENGINE TOP COVER TO BE REMOVED. FUSE BOX - CRUSHABLE PLASTIC HOUSING - NO COSTS FOR THIS REPORT.		plastic plastic	£0.00 £0.00	£0.00 £0.00	
26	1.13.4	ENGINE POSITION - ENGINE MOUNT - MODIFICATIONS. [SEE DOCUMENT] OR RAISE BONNET 15 TO 20mm.					
					TOTAL COSTS	£71.16	£1,162,145
					TOTAL COSTS	£65.31	£1,299,015
					Piece costs per Vehicle		Added Tooling per Programme

2 (With foam bumper)
8 (With pressed Beam)

The above tooling costs can be spread over the model life (7 Years), hence divide the above by the number of years.

Notes for Consideration on Pedestrian Protection Legislation effects on Vehicle Design

To compliment the Piece and Tooling Costs details the following notes on the effects of Pedestrian Protection Legislation on Vehicle Design should also be considered. It should also be noted that the Piece and Tooling Costs do not include any Costings for any additional Design, Analysis and Testing.

Weight – Weight increases will occur due to additional components, deeper bumper, Lower Spoiler, higher Bonnet and longer vehicles. Any weight increase will have a negative effect on Emissions and Fuel Consumption Performance, as noted below.

Styling – Affects the Front End style on hood, bumpers, etc. Any concern that it will give a “chunkier” feel to vehicles and all will look similar is not really the case as Honda has successfully achieved the requirements with well styled vehicles that meet the current requirements. Vehicles will also be longer and have higher front ends but a capable design team should be able to accommodate this within any new style.

Package – It could be difficult to package Engines to give additional clearances (see attached notes). But designing systems as Pedestrian Impact friendly should be achievable especially working with the Supplier base. Forward vision Angle, Front Approach Angle, Kerb Strike Requirements, Airflow and Cooling performance can all be affected to their detriment.

Aerodynamics – The requirements to have a flatter Front end form will effect the Aerodynamic performance and potentially effect emissions, fuel consumption performance and vehicle NVH. The effects would be studied using CAE analysis and any issues resolved during the design process.

Emissions and Fuel Consumption – The combination of the weight increases and the Aerodynamic effects will have a negative impact on the vehicle's Emissions and Fuel Consumption Performance, which may require modifications to the Engine and Powertrain Systems. Furthermore, these changes are likely to have an effect on Vehicle Performance, Ride and Handling, High Speed Stability, Steering and Braking. Another issue to consider is the issue of effectively a softer Front end on the Airbag Sensor Calibration. The Calibration will need to take this into consideration.

Durability, Reparability and Serviceability (Insurance Ratings) – The requirement for breakaway or deformable Parts and Systems effectively weakens them. This will have a knock-on effect to the Vehicle Durability, its reparability (Thatcham) and its serviceability. Accurate Analysis for these items will be necessary to develop a compromise solution between all vehicle requirements.

Vehicle Target Setting – As stated the requirements for Pedestrian Protection legislation can affect various areas of the Vehicle Attributes. When the vehicle targets are set at the beginning of the program consideration should be given to this.

Material Selection – When materials are selected Pedestrian Protection requirements should be considered. The use of new Energy Absorbing materials will be considered in the future to aid in meeting the requirements (e.g., Pedestrian Protection Shock Absorbing Liquid Packages, etc)

Fixing Selection – When Fixings are selected Pedestrian Protection requirements should be considered. Also the position and direction of the Fixings can be designed at an early stage to have no detrimental effects. (e.g., do not have any hardpoints or sharp points facing in a forward or upward direction)

Manufacturing Feasibility – The theory of solutions to meet the requirements should be backed up with approval from the OEM and Supplier Manufacturing Engineers. Often Panel Design, stampings and assembly Production tooling Manufacturing and Production on line and off line process methods are limited, (due to many factors) and may not be able to manufacture or assemble the required designs.

Additional Engineering Design Work – In theory there should be limited additional Engineering Design as these parts and Systems will be designed anyway on a new vehicle. However it should be considered that most “new” vehicles contain a large percentage of Carry-Over Parts and Systems. These Carry-Over items, if they effect Pedestrian Protection requirements, will have to be redesigned and replaced. The phasing in period for the legislation should allow for this. The Pedestrian Protection requirements should be considered and designed for during the early stages of the Design process. The use of Deformable or Breakaway systems may cause some additional work but examples of these systems are available to use as a basis for any new Designs.

Any parts that have to be redesigned to meet the legislation can potentially be carried over to use on other vehicles which will ultimately reduce their piece costs (but could increase the tooling cost due to the volume increase). It is very difficult to adjust the figures to reflect this without more detailed involvement in the actual designs and knowing what vehicle ranges are involved. However likely candidates to be able to be carried over are brackets, wiper system, headlights (styling permitting) and Underbody BIW. Therefore for this report we can make a statement by advising a percentage decrease in costs by some 15% for the wipers and the headlamp piece prices and tooling costs. These costs have been reduced in this report.

Additional Analysis Work – In theory the only additional Analysis work required is for Pedestrian Impact. Aerodynamic, Cooling and Vehicle Crash Testing will be done anyway on a new vehicle although some additional iterations may be required if the Pedestrian Impact requirements cause any changes.

Additional Test Work – In theory the only additional Test work required is for Pedestrian Impact. Aerodynamic, Cooling and Vehicle Crash Testing will be done anyway on a new vehicle although some additional iterations may be required if the Pedestrian Impact requirements cause any changes.

Active Pedestrian Impact Systems – If it is found that a new vehicle design cannot be packaged to give sufficient Engine Clearance to the Bonnet then an Active Pedestrian Impact System can be considered. This can take the form of the new developments in Pop-up Bonnets, which raise in the event of an impact with a Pedestrian to give additional clearance, or external Airbags. These systems are complimented with additional Sensors on the front of the vehicle to determine a Pedestrian Impact is taking place before activating the systems.

However these systems are new developments and will add significant cost and weight to a vehicle. So they are likely to only be considered in the higher vehicle specification ranges where the cost can be absorbed and where for package reasons the legislation cannot be met within the vehicle design.

Appendix B

Engine reposition to a Landrover Freelander to improve pedestrian impact.

The ACEA recommendation is to provide impact absorption to 65mm depth.

The WG17 recommendation is to provide impact absorption of 95mm depth.

Currently the engine has 35mm clear to the top of the engine acoustic cover.

Assuming this can be removed or is flexible to 15mm, an additional 15 – 20mm of clearance is desired to achieve compliance to the ACEA standard.

The following considerations will be applicable to re-positioning the engine:-

- Re-package engine & transmission assy to achieve desired top end clearance.
- Check ground clearance line (GCL) has not been encroached upon or exceeded.
- Sump reprofiling can improve ground clearance, but only in consideration of oil capacity, oil pick-up design change and consideration to serviceability for oil drain.
- New position of engine to be checked for clash conditions to engine bay, specifically the cooling pack and fan shrouds, as Front End Accessory Drive (FEAD) parts would assume a new location.
- All hoses: Cooling, Air system, Heater/ HVAC, Exhaust Gas Recirculation (EGR) & vacuum supply to servo, would need to be re-designed to the new package position.
- Fuel supply pipes will need to be redesigned.
- Engine mounts would need to be redesigned. Could impact on Torque Roll Axis (TRA) requiring full FEA work.
- Driveshaft angles / lengths would change, requiring redesign.
- Transmission and/or clutch bell housing may encroach on GCL preventing decking to desired limit, but some work on the bell housing may be possible.
- Clutch and transmission control linkages will need redesigning.
- Reservoirs for coolant, PAS, brakes and clutch may need work to permit flexibility in the event of impact.
- Fuel filter may need to be repositioned.
- Crankcase ventilation system piping will need redesigning.
- Carbon canister piping will need to be redesigned.
- Dip-stick may need to be lengthened after decking to improve serviceability.
- Check for FEAD serviceability with engine in new position. (Tooling access for belt removal & tensioning).
- Engine harness main connection may need lengthening.
- Exhaust downpipe change to accommodate reposition of engine. If close coupled Cat, Cat position and heat-shielding change may be required.
- If turbo is fitted. Ensure no temperature sensitive components are compromised. Adequate heat shielding may need to be repositioned / designed.
- If undertray is fitted, modifications may need to be made to provide clearance.

8.2.3 Ford Mondeo – modifications

The modifications required for a new large family car, based on inspection of the Ford Mondeo, in order to meet a revised version of phase two of the EC Directive including the proposed changes (amendments made to reflect feasibility issues), are presented in the following sections. These modifications are broken down according to the pedestrian test which requires that modification.

8.2.3.1 Legform to bumper

For the legform tests, there are two different requirements for crush depth that come from the two performance widths. The first is a region for all but 264 mm of the bumper test width that must meet the more demanding requirement that the tibia acceleration be no more than 190 g. The second is a relaxation zone for which up to 264 mm of the test width can be nominated by the manufacturers to meet the less demanding requirement for the tibia acceleration to be no more than 250 g. The corresponding crush depths necessary to meet the requirements for these widths are, for the 190 g width, 62 mm and, for the 250 g nominated relaxation zone, 45 mm. These minimum crush depths include an allowance of 10 percent for the residual depth occupied by the crushed material.

Through the addition of a pedestrian friendly bumper, 20 mm of existing crush space may be recovered from the low-speed impact energy management system. This is based on the contribution of the pedestrian friendly bumper towards the crush depth currently used to minimise costs for repairing bumper damage in low-speed impacts, as assessed in bumper testing. However, insurance ratings are important on a volume vehicle of this type, so it was decided to recover only 14 mm from the existing crush space. Therefore the first modification is to reduce the energy absorbing crush cans of the bumper beam, see Figure 8.23, which connect to the longitudinal chassis rails, by 14 mm in length. The effect of this on the bumper beam position is shown in Figure 8.24 with the old position shown in blue and the new position in red.

The bumper beam in the Ford Mondeo does not follow the outer skin profile of the bumper fascia. The clearance between the outer fascia and the bumper beam is greatest in the middle of the vehicle and smallest towards the ends of the bumper beam (see Figure 8.23 for the bumper beam). At the point of minimum clearance between the fascia and the beam, there is approximately 20 mm separation. Therefore, in addition to the 14 mm crush depth gained through the rearward movement of the bumper beam, as shown in Figure 8.24, there is at least a further 20 mm available, making a total of 34 mm. Therefore a further 28 mm needs to be created to meet the required 62 mm crush depth for the protection of pedestrians to the 190 g criterion and a further 11 mm to meet the required 45 mm of crush depth for the relaxation zone.

It is known that this 'Hydro-form' beam is expensive to make so it is proposed that a more conventional steel or aluminium beam is used. However, as hydro-formed beams are unusual, no allowance will be made for any saving found by using a more conventional beam, when calculating costs for pedestrian protection.

To create the remaining 28 mm of crush depth required for the pedestrian legform test, the bumper fascia will be moved forward. The amount by which the bumper fascia needs to be moved forward is not immediately obvious as the curvature of the bumper beam is not known exactly. This curvature needs to be considered with respect to the quantity of the bumper surface that would be contained within the relaxation zone, the area where the reduced performance tibia acceleration criterion of 250 g must be met. It is anticipated that as the centre of the bumper beam would already pass the more stringent area requirements (with the correct crush stiffness) and as the worst area needs only a further 11 mm of crush depth to pass the reduced criterion, then the bumper may only need to be moved forward by about 15 mm. Therefore for this exercise, the increase in length required to give the necessary protection for pedestrians, and pass the revised criteria proposed for phase two of the EC Directive, shall be set to 15 mm. Due to the difficulty in accurately displaying this small change in vehicle length, it has not been included as a separate figure.

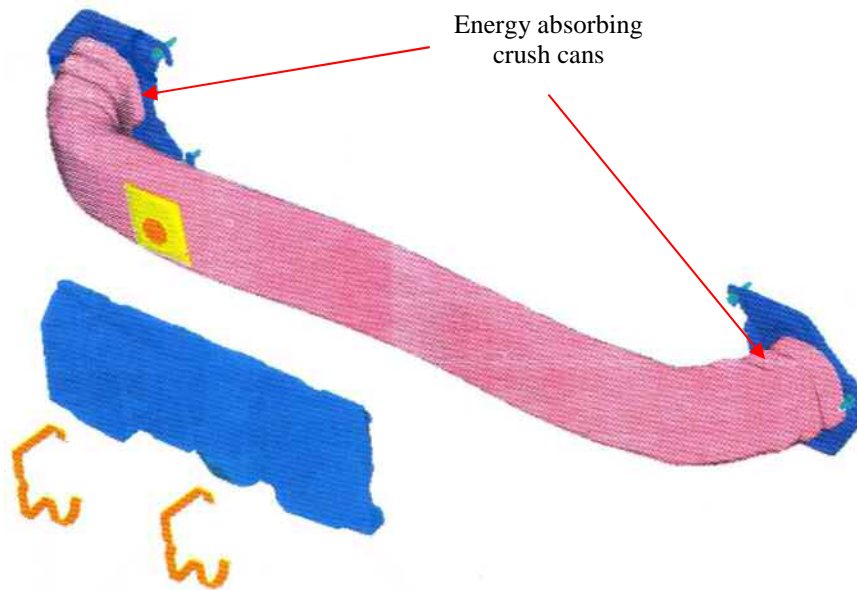

Figure 8.23. Mondeo bumper beam and clip-on energy absorbing foam



Figure 8.24. Bumper beam moved rearwards by 14 mm due to the reduction of the length of the energy absorbing crush cans of the bumper beam used to link to the chassis rails

As mentioned with the Landrover Freelander, to control the energy attenuation of the legform impactor or pedestrian leg, an energy absorbing material is required between the bumper fascia and the bumper beam. The solution proposed for this feature is the same as that for the Freelander (see Figure 8.6). This is based on the bumper beam used in the Honda Jazz, as shown in Figures 8.4 and 8.5.

The bumper is required to give a low load path for the legform impactor. This is required at the same forward position as the bumper leading edge. Figure 8.25 shows a revised bumper (shown in red) based on the existing shape but with the bumper 15 mm forward as suggested above and with the lower edges brought even further forward to provide a low load path. As the ramp angle of modern cars can be considered to be critical, the extension of the bumper lower edge has been moved forward and upward to maintain the current ramp angle of about 16° (the approximate line from which the ramp angle is derived is shown in orange in Figure 8.25).

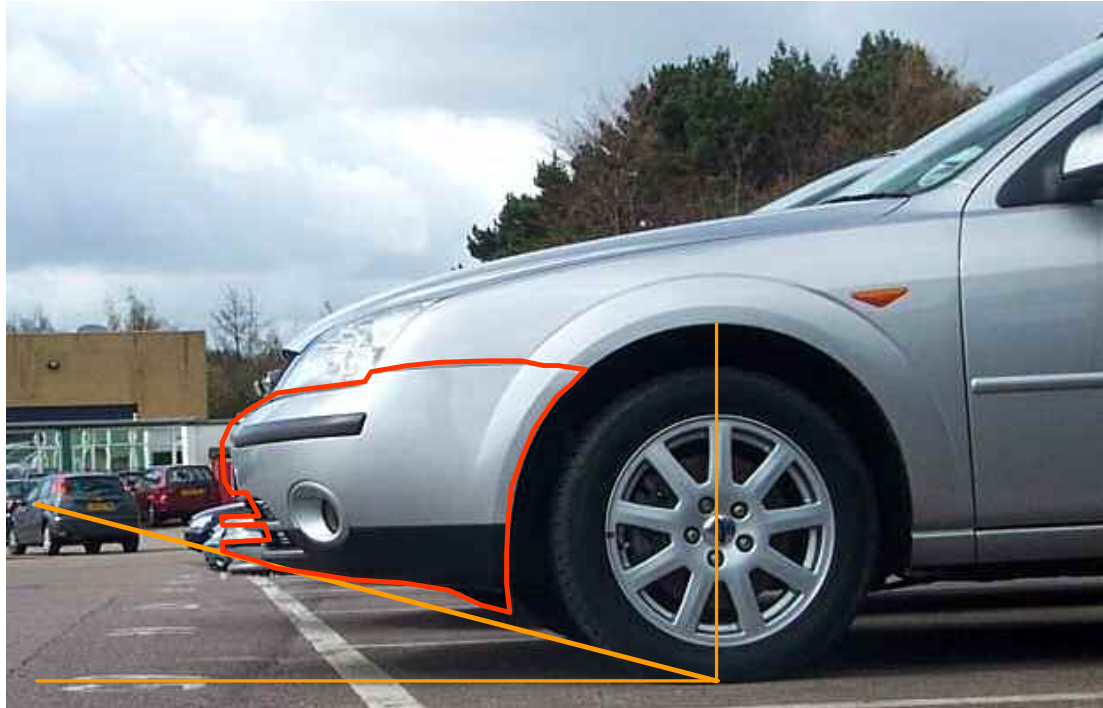

Figure 8.25. Diagram showing the bumper extension and spoiler re-profiling

The decision not to infringe on the ramp angle has a consequence for the cooling system of the car. By raising the lower edge of the bumper fascia, the potential area for the intake of air is reduced. To account for this, the air intake area of the bumper fascia that has been removed through the positional change needs to be reintroduced. Figure 8.26 shows the existing bumper air intake area of the Mondeo (shown in green) with the surrounding structural elements (shown in grey). Figure 8.27 shows the proposed changes to the bumper fascia area. The lower bumper edge has been raised, which reduces the air intake area of the lower cavity. In response the upper cavity in the bumper fascia has been widened and turned out at the upper edges rather than being curved in.

The modifications shown here are an initial thought and are open to subjective design alterations, where only the cosmetic appearance of the bumper fascia is altered. However, the modifications exemplify those that would be necessary to maintain the air intake area.

The front edge of the spoiler normally has little support. Now that the spoiler has been brought forward, the support to the lower edge needs to be increased in order to minimise the knee bending angle. However, this strengthening must not be taken too far or it could introduce local injuries in the ankle area. To provide this support, it is proposed to use a ribbed under-tray similar to that used in the Volvo S40 and shown in Figure 8.28, fitted between the lower edge of the bumper and the cross-member beneath the cooling pack.



Figure 8.26. Existing bumper fascia air intake design



Figure 8.27. Modification to the bumper fascia required to maintain both the ramp angle and air intake area



Figure 8.28. Ribbed under-tray and bumper fascia from the Volvo S40

Following the repositioning of the bumper beam, the introduction of an energy-absorbing material between the bumper beam and the bumper fascia, and the introduction of a low load path in the bumper, the stiffness of these elements would need to be tailored to give the optimum performance in the legform test. This optimisation process would be achieved initially using mathematical simulations of the components and then of the integrated system, followed by some practical validation testing.

8.2.3.2 Upper legform to bonnet leading edge

As was estimated through consideration of the Euro NCAP upper legform test results for the Ford Mondeo, the Mondeo had crushed by approximately 115 mm on the centreline. Theoretical estimation of the new test procedure and requirements, suggests that 110 mm of crush depth is required to pass the peak force criterion within the more demanding zone, therefore the Mondeo already has just sufficient crush space. However the existing crush depth is likely to be slightly too stiff as the original test recorded a high peak impactor force of 7.27 kN, which is about 1 kN over the required maximum force of 6.25 kN and 2.27 kN over the manufacturers' design target of 5 kN. It is thought that this change in crush force can be achieved by minor changes in the Bonnet Leading Edge (BLE) design that will have no additional manufacturing cost for the central area of the BLE. For these costings it has been assumed that a collapsible bonnet striker and deformable headlamps will be the only additional pedestrian features. The bonnet lock striker will be modified to make it deform

more readily and be of the form of that already used in the Ford Focus C-Max, as shown in Figure 8.29.

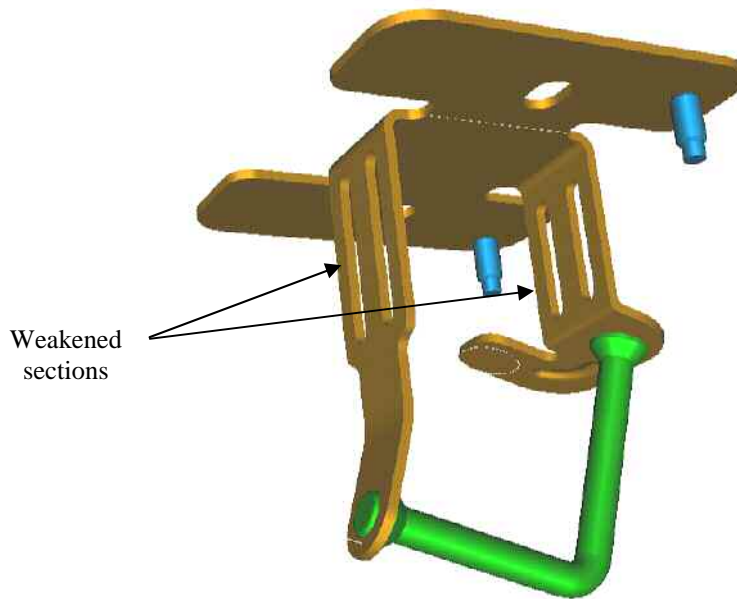

Figure 8.29. Weakened bonnet striker as used in the Ford Focus C-Max

As the BLE runs along the intersection between the bonnet and the headlamps, the headlamps will need to be made deformable. Deformable headlamps with deformable lenses and reflector boxes are currently being developed to provide pedestrian protection and are already fitted to the Honda Civic and the new Volvo S40. Therefore, similar units will be used with styling to match the current Mondeo lamps. As with most current vehicles the headlamps are required to match the styling requirements for the specific model although sharing of some components may be possible. The alternative solution of mounting the headlamp on frangible mountings will not be used because it is thought that headlamps may become too heavy to be moved bodily back into the vehicle during an upper legform test. This additional weight is likely to be caused by the use of more powerful light sources and introduction of intelligent interactive adjustment of the headlamp direction and pattern to aid the driver seeing dangers to the side and around bends.

For any parts of the BLE width where it is difficult to achieve the desired stiffness, for example where the bonnet is supported by the uprights each side of the cooling pack, the manufacturer can nominate these for the less demanding relaxation zone requirements of 7.5 kN and 510 Nm.

Following the introduction of the deformable bonnet lock striker and headlamps, the stiffness of the BLE and underlying elements would need to be tailored to give the optimum performance in the upper legform test. This optimisation process would be achieved initially using mathematical simulations of the components and then of the integrated system, followed by some practical validation testing.

8.2.3.3 Headform to bonnet top

For the headform tests, there are four different requirements for crush depth that come from testing with both the adult and child headform impactors over the two regions of HIC requirements. By two regions of requirements, it is meant that one region is the relaxation zone, where up to 25 percent of the test area can be nominated by the manufacturer to meet the less demanding requirement of $HIC < 2000$. The second region of at least 75 percent of the bonnet top test area must meet the more demanding requirement of $HIC < 1250$. The corresponding minimum crush depths necessary to meet

the requirements for these areas are, for the adult headform, 85 mm for the HIC 1250 area and 64 mm for the HIC 2000 area. For the child headform, total minimum crush depths of 69 mm and 52 mm respectively can be calculated. These minimum crush depths include an allowance of 5 mm for the residual depth occupied by the crushed material (this will be variable across the headform test areas but should be approximately correct for the worst areas such as the wing edges).

As with the other tests, the bonnet top crush depth alone will not satisfy the requirements of the proposed phase two of the Directive. The stiffness and deformation of the bonnet are also critical, therefore any assumption that the requirements can be met through the provision of adequate crush depth in the bonnet top also requires tailoring of the bonnet stiffness. To provide approximately the required stiffness of bonnet for the protection of pedestrians, the bonnet should have an underlying structure without localised stiff points. For the Mondeo this would mean revising the bonnet under-frame to have a more homogeneous stiffness. The Ford Focus C-Max has a more uniform inner bonnet skin to provide a more uniform stiffness for the assembled bonnet (see Figure 8.30). For these costings it will be assumed that this design will be adapted and refined to suit the Mondeo.

The stiffness of the bonnet and the supports along each edge would need to be tailored to give the optimum performance in the headform test. This optimisation process would be achieved initially using mathematical simulations of the components and then of the integrated system, followed by some practical validation testing.

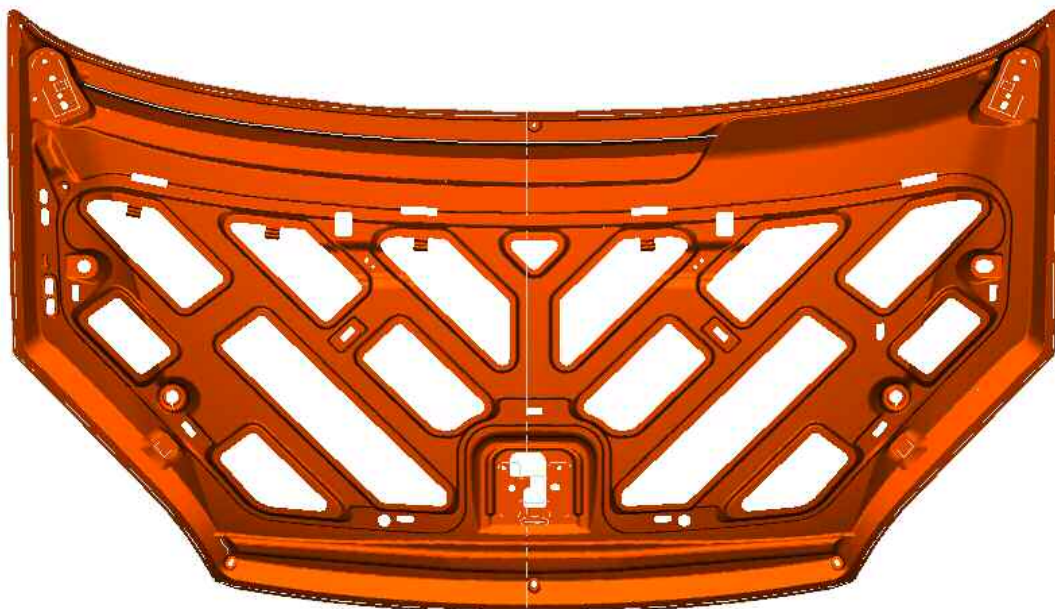

Figure 8.30. Ford Focus C-Max bonnet inner skin

To establish high points in the engine bay, measurements were made between the high features under the bonnet and the bonnet underside (sound-proof padding), and an allowance has been made for the thickness of the bonnet in the approximate crush depths that were estimated. These crush depth estimations, for one petrol and one diesel variant, are shown respectively in Figures 8.31 and 8.32. It can be seen, through comparison of the two figures, that the diesel engine variant is slightly larger than the petrol engine with the engine block being between 40 and 60 mm from the bonnet as opposed to 70 to 80 mm, respectively. The 70 to 80 mm clearance would be sufficient to meet the HIC 1250 requirements for much of the head impact test area. Some of the remaining area would meet the HIC 2000 requirement; however, some of the area with clearances down to 40 mm would not be sufficient. Therefore it is proposed to raise the bonnet 35 mm and revise the reinforcement plate on top of the McPherson strut tower (which most cars do not have), to obtain an extra 15 mm in this area.

With a very slightly higher bonnet, it is thought that the test could be passed for the engine block area, using some of the allowed relaxation area.

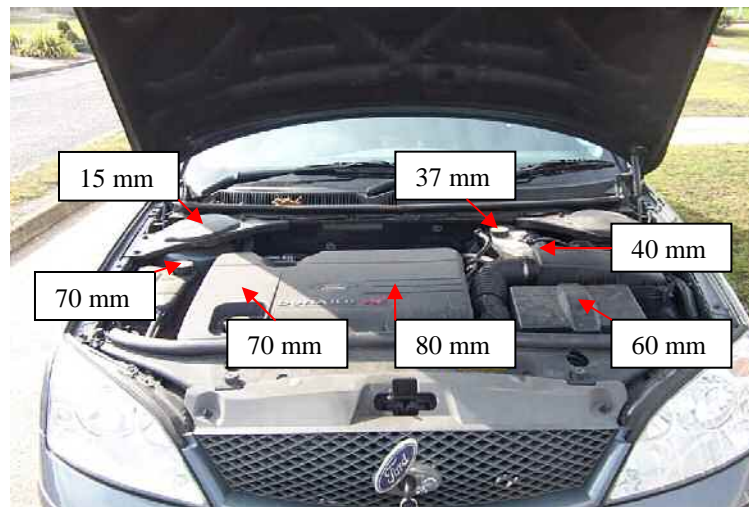

Figure 8.31. Approximate crush depth measurements (petrol variant)

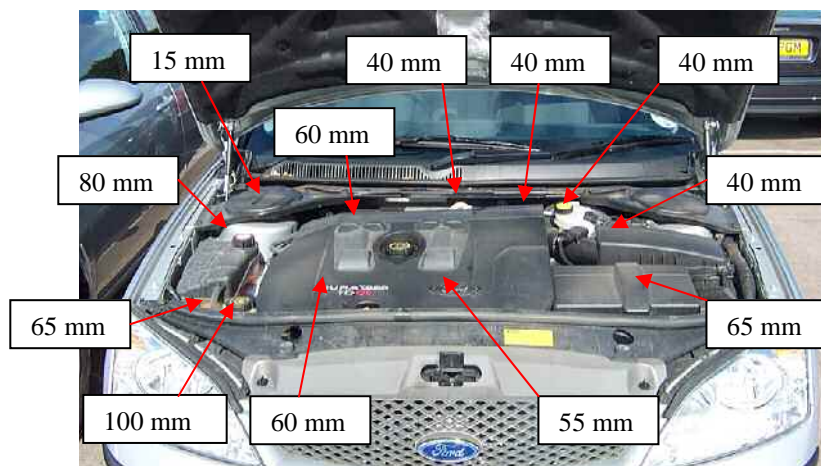

Figure 8.32. Approximate crush depth measurements (diesel variant)

It would have been useful to compare the engine to bonnet clearance in a larger engine variant, such as the 2.5 L petrol engine. To determine this, clearance measurements were made of the 2.5 L engine variant and compared with a smaller 1.8 L engine, for convenience the preceding model of Mondeo was used for this. It was found that the clearance of the high points were comparable between the two engine sizes but that the larger engine was close to the bonnet for a greater area of the bonnet, as a proportion. This has implications for the relaxation zone, as it may only cover 25 percent of the bonnet top area. The large engine block close to the bonnet would use too much of this area to make the rest of the bonnet top area feasible. To enable the entire bonnet top to be feasible with respect to passing the proposed phase two requirements, the region of the engine block should be made to meet the criterion of having HIC values less than 1250. Most of the engine block area, but not all, would meet this requirement with the additional 35 mm of crush depth provided by raising the bonnet, as mentioned above. It is assumed that some savings in engine height in critical areas could be made with a new vehicle, by modifications to the components concerned or the engine covers, but for the purposes of these costings, these changes have not been included.

To make the necessary 35 mm available, the bonnet would have to be lifted. Figure 8.33 shows a Mondeo with the bonnet lifted by 35 mm; the original bonnet is depicted by the green lines and the

new position shown by the red lines. Associated with the raising of the bonnet is the extension of the wings to maintain the fit between the bonnet and wing edges; this is shown in Figure 8.34.



Figure 8.33. Bonnet lifted by 35 mm to provide the necessary clearance underneath



Figure 8.34. Raised wing edge to match bonnet

Another issue to be considered with the raising of the bonnet is the view angle for the driver. If the bonnet is lifted too far, then the angles through which the driver can see will be reduced. If the view angle is made too small, then the seating position for the driver would need to be raised along with the

roof of the vehicle to allow for the same headroom. This will have associated weight, wind resistance and manufacturing costs and will not be a viable option for certain vehicles such as sports cars.

The legal minimum for a point directly in front of the driver is angle of 5° from the set point (equivalent to the position of the driver's eye) and uses an upper and lower height to cover some of the variation in stature seen in the population. Figure 8.35 shows a diagram on which downward view angles have been marked, shown by the orange lines. It was estimated that the existing Mondeo bonnet (green lines) allowed a downward view angle of approximately 8.6° . With the bonnet being lifted by 35 mm (red lines), this view angle has been decreased by almost 2° , making it approximately 6.6° . This is still within the legal limit and is therefore thought to be acceptable; however, it may not be ideal for the very short driver.



Figure 8.35. Revised view angles

After raising the bonnet by 35 mm, there are a few remaining high points which are dealt with below:

The current Mondeo McPherson strut reinforcing braces have a height of about 40 to 70 mm (as the towers are angled with respect to the braces). For a new vehicle, it should be possible to add reinforcement to the McPherson strut towers without the introduction of such high bracing beams. For these costings, it has been assumed that a more compact brace design can be produced with no extra cost.

Other high points in the engine bay are the air filter and the brake fluid reservoir. Both of these items could be made to be more deformable than they are currently. The air filter box will be made to be deformable by the use of fold initiators and, if necessary, revised plastic materials. For the brake fluid reservoir to be made frangible so that it will push down, it will be necessary to use slotted or deformable mountings. The current rigid combined mounting and fluid connections to the brake master cylinder will need to be replaced with flexible pipes along with a deformable or frangible mounting bracket. A similar arrangement to this was suggested for the Landrover Freelander and was used for the brake fluid reservoir on the Honda Civic, see Figure 8.22.

The wing edge of the Mondeo is supported on an in-turned section, raised above the wheel arch and upper longitudinal beam (see Figure 8.36). There is already sufficient crush depth available above the upper longitudinal beam to pass both the child and adult headform tests. However, to control the energy absorption, deformable elements would be needed under the raised wing edge. Examples of such elements are found in the Ford Focus C-max (see Figure 8.37). Figure 8.38 shows the position of these brackets when they are mounted on the wing edge of the Focus C-Max. However, removing the solid upstand and replacing it with these deformable brackets will leave a cavity which needs to be sealed to control under bonnet air flow / fumes, to prevent them reaching the occupant compartment. To provide this preventative measure, a deformable gas-management closing panel would also be needed between the upper longitudinal and the underside of the wing edges.

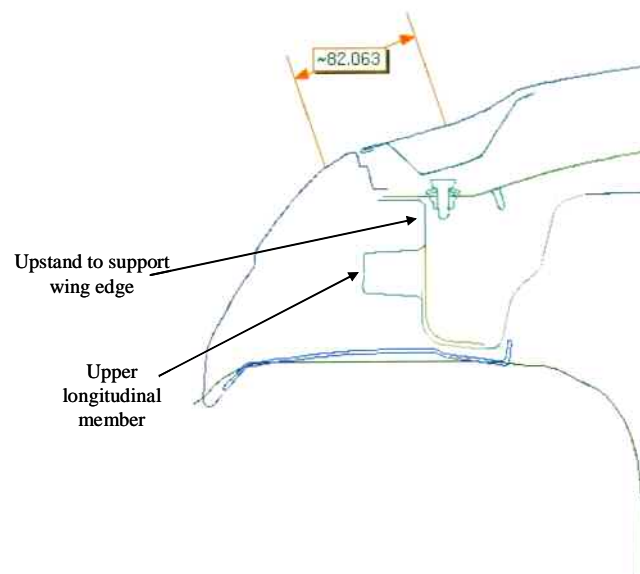

Figure 8.36. Cross section of the current Mondeo at the top of the wheel-arch



Figure 8.37. Deformable wing edge brackets used in the Ford Focus C-Max

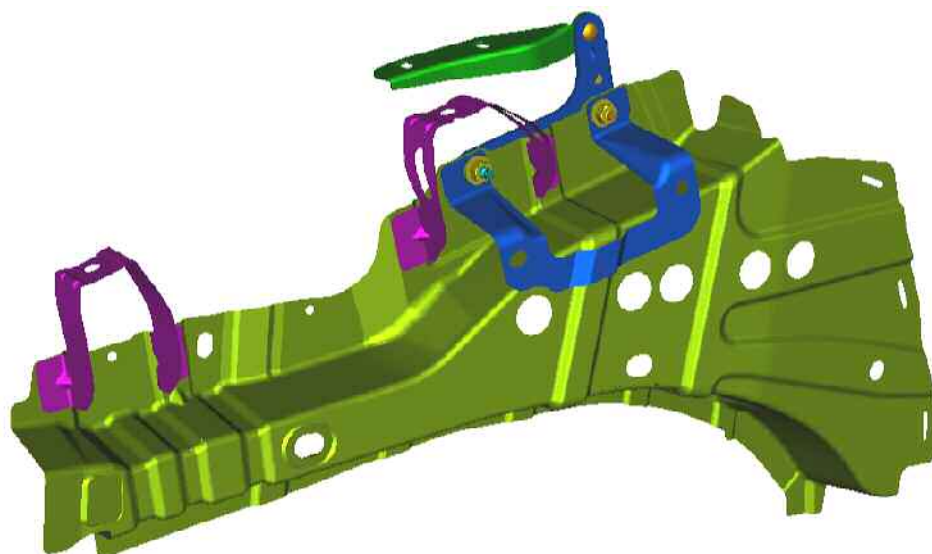
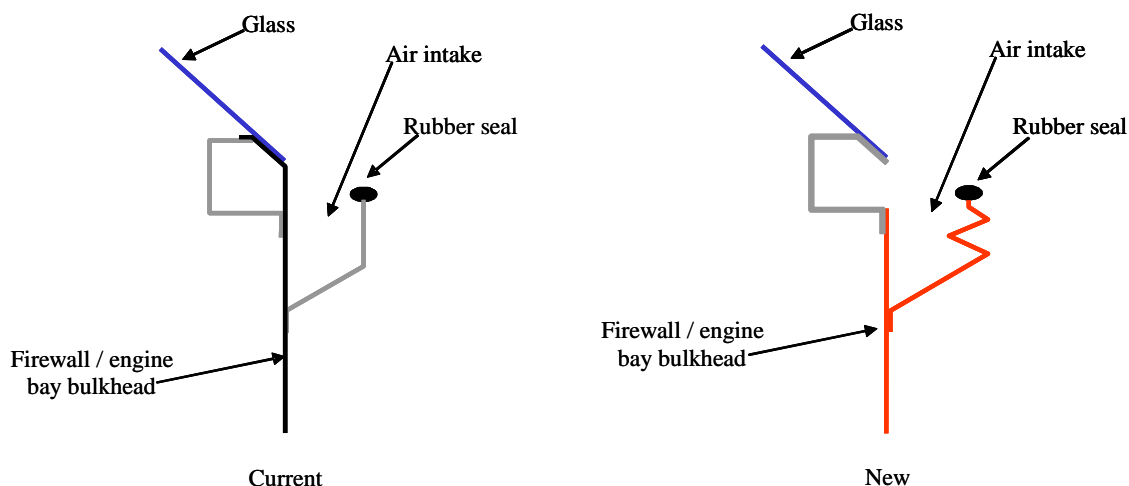

Figure 8.38. Position of deformable brackets when mounted in the Ford Focus C-Max

The base of the windscreen for a new Mondeo-sized vehicle will have a C-shape form similar to that used to provide pedestrian protection in the Honda Civic, as described in the Landrover Freelander modifications (see Figure 8.15). In the middle, where the overhang is greatest due to the curvature of the windscreen, some additional collapsible bracing within the C-section may be necessary.

The forward extension from the firewall, which forms the heater air intake chamber and wiper recess in the Mondeo, is too stiff. This comprises an angle section coming from the firewall, with a rubber seal on the top, which supports the rear edge of the bonnet. To reduce the stiffness of this element, fold initiators in the form of corrugations will be added to the angle section. Figure 8.39 shows a schematic representation of the current and modified structure.



At the centreline of the vehicle

Figure 8.39. Schematic representation of the current and modified sections for the extension of the firewall to form the scuttle heater / ventilation air chamber

The wiper spindles do not need modification as they are tucked under the bonnet and already pass the HIC 1250 criterion (with a HIC of 1069, as tested in Euro NCAP) and this should be improved by the additional 35 mm of crush depth from raising the bonnet.

The bonnet hinges in the Ford Mondeo, even though they are recessed into the engine bay, do not meet the requirements for phase two of the EC Directive (with a HIC of 2182, as tested in Euro NCAP). To meet the HIC requirement, the hinge will need to be made to be frangible. An example of a frangible hinge is available on the Ford Focus C-max (Figures 8.40 and 8.41). This design works through having a shear pin mounting at the rear of the hinge, where it is bolted to the vehicle. The shear pin is riveted onto the hinge and is waisted to initiate the shearing action. When impacted, this pin shears allowing the hinge to rotate into the engine bay. As well as being frangible, there also needs to be the available stroke depth for the sheared hinge to rotate into. With the tested HIC value being so close to the required 2000, it is believed that the necessary stroke depth will be available with the increase in the height of the wing edge.

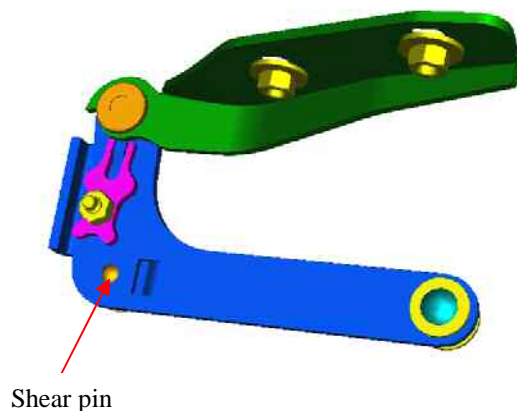

Figure 8.40. Shear pin hinge from the Ford Focus C-Max (engine bay side)

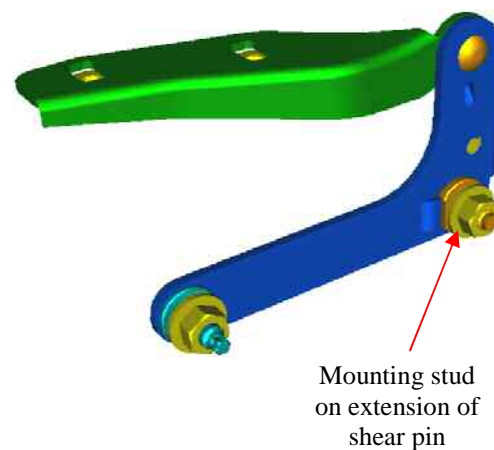

Figure 8.41. Shear pin hinge from the Ford Focus C-Max (wing side)

For a vehicle of this size, the child to adult transition is likely to be towards the rear of the engine. It may be possible to provide the necessary 90 mm of crush depth in much of the transition area by raising the bonnet by 35 mm and by optimisation of the size and relative position of components. Any small problem areas remaining could be nominated for the HPC 2000 test. For the purpose of this exercise it has been assumed that this will be sufficient. However, the alternative of using pop-up bonnets for this sector has also been included in the costs for the fleet calculations in Section 9.

Another option is to raise the bonnet by a further 15 mm, however, this will further reduce the view angles. In this case it may be necessary to raise the seating position and roof-line by 15 mm to maintain an acceptable view angle. As discussed above, this could have implications for weight, wind resistance and manufacturing costs and it has been suggested by manufacturers that increased fuel consumption because of such changes might be significant. It is therefore interesting to look at the fuel consumption figures of two almost identical base vehicles, one with a high roof and one with a lower roof. It is thought that the Ford Focus and the Ford Focus C-Max are very similar with the exception that the C-Max is about 150 mm higher. Despite this it is interesting to note that although it is not possible to compare the consumption of identical engines, the fuel consumption of these two similar capacity vehicles are almost identical.

8.2.4 Ford Mondeo – pedestrian impact cost implications

Again, Menard Engineering Limited first considered the feasibility of the TRL proposals, for the Ford Mondeo as described in Section 8.2.3 above, and revised them where necessary using their specialised

vehicle engineering experience. They then produced an estimate of the extra costs for pedestrian protection that would be incurred in producing a totally new vehicle of the same class and similar architecture. Although based on the changes to the Mondeo, they calculated costs for a more generic vehicle of the same category.

The report on the Mondeo, produced by Menard Engineering Limited, is presented below and has been unchanged by TRL Limited.



Mondeo – Pedestrian Impact Cost Implications

26 April 2004

Contents

General Assumptions	3
---------------------	---

This section of the report covers the following areas of the vehicle Trim:-

1. Front Bumper Facia (including Lower Spoiler Area)	3
2. Front Bumper Energy Absorbing Foam	4
3. Front Undertray	4
4. Headlamps	5

This section of the report covers the following areas of the BIW:-

5. Head Lamp bracket moved foreword.	6
6. Energy Absorbing Crash Cans.	6
7. Pressed Main Bumper Beam.	7
8. Pressed Crush Beam with initiators to Front Bumper.	7
9. Bracket Bonnet Latch.	7
10. Bonnet Inner Panel extended.	8
11. Bonnet Outer Panel extended.	8
12. Modify Front Fender Outers at front & top edge.	9
13. Brake & Fluid Reservoirs & pipes, reposition bracket with crushable mounts.	9
14. Air Filter and Fuse Box with crushable mounts – Remove engine cover.	9
15. Engine position – Engine mounts – Modifications required. [See Appendix A]	10
16. Front Fender Mounting brackets.	10
17 Shot Gun LH & RH Upper Wheel Arch Longmember Beam.	10
18. Modify Firewall / Engine bay Bulkhead – add crush zone.	11
19. Bonnet Hinge fixed with breakaway bolts or bracket with crushable mounts.	12

Summary of Costs	13
------------------	----

Appendix A - Consideration on Pedestrian Protection Legislation effects on Vehicle Design	14
---	----

General Assumptions

This report is based upon the TRL Report on the Ford Mondeo and the modifications required to meet a revised version of Phase 2 of the EC Directive on Pedestrian Protection. It assumes an estimated vehicle volume of 180,000 per annum.

The On-Cost figures show the estimated cost effect of the Pedestrian Protection legislation on a New Vehicle Design (not for modifying an existing vehicle).

The costs exclude design and development.

1. Front Bumper Facia

Workscope

Front Bumper Facia depth increased by 15mm forward, the Spoiler area moved forward and upward and the Lower Grille configuration modified.

Notes

For this exercise it is assumed that the Front Bumper Facia will be a design based on the existing Mondeo, using similar fixings, Fog Lamp, Grilles, etc. It will be a one piece painted Injection Moulded part. The costs below are given for a full new Bumper Facia and the Pedestrian Impact On-Cost is for the additional tool size and part material due to the depth increase. It is assumed that the Upper Grille is not changed for this exercise.

The Spoiler Area, which is part of the main moulding, will be designed to meet Aerodynamic and Cooling requirements with no detriments using analysis. It will also have to meet all Ground Clearance and Kerb Height requirements.

The Spoiler Area will incorporate the Lower Grille Areas and they can be configured as shown on the TRL report subject to package and meeting the cooling requirements. If the new Lower Grille proposed shape does not cover the areas required for Cooling then some additional Ducting may be required. An allowance for this is also included in the costing. There will be an additional tooling cost for the grilles as they are longer.

The Grilles, Fog Lamps, Parking Distance Sensors and Headlamp Wash Systems

Which can all be fixed to the Front Bumper System should also be considered with respect to Pedestrian Protection. The Mounting Designs for these items should be such that in an Impact they allow the movement of the items rearward or allow them to breakaway without leaving any sharp objects. The On-Cost for doing this to make them Pedestrian Impact friendly could be considered as minimal.

Facia Piece Part Costs

Front Bumper Assembly (excluding Fog Lamps) = £65

Pedestrian Impact On-Cost = £3

Facia Tooling Costs

Front Bumper Facia and Grilles = £900,000

Pedestrian Impact On-Cost = £40,000

2. Front Bumper Energy Absorbing Foam (Alternative to item 8)

Workscope
Front Bumper Energy Absorber.

Notes

Although the existing Mondeo has Energy Absorbing material (for Low Speed Impact requirements) between the Beam and the Facia, for this exercise it is assumed that this Energy Absorbing material will have to be increased in area. There are various materials available such as Steel Pressed Beams (also costed in this study), Aluminium Honeycombs and EPP Moulded Foams. For this exercise we have chosen EPP Moulded Foam. The Density of the Foam will be in the region of 60g/l and this will be confirmed by Analysis to meet the requirements of both Low Speed and Pedestrian Impact requirements.

Note that although this could be considered as an On-cost for Pedestrian Impact the Energy Absorber could already be a requirement due to Low Speed Impact requirements and any tailoring to meet Pedestrian Impact will have minimal cost effect.

Foam Piece Part Costs
Front Bumper Foam = £5

Pedestrian Impact on Cost = £2

Foam Tooling Costs
Front Bumper Foam = £18000

Pedestrian Impact on Cost = £2000

3. Front Undertray

Workscope
Ribbed Front Undertray supporting the Front Lower Spoiler.

Notes

Front Undertray will be an Injection Moulded (PP) part. The Fixings are to use existing any available fixing positions for the Engine Splash Guard. Some additional Fixings may be required to give adequate support.

The Undertray will be fixed to the Front Lower Spoiler with J-Clips and Screws. The Structural Rib pattern to Support the Spoiler will be designed with the aid of Analysis techniques.

The Undertray will also be designed to not be detrimental to the Cooling and Aerodynamic requirements with the aid of Analysis and Testing.

It should be noted that we are assuming that this Undertray is covering the Front Section of the Engine Bay only and is not considered as a Full Engine Bay Undertray. It should also be of no detriment to Kerb Height requirements.

It should also be noted that many new vehicles have Undertrays to meet NVH, Aerodynamic and Cooling requirements but for this exercise we are assuming that it is a new item fitted to support the Lower Spoiler area of the Bumper.

However an Undertray is already fitted on the new Mondeo and is in the correct area to support the Spoiler. Designing it to support the Spoiler further should be achievable for a negligible on cost (Some additional fixings and ribs) which is shown below.

Piece Part Costs

Undertray Moulding & Fixings = £5

Pedestrian Impact on Cost = £1.50

Tooling Costs

Undertray Moulding = £150,000

Pedestrian Impact on Cost = £10,000

4. Headlamps

Workscope

Headlamps designed as Pedestrian Impact friendly.

Notes

The Headlamps can be designed with breakaway mountings (part of the main moulding) and with deformable Polycarbonate lenses and reflector boxes.

Current design trend is to use polycarbonate lenses therefore there would be no requirement to change lens material for pedestrian impact legislation. The current Mondeo has PC lenses.

The deformable lamp structure would be accommodated by the design of flexible or breakaway mounting lugs/brackets. If this was identified as a requirement at the beginning of a project there would be negligible on-cost to the lamp.

However if a breakaway mounting system is adopted a repair kit would need to be designed and tooled. So the piece price and the tooling costs would be treated as After Market sales costs.

Piece Part Costs

Headlamp System = £35 (single pocket type) to £100 (Xenon type)

Pedestrian Impact On-Cost = £0

Tooling Costs

Headlamp System = £2.5 Million

Pedestrian Impact On-Cost = £0

Repair Kit Piece Part Costs

Repair Kit = £00

Pedestrian Impact On-Cost = £00

Repair Kit Tooling Costs

Repair Kit Tooling = £00,000

Pedestrian Impact On-Cost = £00,000

This section of the report covers the areas of the vehicle for Body in White.

Relative to the Freelander report the tooling costs have been increased by 5 – 10% and the piece price costs reduced between 10 – 13%, as the Mondeo vehicle volume per year has been based on 180,000 / year.

The On-Cost figures show the estimated cost effect of the Pedestrian Protection legislation on a New Vehicle Design (not for modifying an existing vehicle).

5. Head Lamp bracket moved forward.

Workscope

Head Lamp bracket moved forward by 35mm.

Notes

The head lamp one piece pressed steel panel would require all the fixing positions to have crushable mounts, the mount may need depressions with cut away portions into the steel work or dog legged fixing flanges, on impact the mounts would collapse giving a crushable zone area. The number of tooling operations would increase from three to four ops, and so there are separate LH & RH tools sets.

This type of panel manufacture with deformable mounts would be required to support and hold a glass lens with a plastic headlamp casing, but as we are suggesting the use of a deformable Polycarbonate lens and reflector boxes, this steel head lamp panel costs are not required.

Piece Part	Costs LH & RH are + £ 0.00p
Press Tooling	Costs LH & RH are + £ 00,000
Assembly Tooling	Costs £ nil

The above costs do not take into consideration – Panel manufacturing feasibility, tool & assembly process modifications, Panel & Tool development programmes.

6. Energy Absorbing Crash Cans.

Workscope

Folded steel Crash Cans are required between the front long members and the introduction of a pressed steel Front Bumper Beam. This new set up to replace the Hydroformed Front Bumper Beam.

Notes

The steel folded front crash cans consist of two parts, a three sided inner and a closing outer panel, the parts have out turned flanges at the rear which are spot welded to the longmembers and out turned flanges at the front and bolted to the Front Bumper Beam for easy repair. The parts are to be designed symmetrical from LH to RH sides of the vehicle, the three sided part to be produced in three operations and the closer in a combined crash form and flange tool. The fixture to hold, locate and support both the LH and RH assemblies in one jig prior to the spot welding taking place.

Piece Part	Costs LH & RH are + £ 2.05p
Press Tooling	Costs LH & RH are + £ 84,000
Assembly piece part	Costs one assy are + £ 0.80p
Assembly Tooling	Costs one fixture are + £ 11,200

The above costs do not take into consideration – Panel manufacturing feasibility, tool & assembly process modifications, Panel & Tool development programmes.

7. Pressed Main Bumper Beam.

Workscope

To produce a two piece pressed steel Front Bumper Beam which will carry a steel pressed front crush beam and the plastic front Bumper.

Notes

The front Bumper Beam will consist of a pressed steel front section with spot weld flanges and a closing panel, the fixing bolts will be offered from the front of the Bumper Beam through to the LH & RH crash can weld nuts. The pressed front section to be produced in three operations and the closer in a combined crush form and flange tool. The fixture to hold, locate and support the pressed steel Main Bumper Beam and the steel front crushable Beam, this assembly to be spot welded first and then the fixture to support and locate the closing panel which is then spot welded, baffles and reinforcements are also included into this assembly prior to this operation. As this part replaces the current hydroformed part it is not an on-cost classed as pedestrian protection.

Piece Part	Costs LH & RH	are + £ 0.00
Press Tooling	Costs LH & RH	are + £ 0.00
Assembly piece part	Costs one assy	are + £ 0.00
Assembly Tooling	Costs one fixture	are + £ 0.00

The above costs do not take into consideration – Panel manufacturing feasibility, tool & assembly process modifications, Panel & Tool development programmes.

8. Pressed Crush Beam with initiators to Front Bumper(Alternative to item 2)

Workscope

Bumper Beam to have pressed depressions.

Notes

Bumper Beam to have pressed depressions into the top and bottom panel surfaces to act as crush initiators; this will require three press tooling operations. This will be a new pressed steel panel and become an assembly with the current front beam; a new fixture is required to locate and spot weld the two together.

Pressed Piece Part	Costs one compt	are + £ 2.80p
Press Tooling	Costs one compt	are + £ 160,000
Assembly piece part	Costs one assy	are + £ 1.12p
Assembly Tooling	Costs one fixture	are + £ 7,500

The above costs do not take into consideration – Panel manufacturing feasibility, tool & assembly process modifications, Panel & Tool development programmes.

9. Bracket Bonnet Latch.

Workscope

The bracket Bonnet Latch mounting to have crushable fixing mounts to the Bonnet inner Panel.

Notes

The Latch and striker bracket to the Bonnet inner Panel require crushable mounts, this will increase the number of press tool operations from three ops to four ops

Pressed Piece Part	Costs one compt	are + £ 0.25p
Press Tooling	Costs one compt	are + £ 33,000
Assembly piece part	Costs	£ nil
Assembly Tooling	Costs	£ nil

The above costs do not take into consideration – Panel manufacturing feasibility, tool & assembly process modifications, Panel & Tool development programmes.

10. Bonnet Inner Panel extended.

Workscope

Bonnet inner panel extended by 35mm to match Bonnet outer and the front bumper position.

Notes

The front Bonnet inner panel area will extend forward and therefore a percentage of 5% extra costs for the sheet steel and size of the pressed tooling set has been considered for this current exercise. The number of press tool - operations considered were three, now four ops running in a 500 to 800 ton press, auto sheet load and unload and manual load auto unload of the part there after.

Pressed Piece Part	Costs one compt are + £ 0.35p
Press Tooling	Costs one compt are + £ 18,000
Assembly piece part	Costs are as below in section 12
Assembly Tooling	Costs are as below in section 12

The above costs do not take into consideration – Panel manufacturing feasibility, tool & assembly process modifications, Panel & Tool development programmes.

11. Bonnet Outer Panel extended.

Workscope

Bonnet outer panel extended by 35mm to match the front bumper position.

Notes

The front Bonnet outer panel area will extend foreword and therefore a percentage of 5% extra costs for the sheet steel and size of the pressed tooling set has been considered for this current exercise. The number of press tool - operations considered is four ops running in a 500 / 800 ton press, auto sheet load and unload and auto load auto unload of the part there after.

The Hemming operation of the outer flange to the inner panel [the clinch flange] for this exercise to be performed on a free standing Hemming fixture, the fixture will increase in size, therefore a percentage of 2% extra costs for the final assembly has been considered for the current exercise.

Pressed Piece Part	Costs one compt are + £ 0.40p
Press Tooling	Costs one compt are + £ 20,000
Assembly piece part	Costs one assy are + £ 0.30p
Assembly Tooling	Costs one fixture are + £ 4,900

The above costs do not take into consideration – Panel manufacturing feasibility, tool & assembly process modifications, Panel & Tool development programmes.

12. Modify Front Fender Outers at front & top edge.

Workscope

The front Fender LH & RH to move forward to meet the new position of the headlamp and to increase in height to suit Bonnet level.

Notes

The increase in the front Fender costs for LH & RH components has been based on an increase of costs by 5% for each hand. For this exercise it is assumed that each front Fender Outer is produced on its own set of tools for each hand, six press operations per hand, running in a 1000 ton press, the piece and tooling prices have then been calculated.

Pressed Piece Part	Costs two compt are + £ 0.49p
Press Tooling	Costs two compt are + £ 58,000
Assembly piece part	Costs £ nil
Assembly Tooling	Costs £ nil

The above costs do not take into consideration – Panel manufacturing feasibility, tool & assembly process modifications, Panel & Tool development programmes.

13. Brake & Fluid Reservoirs & pipes, reposition bracket with crushable mounts.

Workscope

Brake & Fluid Reservoir container to be lowered repositioned and redesigned with crushable mounts.

Notes

This steel pressed component tooling operations would increase from two to three ops to produce the crushable mount zones, the press tools would run in a 100 ton press. The assembly cost of the bracket to the body in white will not be modified.

Pressed Piece Part	Costs one compt are + £ 0.22p
Press Tooling	Costs one compt are + £ 23,000
Assembly piece part	Costs £ nil
Assembly Tooling	Costs £ nil

The above costs do not take into consideration – Panel manufacturing feasibility, tool & assembly process modifications. Panel & Tool development programmes,

14. Air Filter and Fuse Box with crushable mounts or structures.

Workscope

There are 2 possible options:

1. Air Filter and Fuse Box containers to be lowered repositioned and redesigned with crushable mounts.
2. Air filter and Fuse Box to have crushable structures

Notes

For crushable mounts the steel pressed component tooling operations would increase from two to three ops to produce the crushable mount zones, the press tools would run in a 100 ton press. The assembly costs for these brackets to the body in white would not be modified.

The crushable brackets would not be required if the Air Filter and Fuse Box plastic components were manufactured using a softer material and incorporated collapsible mounts in the plastic component, on impact this type of construction would deform out of the way. This is the preferred solution therefore the piece price and tooling costs can be removed from the report.

Air Filter steel bracket

Pressed Piece Part	Costs one compt are + £ 0.00p
Press Tooling	Costs one compt are + £ 00,000
Assembly piece part	Costs £ nil
Assembly Tooling	Costs £ nil

Fuse box steel bracket

Pressed Piece Part	Costs one compt are + £ 0.00p
Press Tooling	Costs one compt are + £ 00,000
Assembly piece part	Costs £ nil
Assembly Tooling	Costs £ nil

The above costs do not take into consideration – Panel manufacturing feasibility, tool & assembly process modifications, Panel & Tool development programmes.

15. Engine position – Engine mounts – Modifications required. [See Appendix A]

Workscope

The Engine bay package would require a great deal of re – engineering, this will effect Panel and assembly tooling Manufacturing production line processes and development costing.

Notes

The potential impact on panel and tooling costs have not been included – refer to Appendix A

16. Front Fender mounting brackets.

Workscope

New deformable Front Fender fixing brackets required between the Shot Gun pressed panel and the LH & RH Front Fenders.

Notes

These new steel formed and flanged brackets to have cut away areas in the side mounts which are fixed to the shot guns, these new mounts are crushable on impact. The front and the rear brackets are produced in a set of tools with LH & RH parts being manufactured together in a 200 ton press with four operations.

No fixtures are required.

Pressed Piece Part	Costs	compt are + £ 3.52p
Press Tooling	Costs	compt are + £ 169,000
Assembly piece part	Costs	assy are + £ 0.00p
Assembly Tooling	Costs	fixture are + £ 00,000

The above costs do not take into consideration – Panel manufacturing feasibility, tool & assembly process modifications, Panel & Tool development programmes.

17. Shot Gun LH & RH Upper Wheel Arch Longmember Beam.

Workscope

The Shot Gun component is to be redesigned with an up standing flange, this flange is for securing the crushable mounting brackets which will support the front fenders.

Notes

The component would have been produced in three operations, but for this report it will be increased to four operations in single LH & RH tools running in a 400 ton press. The cavity that is left will require a suitable material to fill the gap and seal off any engine bay fumes, this could be produced

from either steel or plastic depending what strength is required from an FEA tensional stiffness calculation.

The shot gun component LH & RH will require an assembly fixture to hold and locate the front fender fixing brackets two off per side for spot welding to take place, the costs given include LH & RH assemblies.

Pressed Piece Part	Costs	compt are + £ 0.70p
Press Tooling	Costs	compt are + £ 98,000
Assembly piece part	Costs	assy are + £ 1.74p
Assembly Tooling	Costs	fixture are + £ 9,000

The above costs do not take into consideration – Panel manufacturing feasibility, tool & assembly process modifications, Panel & Tool development programmes.

18. Modify Firewall / Engine bay Bulkhead – add crush zone.

Workscope

The Engine bay Bulkhead to be modified by adding a crush zone into the front vertical face, the rear bonnet seal is fixed to this top surface.

Notes

This steel pressed component tooling operations would increase from three to four ops to produce the crushable zone in the vertical face, the press tools to run in a 300 ton press line. Any components welded to this surface may need to be repositioned; the changes to the surface should not affect the assembly of this part to the firewall assembly complete.

Pressed Piece Part	Costs one compt are + £ 0.24p
Press Tooling	Costs one compt are + £ 37,000
Assembly piece part	Costs £ nil
Assembly Tooling	Costs £ nil

The above costs do not take into consideration – Panel manufacturing feasibility, tool & assembly process modifications, Panel & Tool development programmes.

19. Bonnet Hinge fixed with breakaway bolts or bracket with crushable mounts.

Workscope

The Bonnet hinges to have built in crushable zones either breakaway bolts or deformable mounts to the Bonnet assembly.

Notes

For this exercise it has been assumed the deformable mount route, with the upper half of the hinge steel leaf to be formed with crushable flange fixing points bolted to the Bonnet assembly.

This steel pressed component tooling operations would increase from two to three ops to produce the crushable zone in the vertical face; the press tools would produce LH & RH parts together and run in a 300 to 500 ton press. The assembly of the two half leaves with the changed form should not alter the production process at the supplies for the completed hinge.

Pressed Piece Part	Costs two compt are + £ 1.13p
Press Tooling	Costs two compt are + £ 25,500
Assembly piece part	Costs £ nil
Assembly Tooling	Costs £ nil

The above costs do not take into consideration – Panel manufacturing feasibility, tool & assembly process modifications, Panel & Tool development programmes.

Summary of Costs

Ref no	Report Section	PART DESCRIPTION	New Items	Compt	Additional	Additional
				& Assy Tool type	Manufacture piece cost / Vehicle	Tooling / Assy costs per Programme
1	FIGURE 1.7 FIGURE 1.8	FRONT BUMPER FACIA INCREASE DEPTH BY 28mm.		plastic	£3.00	£40,000
2	FIGURE 1.2	FRONT BUMPER ENERGY ABSORBING FOAM MATERIAL FOR LOW SPEED IMPACT		foam	£2.00	£2,000
3	FIGURE 1.9	FRONT UNDERTRAY UNDER TRAY TO SUPPORT FRONT LOWER SPOILER		plastic	£1.50	£10,000
4	1.1.2	HEADLAMPS - DESIGNED AS PEDESTRIAN IMPACT FRIENDLY REPAIR KIT WILL BE REQUIRED - NO COSTS FOR THIS REPORT	#	plastic plastic	£0.00	£0
5	1.1.2	FRONT HEAD LAMP - MOVED FOREWORD - NO COSTS FOR THIS REPORT - AFTER SALES. HEAD LAMP BRKT MODIFIED WITH CRUSHABLE FIXINGS-REQUIRED IF CLASS LENS ISUSED		pressed assy	£0.00	£0
6	FIGURE 1.1	ENERGY ABSORBING CRUSH CANS PRESSED SHEET METAL INNER AND OUTER LH & RH CRUSH CANS	#	pressed assy	£2.05 £0.80	£84,000 £11,200
7	FIGURE 1.3	PRESSED MAIN BUMPER BEAM TWO PIECE SHEET METAL PRESSED BEAM REQUIRED	#	pressed assy	£0.00 £0.00	£0 £0
8	FIGURE 1.4	PRESSED CRUSH BEAM TO FRONT BUMPER - ADD CRUSH INITIATION DEPRESSIONS. ADD FORM TOOL TO PRESS IN THE DEPRESSIONS.	#	pressed assy	£2.80 £1.12	£160,000 £7,500
9	FIGURE 1.10	BRACKET BONNET LATCH CUT OUTS TO BE ADDED TO PRODUCE A CRUSHABLE ZONE AREA		pressed assy	£0.25	£33,000
10	FIGURE 1.11	BONNET INNER PANEL - [SHEET METAL PRESSING] RAISE BONNET BY 35mm		pressed assy	£0.35	£18,000
11	FIGURE 1.12 FIGURE 1.13	BONNET OUTER PANEL - [SHEET METAL PRESSING] RAISE BONNET BY 35mm		pressed assy	£0.40 £0.30	£20,000 £4,900
12	FIGURE 1.15	MODIFY FRONT FENDER OUTERS LH & RH. REPOSITION FRONT EDGE TO HEAD LAMP - INCREASE HEIGHT OF TOP SURFACE.		pressed assy	£0.49	£58,000
13	FIGURE 1.17	BRAKE & FLUID RESERVOIRS & PIPES - CRUSHABLE BRAKE RESVR BRKT. FLUID RESERVOIRS & PIPES - CRUSHABLE FLUID RESVR BRKT.		pressed assy	£0.22	£23,000
14	FIGURE 1.17	AIR FILTER , CRUSHABLE PLASTIC HOUSING - ENGINE TOP COVER TO BE REMOVED. FUSE BOX - CRUSHABLE PLASTIC HOUSING - NO COSTS FOR THIS REPORT.		plastic plastic	£0.00 £0.00	£0 £0
15	FIGURE 1.17 FIGURE 1.14	ENGINE POSITION - ENGINE MOUNT - MODIFICATIONS. [SEE DOCUMENT] OR RAISE BONNET 35 - THIS COST IS IN ITEM				
16	FIGURE 1.19 FIGURE 1.20	FRONT FENDER MOUNTING BRACKETS - LH & RH 2 OFF PER SIDE. DEFORMABLE WING EDGE BRACKETS REQUIRED	#	pressed assy	£3.52	£169,000
17	FIGURE 1.20 FIGURE 1.18	SHOT GUN LH & RH UPPER WHEEL ARCH LONG MEMBER BEAM MODIFY PART WITH AN UP STAND FLANGE TO MOUNT FENDER BRACKETS		pressed assy	£0.70 £1.74	£98,000 £9,000
18	1.1.3.3 FIGURE 1.21	BASE OF THE WINDSCREEN [FIREWALL SECTION] THE MODDEO ALREADY HAS A C-SHAPED PANEL THE SAME AS THE HONDA CIVIC.		pressed assy		
19	FIGURE 1.22	MODIFY FIREWALL / ENGINE BAY BULKHEAD, ADD SWAGE FORM TOOL SWAGES TO BE ADDED TO FORM CRUSH ZONE.		pressed assy	£0.24	£37,000
20	FIGURE 1.23 FIGURE 1.24	BONNET HINGE - TO BE FIXED WITH BREAK AWAY BOLTS - SHEAR BOLTS SPECIALS. NEW BRKT MOUNT HINGE FIXING TO BONNET WITH CRUSHABLE INITIATORS.		pressed assy	£1.13	£25,500
				TOTAL COSTS	£22.61	£810,100
				With Foam Bumper Excludes 8	£18.69	£642,600
				With Pressed Beam Excludes 2	£20.61	£808,100

The above tooling costs can be spread over the model life (5 Years), hence divide the above by the number of years.

Notes for Consideration on Pedestrian Protection Legislation effects on Vehicle Design

To compliment the Piece and Tooling Costs details the following notes on the effects of Pedestrian Protection Legislation on Vehicle Design should also be considered. It should also be noted that the Piece and Tooling Costs do not include any Costings for any additional Design, Analysis and Testing.

Weight – Weight increases will occur due to additional components, deeper bumper, Lower Spoiler, higher Bonnet and longer vehicles. Any weight increase will have a negative effect on Emissions and Fuel Consumption Performance, as noted below.

Styling – Affects the Front End style on hood, bumpers, etc. Any concern that it will give a “chunkier” feel to vehicles and all will look similar is not really the case as Honda has successfully achieved the requirements with well styled vehicles that meet the current requirements. Vehicles will also be longer and have higher front ends but a capable design team should be able to accommodate this within any new style.

Package – It could be difficult to package Engines to give additional clearances (see attached notes). But designing systems as Pedestrian Impact friendly should be achievable especially working with the Supplier base. Forward vision Angle, Front Approach Angle, Kerb Strike Requirements, Airflow and Cooling performance can all be affected to their detriment.

Aerodynamics – The requirements to have a flatter Front end form will effect the Aerodynamic performance and potentially effect emissions, fuel consumption performance and vehicle NVH. The effects would be studied using CAE analysis and any issues resolved during the design process.

Emissions and Fuel Consumption – The combination of the weight increases and the Aerodynamic effects will have a negative impact on the vehicle's Emissions and Fuel Consumption Performance, which may require modifications to the Engine and Powertrain Systems. Furthermore, these changes are likely to have an effect on Vehicle Performance, Ride and Handling, High Speed Stability, Steering and Braking. Another issue to consider is the issue of effectively a softer Front end on the Airbag Sensor Calibration. The Calibration will need to take this into consideration.

Durability, Reparability and Serviceability (Insurance Ratings) – The requirement for breakaway or deformable Parts and Systems effectively weakens them. This will have a knock-on effect to the Vehicle Durability, its reparability (Thatcham) and its serviceability. Accurate Analysis for these items will be necessary to develop a compromise solution between all vehicle requirements.

Vehicle Target Setting – As stated the requirements for Pedestrian Protection legislation can affect various areas of the Vehicle Attributes. When the vehicle targets are set at the beginning of the program consideration should be given to this.

Material Selection – When materials are selected Pedestrian Protection requirements should be considered. The use of new Energy Absorbing materials will be considered in the future to aid in meeting the requirements (e.g., Pedestrian Protection Shock Absorbing Liquid Packages, etc)

Fixing Selection – When Fixings are selected Pedestrian Protection requirements should be considered. Also the position and direction of the Fixings can be designed at an early stage to have no detrimental effects. (e.g., do not have any hardpoints or sharp points facing in a forward or upward direction)

Manufacturing Feasibility – The theory of solutions to meet the requirements should be backed up with approval from the OEM and Supplier Manufacturing Engineers. Often Panel Design, stampings and assembly Production tooling Manufacturing and Production on line and off line process methods are limited, (due to many factors) and may not be able to manufacture or assemble the required designs.

Additional Engineering Design Work – In theory there should be limited additional Engineering Design as these parts and Systems will be designed anyway on a new vehicle. However it should be considered that most “new” vehicles contain a large percentage of Carry-Over Parts and Systems. These Carry-Over items, if they effect Pedestrian Protection requirements, will have to be redesigned and replaced. The phasing in period for the legislation should allow for this. The Pedestrian Protection requirements should be considered and designed for during the early stages of the Design process. The use of Deformable or Breakaway systems may cause some additional work but examples of these systems are available to use as a basis for any new Designs.

Any parts that have to be redesigned to meet the legislation can potentially be carried over to use on other vehicles which will ultimately reduce their piece costs (but could increase the tooling cost due to the volume increase). It is very difficult to adjust the figures to reflect this without more detailed involvement in the actual designs and knowing what vehicle ranges are involved. However likely candidates to be able to be carried over are brackets, wiper system, headlights (styling permitting) and Underbody BIW. Therefore for this report we can make a statement by advising a percentage decrease in costs by some 15% for the wipers and the headlamp piece prices and tooling costs. These costs have been reduced in this report.

Additional Analysis Work – In theory the only additional Analysis work required is for Pedestrian Impact. Aerodynamic, Cooling and Vehicle Crash Testing will be done anyway on a new vehicle although some additional iterations may be required if the Pedestrian Impact requirements cause any changes.

Additional Test Work – In theory the only additional Test work required is for Pedestrian Impact. Aerodynamic, Cooling and Vehicle Crash Testing will be done anyway on a new vehicle although some additional iterations may be required if the Pedestrian Impact requirements cause any changes.

Active Pedestrian Impact Systems – If it is found that a new vehicle design cannot be packaged to give sufficient Engine Clearance to the Bonnet then an Active Pedestrian Impact System can be considered. This can take the form of the new developments in Pop-up Bonnets, which raise in the event of an impact with a Pedestrian to give additional clearance, or external Airbags. These systems are complimented with additional Sensors on the front of the vehicle to determine a Pedestrian Impact is taking place before activating the systems.

However these systems are new developments and will add significant cost and weight to a vehicle. So they are likely to only be considered in the higher vehicle specification ranges where the cost can be absorbed and where for package reasons the legislation cannot be met within the vehicle design.

8.2.5 *Pop-up bonnets*

The costs for pop-up bonnets shown in Table 8.1 were provided by a vehicle manufacturer who is committed to having a pop-up bonnet system on a forthcoming vehicle, in order to comply with the phase one requirements. The application costs are for testing of the system and for tooling of the system parts. These costs are to be applied through division amongst the vehicles produced in one year and are based on production of about 5,000 vehicles per year.

The costs produced in this section are to be taken as costs for a new vehicle as opposed to costs for modifications to an existing vehicle. As such, it may be considered that any suggested changes may form part of the normal model-replacement cycle. The result of this is that some features mentioned will have no associated pedestrian protection on-cost. For example the vehicle manufacturer concerned suggested that the new bonnet, that would be required for a pop-up bonnet system, would not be expected to be significantly higher in cost than for a 'non-pedestrian compliant' new model bonnet design. Therefore neither the system nor the application costs include a contribution for the bonnet itself, but just for the deployable feature. It should be noted that there is likely to be one-off extra costs around the dates when all vehicles produced have to comply with either phase one (2012) or phase two (2015) of the EC Directive.

Whilst the costs in Table 8.1 from the vehicle manufacturer are assumed to be given with the greatest available level of accuracy because they are close to producing a completely integrated system, it is not possible to say that they are final or verified in any way. This statement reflects the position with the development of pop-up bonnet systems with no complete system released on a vehicle as yet. Therefore the costs are estimated costs for a vehicle with a deployable bonnet. With any process that is incomplete, there may be outstanding issues, the resolution for which could have as yet unidentified and significant extra cost implications.

Table 8.1. Costs for a pop-up bonnet system (from a vehicle manufacturer)

	Annual sales quantity	Cost (€)
System cost (including actuators)	about 5,000 vehicles per year	145.44 per vehicle
Application cost (other than development)	about 5,000 vehicles per year	1,100,000
Development cost (to manufacturer)		4,600,000

9 Review of manufacturing costs

Section 8 has established costs for producing systems on the Landrover Freelander and the Ford Mondeo, for protecting pedestrians, that will address the proposed requirements of phase two of the EC Directive. This section of the report presents the conversion of the system costs from Section 8 into a single cost covering the integration of the pedestrian protection systems into the European vehicle fleet. The relative ease with which the systems from Section 8 are incorporated into the European fleet will vary across the vehicle segments. To address this, it is necessary to consider the change in manufacturing costs when incorporating these systems into a range of vehicles representative of the segments within the European fleet.

It was, therefore, necessary to obtain a breakdown of the European vehicle fleet and this was found from the UK Motor Industry Directory (SMMT, 2003). These data provided the number of new registrations in six European countries, divided into different segments: mini, supermini, lower medium, upper medium, executive, luxury saloon, specialist sports, dual purpose and multi purpose vehicles. For this fleet cost exercise, the mini and supermini segments were grouped together and called supermini, while executive and luxury saloons were grouped together and called executive cars. Dual purpose included both small and large off-roaders, but these were divided into separate segments for this exercise. Similarly, the multi purpose vehicle segment included both small MPV and MPV, and was, therefore, divided as such.

To account for the varying difficulty of including pedestrian protection features within these segments, cars chosen to be representative of each segment were investigated. The vehicles were assessed to determine what combination of the modifications identified for the Ford Mondeo and Landrover Freelander would be needed, on a new vehicle of that segment, to meet the proposed requirements for phase two of the EC Directive.

From the vehicles studied, a list was formulated of the pedestrian protection features that would be needed to make a vehicle of that segment meet phase two of the EC Directive. This list of protection features, or systems, was then compared with the systems and associated costs from Section 8 to give a cost for each segment.

9.1 Cost for a typical vehicle

Whilst some of the system costs provided in Section 8 could be transferred directly, some had to be adjusted. Typical adjustments were for smaller or larger quantities of material, the size of parts to be cut or pressed and therefore tooling costs, whether any existing parts already contributed or could be re-used, and the perceived level of difficulty of incorporating the required modification in to the vehicle. In this way, the cost produced for each pedestrian protection feature was either kept or adjusted for each particular vehicle segment. In every case, this adjustment was based on the justification for the system costs as received from Menard Engineering Limited. In adapting these individual costs to produce European sector costs, some subjective judgments had to be made.

The two vehicles selected by TRL for the detailed cost study by Menard were selected because, between them, they had examples of every type of modification needed to make the fleet comply, with the exception of pop-up bonnets for which the costs were obtained separately. To obtain an appropriate, representative, generic cost for each vehicle sector, the costs of individual features were taken as necessary from either vehicle. For example, although the Mondeo costs did not include a modified wiper spindle, the cost of the Freelander wiper spindle was added to the costs for the Mondeo, along with other adjustments to make a representative, generic large family car segment cost.

The segment costs derived from the manufacturing and tooling costs above will not include the product development cost, therefore an additional allowance was made for this. The additional product development costs can be attributed to Finite Element Analysis (FEA) and validation testing. The FEA costs were to cover the extra numerical simulation time that would be required to tailor the

stiffness of the individual components and behaviour of the impact regions, and finally to check that the pedestrian protection performance was adequate to meet the proposed requirements of phase two of the EC Directive. The validation testing costs were to cover the additional physical testing that would be required, by the manufacturer, to confirm that their vehicle would be approved.

The tooling, assembly, FEA and testing costs provided by Menard Engineering Limited were in the form of one cost, as opposed to a cost per vehicle. Therefore, adjustment of these costs was necessary as the tooling costs for each part could only be given as a cost per vehicle with knowledge of both the typical production run length and number of vehicles produced per year, for that particular segment of the European fleet. A typical number of vehicles produced per model within a vehicle segment in one year were found by taking the mean of the figures given for various models; these data were from vehicle manufacturers in France, Germany, Italy, Spain, Sweden and the United Kingdom (Society of Motor Manufacturers and Traders Limited (SMMT), 2003). With the figure for years in production and number of vehicles produced each year, the tooling or assembly line outlay could be spread over the number of those vehicles that might typically be produced within Europe. This cost per vehicle was then added together with the piece cost per vehicle. The outcome from the investigation of cars was, therefore, to arrive at a cost for making one theoretical, representative vehicle for each of the vehicle segments, meeting the proposed requirements for phase two of the EC Directive. This cost was then factored into the breakdown of the European fleet by segment.

9.1.1 Supermini

It was assumed that the costs required to modify the Ford Mondeo should first be reduced slightly, for this vehicle segment, to take account of it being smaller; therefore a smaller quantity of materials and tooling costs would be necessary to make the same modifications on a smaller size of vehicle. As the supermini segment tends to have exposed wipers, the full costs of the Freelander wiper modifications have then been added. Next, the overall cost has been increased as thought necessary to take account of the extra difficulty with packaging in small cars. No account has been taken of the fact that pedestrian changes are likely to have a more significant effect on the styling of small cars. The estimated increase in cost associated with features for the protection of vulnerable road users for the supermini segment is €46.92 per vehicle.

9.1.2 Small family car

Again, it has been assumed that the costs required to modify the Ford Mondeo should first be reduced, but by a smaller margin than for the supermini, to take account of it being smaller. As the small family car segment tends to have exposed wipers, the full costs of the Freelander wiper modifications have then been added. Next, adjustments were made to reduce the overall cost slightly because packaging issues are thought to be less of a problem in mid-sized cars. The estimated increase in cost associated with features for the protection of vulnerable road users for the small family car segment is €32.68.

It is possible that a pop-up bonnet solution may be more practical for small family car variants with large engines. For a variant such as this, the cost of the pop-up bonnet will have to be on top of all the other modifications, even if it removes the necessity for some of them. Therefore, the estimated cost will be €24.21.

9.1.3 Large family car

The Ford Mondeo costs were taken directly, to provide an initial cost for a large family car. The costs that were provided, introduced the option for inserting either energy absorbing foam between the bumper beam and the bumper fascia, or using a pressed front bumper beam with an additional pressed section in front containing crush initiation folds. The latter of these two options was chosen for the cost for this segment.

In the description of the modifications required for the Ford Mondeo to meet the proposed requirements for phase two of the EC Directive, the justification for not modifying the wiper system is that it is thought already adequate. This is not expected to be a realistic situation for the entire large family car segment and, therefore, it was felt that some allowance for this feature should be made. Therefore, some of the costs for modifying the Landrover Freelander wiper system were factored into the costs for the large family car segment. The resulting estimated increase in cost, through the inclusion of features for protecting pedestrians for the large family car segment, is €38.18.

It is also possible that, for large family car variants with large engines, a pop-up bonnet solution may be more practical. For a variant such as this, the cost of the pop-up bonnet will have to be on top of all the other modifications, even if it removes the necessity for some of them. Therefore, the estimated cost will be €38.05

9.1.4 Executive car

Again, it has been assumed that the costs required to modify the Ford Mondeo should first be increased by a small margin to take account of it being bigger. Whilst it is possible to imagine that some executive cars will have no problems with packaging issues conflicting with the provision of features for the protection of pedestrians, it is thought likely that the combination of large wheels, large engine and streamlined shape will often cause this to be a serious problem. Therefore, the cost for providing protection for pedestrians is expected to be slightly greater than that for a vehicle from the large family car segment and is estimated to be €44.70.

It is possible, for executive cars, that a pop-up bonnet solution may be more practical for some models. For this type of vehicle it is likely that all engine variants of a model will either have a pop-up bonnet or not. If the pop-up bonnet is extended to the side reference lines, it can be made to remove the need for a crushable wing edge and the need to modify many other under-bonnet features will be removed. Therefore, although the pop-up bonnet system will be expensive, savings will be made elsewhere. Taking this into account, the estimated cost will be €38.43.

9.1.5 Roadster

First, the costs came from those for the Ford Mondeo. However, sports cars are almost always so low and streamlined that they do not have to pass the upper legform tests. Therefore, costs associated with this have been removed. The amortized tooling costs will be far higher for sports cars because they are produced in small numbers. These costs have been increased assuming that an average of about 5,000 vehicles per model will be produced each year. For this vehicle segment, the difficulty of passing the headform requirement is very variable, depending on the size and position of the engine and the overall size of the vehicle. If it is assumed that all sports cars can be made to pass without the use of pop-up bonnets, then it is estimated that the additional cost will be €88.77.

With sports cars, as with executive cars, it is possible that a pop-up bonnet solution may be more practical for some models. For this type of vehicle, it is likely that all engine variants of a model will either have a pop-up bonnet or not. If the pop-up bonnet is extended to the side reference lines, it can be made to remove the need for a crushable wing edge and the need to modify many other under-bonnet features will be removed. Therefore, although the pop-up bonnet system will be expensive, savings will be made elsewhere. Taking this into account, the estimated cost will be €406.61.

9.1.6 Small MPV

In many ways, small MPVs are very similar to small family cars and are sometimes based on them, as is the case of the Ford Focus C-Max, which is an adaptation of the Focus car. However, the treatment of the bonnet locking platform and the upper longitudinal rail was more variable. While certain areas, such as the wing edge may be more difficult than in cars, other areas such as the clearance over the

engine may prove easier. Taking these considerations into account, the estimated increase in cost per vehicle for pedestrian protection features is €34.37 for the small MPV segment.

9.1.7 Large MPV

Large MPVs can either be likened to vans or off-roaders. For this exercise, a combination of features from the Mondeo and the Freelander were used, with adjustments to take account of the perceived difficulty for this style of vehicle. In some, the A-pillars are effectively extended to form the upper longitudinal rail and therefore lie very close to the underside of the bonnet and in others the longitudinal is cranked giving a large clearance. Whilst some extra cost has been attributed to the solutions for these problems in these estimates, it is also possible that they could be designed out at the initial design stage. Taking all of these points together, the estimated cost per new vehicle for pedestrian protection features for the MPV segment is €40.25.

9.1.8 Small off-roader

The costs for producing a small off-roader were taken initially from the costs given for modifications to the Landrover Freelander. Again these costs contain an option for using energy-absorbing foam between the bumper beam and bumper fascia or alternatively using a pressed section with crush initiators. For this exercise, the option of using a pressed section was selected.

The Landrover Freelander has a clamshell bonnet design. This feature was thought to make the solutions for the bonnet region and wing edges easier and cheaper than would have been the case for a conventional bonnet design. As the costs for this segment of vehicle should represent all the vehicles contained within it, some of the costs for the wing edge modifications from the Ford Mondeo were also apportioned to the small off-roader segment.

For the purpose of obtaining costs from the investigation of the Landrover Freelander, the full cost of producing a bolt-on spoiler was derived. These costs were then kept for the representative, generic small off-roader. Therefore, the final estimated increase in cost per vehicle is €10.07.

It is thought that a bolt-on spoiler would aid with the force distribution during an impact with a pedestrian leg and hopefully reduce the likelihood of a knee injury occurring. However, a spoiler of the kind for which costs were obtained is not thought to be essential to pass the proposed requirements for phase two of the EC Directive. If a low spoiler with intrinsic load path is not essential to meet the requirements, then consideration should be given to attributing these costs elsewhere, or in fact removing them from the costs for complying with phase two of the Directive. To this end, the estimated pedestrian protection cost is €60.70, for the small off-roader vehicle segment.

9.1.9 Large off-roader

The large off-roader segment was thought to present many of the same issues as the small off-roader segment, with slightly increased materials and tooling costs. These potential cost increases were considered alongside reduced packaging issues. The cost of producing a bolt-on spoiler was transferred from the small off-roader; therefore, the cost of including a bolt-on spoiler has also been included in the entire large off-roader vehicle segment. The final estimated increase for the large off-roader segment is €105.97.

As stated in Section 9.1.8, if a spoiler is not considered as essential to the proposed requirements for phase two of the EC Directive, then it may be desirable to provide costs with those for the spoiler removed. The estimated pedestrian protection cost for the large off-roader vehicle segment with no bolt-on spoiler is €55.70.

9.2 Breakdown of the European fleet

The additional cost per vehicle for a representative, generic vehicle of each segment has been estimated above in Section 9.1.

As the breakdown of new registrations into vehicle segments that was given by SMMT was only for six countries, it was necessary to obtain the breakdown for the 25 member states of the EU. However, these data could not be found but the total number of new registrations recorded in each of the countries within the EU for the year 2003 is available from ACEA. These figures are presented in Table 9.1. Unfortunately, figures were not available for Cyprus or Malta so the number of new registrations in these countries was estimated from their population and estimated vehicle ownership. To obtain the breakdown of vehicles into the seven segments identified above for the remaining 19 countries, the distribution of new registrations by segment was likened to that of a similar country of the six where it was available. The country selected as similar was chosen on the basis of geography and GDP (Gross Domestic Product) per capita. The estimated distribution of segments for each of the European member states is shown in Table 9.1. The way that vehicles are categorised does vary from country to country, hence in some cases zeros appear in the table when one type has been included under another type in that country. Simple addition of the number of new registrations per segment from each country considered gives a total figure. The total new registrations in Europe for each segment are also shown at the bottom of Table 9.1.

If it is assumed that vehicles will continue to be produced in these numbers with the same distribution by segment, the yearly cost for pedestrian protection in future years, when phase two has come into force, can be calculated. The cost can be calculated for each segment using the representative, generic cost per vehicle for each segment (Section 9.1), multiplied by the number of vehicles produced in that segment, given in Table 9.1. The segment costs have then been summed to produce the total yearly pedestrian protection cost.

Table 9.1. Breakdown of the European new passenger car registrations by country and vehicle segment

Country	Supermini	Small family car	Large family car	Executive car	Sports car	Off-roader	MPV	Total new registrations
Austria	86,776	89,993	88,153	9,806	358	25,036	0	300,121
Belgium	170,816	156,664	64,608	35,107	4,928	13,915	12,758	458,796
Cyprus	5,921	5,142	2,254	112	446	1,128	435	15,438
Czech Republic	58,670	50,954	22,341	1,107	4,417	11,177	4,316	152,981
Denmark	27,782	28,812	28,223	3,139	115	8,015	0	96,085
Estonia	5,984	5,197	2,278	113	450	1,140	440	15,602
Finland	42,567	44,145	43,243	4,810	175	12,281	0	147,222
France	748,068	686,094	282,945	153,748	21,583	60,938	55,871	2,009,246
Germany	1,100,558	973,897	637,665	157,293	75,895	173,716	117,914	3,236,938
Greece	98,674	85,698	37,574	1,862	7,428	18,798	7,258	257,293
Hungary	79,933	69,422	30,438	1,508	6,017	15,228	5,880	208,426
Ireland	49,417	43,730	28,632	7,063	3,408	7,800	5,295	145,345
Italy	1,122,084	434,597	232,195	86,647	14,782	107,341	251,980	2,249,626
Latvia	3,342	2,902	1,272	63	252	637	246	8,713
Lithuania	2,893	2,512	1,102	55	218	551	213	7,543
Luxembourg	16,240	14,895	6,143	3,338	469	1,323	1,213	43,620
Malta	4,285	3,116	1,503	243	0	0	121	9,268
Netherlands	182,004	166,926	68,840	37,407	5,251	14,826	13,593	488,848
Poland	137,462	119,385	52,344	2,594	10,348	26,187	10,111	358,432
Portugal	87,745	63,809	30,776	4,982	0	0	2,481	189,792
Slovakia	22,912	19,899	8,724	432	1,725	4,365	1,685	59,742
Slovenia	27,530	20,020	9,656	1,563	0	0	778	59,548
Spain	689,831	267,180	142,748	53,269	9,088	65,991	154,911	1,383,017
Sweden	75,524	78,324	76,723	8,534	311	21,789	0	261,206
United Kingdom	876,876	775,958	508,063	125,324	60,470	138,409	93,949	2,579,050
Total	5,723,892	4,209,271	2,408,443	700,119	228,132	730,592	741,448	14,741,898

9.3 Costs for different combinations of solutions

Costs for various different permutations of solutions are presented in the following sections. These costs are calculated by replacing the standard cost given in Section 9.1 with the alternative cost given under a segment, where one is available. Whilst none of the following combinations is expected to match the real fleet distribution of solutions, it is thought that the real cost is likely to lie within the range of figures in Table 9.2. Of these, it is thought that the cost for having bolt-on spoilers fitted to all of the off-roader segment and pop-up bonnets fitted to all sports cars and executive cars is likely to be the most appropriate for the fleet, despite it almost certainly not representing the real distribution of solutions.

9.3.1 Whole fleet protected without the use of deployable systems

A total cost, assuming that no deployable solutions are used in any of the vehicle segments, was produced using the method described above. Although unlikely, it was thought this cost may be of interest. A total annual fleet (i.e. new registrations) cost for providing pedestrian protection for this option will be €660 million.

9.3.2 Deployable bonnet

In Section 9.1, the option of using a pop-up bonnet system was introduced for the small family car, the large family car, the executive car and sports car segments. The costs for this option have been estimated to be significantly greater than those for providing solutions without resorting to the pop-up bonnet option. Therefore, should vehicle manufacturers choose pop-up bonnet systems, the total annual fleet cost for providing pedestrian protection will increase.

It is expected that some vehicles within the specialist sports segment will use pop-up bonnets in approximately one year's time. It is thought that the sports cars, executive cars and hot hatchback models are the most likely to opt for pop-up bonnet systems but these systems will not be universally adopted throughout any of the segments. To give some estimates of the costs of using this more expensive solution, various combinations have been calculated, however for simplicity these have been applied to whole segments. These combinations and their costs are given in Table 9.2.

9.3.3 Attribution of the costs for bolt-on spoilers

It is thought that the addition of a spoiler to dual-purpose vehicles for use on roads would significantly increase fuel economy and stability through better management of the air flow underneath the vehicle. Therefore, it is possible that the cost of providing a removable spoiler for off-road vehicles may be recovered by this and should not be attributed to pedestrian protection. Even a small increase in fuel economy when considered over the lifetime of the vehicle would produce large financial savings for the owner. Additionally, greater stability may prevent accidents from occurring and has the potential to save lives of both occupants and vulnerable road users. With consideration given to both or either of these features, it may be that the addition of a deployable or detachable spoiler provides its own justification, for use on roads.

To investigate this, the costs for the small and large off-roader vehicle segments with the spoiler costs removed were estimated and were presented in Sections 9.1.8 and 9.1.9. These revised off-roader costs were used in the re-calculation to determine the complete European vehicle fleet costs, re-calculated for the case where no bolt-on spoilers are used. The effect of this was to reduce the annual cost (for new registrations) to €620 million.

9.3.4 Deployable bonnets and no off-roader spoiler costs

The costs for four degrees of vehicle manufacturers shifting towards the use of pop-up bonnet systems were presented in the top part of Table 9.2. These costs assume the use of pop-up bonnet systems in the segments listed, as well as the costs for spoilers on off-roader vehicles. Further cost combinations are presented in the lower half of this table where the costs for pop-up bonnet systems are included but the costs for spoilers within the off-roader segment are not.

Table 9.2. Annual new registration costs for the different combinations of solutions for the EU

Spoiler option	Pop-up bonnet option	Cost (€million)
Bolt-on spoilers fitted to all of the off-roader segment and the costs attributed to pedestrian protection	No pop-up bonnets	660
	Pop-up bonnets fitted to all sports cars	730
	Pop-up bonnets fitted to all sports cars and executive cars	795
	Pop-up bonnets fitted to all sports, executive and large family cars	1,035
	Pop-up bonnets fitted to all sports, executive, large family and small family cars	1,420
No costs for fitting a spoiler to the off-roader segment attributed to pedestrian protection	No pop-up bonnets	620
	Pop-up bonnets fitted to all sports cars	695
	Pop-up bonnets fitted to all sports cars and executive cars	760
	Pop-up bonnets fitted to all sports, executive and large family cars	1,000
	Pop-up bonnets fitted to all sports, executive, large family and small family cars	1,385

Note: The cost in the shaded row is thought likely to be the most appropriate for the fleet, despite it almost certainly not representing the real distribution of solutions.

10 Cost benefit analysis

The intention of this section is to quantify the relative costs and benefits of vulnerable road user protection, with particular emphasis on the effects of proposals made in Section 7.4.1 of this study. Vulnerable road users are those liable to be impacted in road accidents without having the benefit of a protective vehicle structure around them. This applies mainly to pedestrians and pedal cyclists, and, to a lesser extent, motorcyclists. In this study only benefits to pedestrians and pedal cyclists have been considered. Nevertheless, there will be some added benefit for motorcyclists.

Three vulnerable road user protection 'options' are considered. All three take as a baseline (i.e. zero benefits) the standard of protection provided by current cars that have been designed with virtually no consideration given to the protection of vulnerable road users. This therefore applies to the vast majority of current car designs, as those designed with significant consideration of vulnerable road users are currently the exception. One option considered is that currently specified in phase two of EC Directive 2003/102/EC (European Parliament and Council of the European Union, 2003). However, no costs have been determined for this option so only benefits will be presented. As this option uses the EEVC WG17 test procedures and acceptance levels it is typically referred to here as 'EEVC', particularly in tables. The second option is the protection that would be offered if the package of relaxations to the current Directive that are proposed in this study (see Section 7.4.1), on technical and feasibility grounds, were to be accepted. The third option considers the benefits that would be obtained by combining that same package of relaxations with the addition of brake assist systems on cars. No costs have been provided to TRL for brake assist systems, so they are taken here as having negligible cost, since much of the hardware is shared with anti-locking braking systems and manufacturers are likely in many cases to be fitting them voluntarily to improve occupant and vehicle protection.

In vehicle terms the scope should be that of the EC Directive 2003/102/EC, which applies to M1 (passenger cars) & N1 (vans) derived from M1, in both cases for vehicles of less than 2½ tonnes. In practice it is difficult to identify those hit by car-derived vans in the accident statistics, so only cars and taxis are considered. However, vehicle sales data have been obtained on a similar basis, so the effect of this exclusion on the cost to benefit ratio will be minimal.

In geographical terms the scope of the study is to obtain costs and benefits for the recently enlarged European Union, i.e. the EU-25. In some cases only very limited or no data were available, so where necessary estimates have been made to fill the gaps.

While data for the EU-25 have been used to get the correct casualty numbers and vehicle sales, in most other cases data from British sources has been used to get the correct proportions. This is more easily available to the authors and is more familiar to them, and in general it is of high quality. Searching for comparable data from other countries would have been time consuming and in many cases would only have been available from a few countries to a comparable standard. Using British data has also improved consistency, in that for example most of the vehicle costs were provided in UK pounds, as are the casualty costs, so the calculated cost to benefit ratio would not be subject to fluctuations as exchange rates vary. In terms of casualty injury severities it is also an advantage to be using the same definitions of seriously and slightly injured casualties for accident data as for casualty costs.

There have been a number of previous benefit studies and full cost-benefit studies looking at the effect of pedestrian test proposals, particularly of the EEVC test procedures. TRL (Lawrence *et al.*, 1993) carried out a cost benefit study looking at earlier EEVC test proposals developed by EEVC WG10. The Motor Industry Research Association (MIRA) was commissioned by the EC to carry out another cost-benefit study (Davies and Clemo, 1997; Davies, 1998). Some of these studies have also estimated benefits to pedal cyclists. The European Transport Safety Council's (ETSC) estimate (2000) included pedestrians and pedal cyclists, and included allowances for under-reporting of accidents. TRL also carried out a study to look at the benefits from implementation of test procedures being developed by the International Harmonized Research Activities (IHRA) pedestrian safety working group. A summary of this study was included in a

conference paper by the IHRA working group (Mizuno and Ishikawa, 2001), and full details are in the working group's report (IHRA Pedestrian Safety Working Group, 2001). Most recently, TRL (Lawrence *et al.*, 2002) studied costs and benefits to compare the EEVC WG17 test procedures with those of a proposed Negotiated Agreement between the EC and ACEA, which was a precursor to the very similar requirements of phase one of the Directive, 2003/102/EC (European Parliament and Council of the European Union, 2003).

The current study by TRL has a similar methodology to the study for the IHRA working group (Mizuno and Ishikawa, 2001; IHRA Pedestrian Safety Working Group, 2001) and the study of the protection offered by the Negotiated Agreement (Lawrence *et al.*, 2002), and again makes use of the IHRA pedestrian accident dataset. The principle differences from the latter study are:

- The current study is a full costs and benefits study, with estimates of cost to benefit ratios.
- The options primarily being considered are different, though the 'EEVC' option is in common.
- The current study includes benefit for pedal cyclists.
- The current study allows for under-reporting of accidents in national statistics.
- Allowances are made for the manufacturers' margin in the current study. Manufacturers typically aim to achieve test results that are about 80 percent of the acceptance criteria, so that they have reasonable confidence of achieving passes in the test. They also need to have a little extra crush depth for the same reason.

Car-to-pedestrian impacts are extraordinarily complex events, with the outcome dependent on many factors. These factors include impact speed, shape of car, pedestrian age and size, pedestrian trajectory, stiffness of impacting parts of car, strength of impacted parts of the pedestrian. Some of the variables involved, such as injury risk distributions, are poorly understood at the present time. The purpose of this calculation is to estimate the benefits obtained with the options in a way that best reflects the potential real-world situations.

The benefit calculation uses historical accident data to estimate the effect on future accidents that would be expected to occur from implementation of one of the current test proposals. In looking at historical data the estimate obtained is of casualties that would not have been injured at that severity had the cars that hit them met the standards required by the test proposals. Though not strictly accurate, in what follows these will normally be referred to as casualties 'saved'.

10.1 Overall methodology of cost benefit study

In discussing the methodology it can be useful to work back from the final result. In a cost benefit calculation the main result would typically be a cost to benefit ratio, which can be used to decide whether the benefits would justify the costs, in this case the benefits in casualties saved against the costs of making cars safer. This therefore requires that both costs and benefits be quantified in financial terms.

In this study costs have already been presented in Sections 8 and 9, with costs for different vehicle options. See in particular Table 9.2. In this section they will be converted to consumer costs, which are the costs seen by the end purchaser of the car.

The financial benefits are obtained by estimating the number of casualties that might be saved, and then multiplying by a 'casualty cost'.

The estimate of the casualties saved in turn consists of two factors, the numbers of vulnerable road users currently being killed and seriously injured, and the estimate of the proportions of casualties that could in the future be saved with safer car fronts.

The estimates of the proportions of current casualties that could be 'saved' are derived from a chain of estimates, starting with all the vulnerable road users fatally or seriously injured. A proportion of these will be injured by vehicles within the scope of the test procedures, mainly by cars. Of these, a

proportion will be injured by the impact type that the test procedures are simulating, namely a frontal impact. Of these, a proportion will be injured within the impact speed range covered by the test procedures. Of these, a proportion of injuries will be caused by the tested area of the vehicle rather than by untested areas on the car (A pillars, etc.) or by the ground. This process is shown in Figure 10.1. Some of these stages can be combined, depending on the data available.

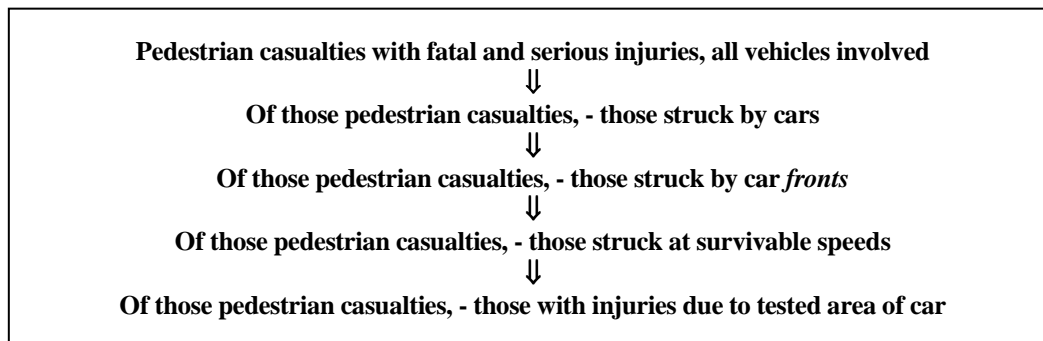

Figure 10.1. Proportion of pedestrian casualties potentially saved

The calculations are split into a number of parallel strands, such as for fatalities and serious casualties, pedestrians and pedal cyclists, and for the different test proposals.

10.2 Calculations and results

10.2.1 Vulnerable road user casualties in the European Union

These benefits will be estimated for fatalities and for serious casualties. Whereas the definition of a fatality is fairly consistent internationally, there is no generally accepted definition of what constitutes a serious casualty. The test procedures are intended to prevent most fractures, joint injuries and internal injuries, including brain injuries, i.e. most AIS 2+ injuries. This corresponds well to the definitions of serious casualties used by the UN Economic Commission for Europe (ECE) and by the UK. Estimates made here of the proportion of serious casualties saved will therefore correspond to these definitions. The numbers of current EU serious casualties to these definitions will also be estimated, to avoid the problems of variable definitions and reporting rates in the statistics available from the countries of the EU. Finally, the estimates of financial benefits will use UK casualty costs; the UK serious casualty cost will correspond to the UK serious casualty definition.

Estimates of the potential changes in slight casualties due to cars passing the test procedures are not made in this study. These injuries would typically be bruises, cuts and abrasions, and the test procedures are not designed and are not expected to reduce the frequency of them.

Data on pedestrian and pedal cycle fatalities by country are available from the International Road Traffic and Accident Database (IRTAD) (Brühning and Berns, 1998) and the Community database on Accidents on the Roads in Europe (CARE) database. It was possible to download the required data for most of the EU-25 countries from one or the other of these organisations' websites. For the remaining countries data were available of fatalities of all road user types. Missing pedestrian and pedal cyclist data were estimated by using proportions from countries of similar geography and / or economic position. The fatality data that were obtained and estimated are shown in Table 10.1. The data are for the latest available year for each country. These data have already been standardised by IRTAD or CARE to the generally accepted death within 30 days definition of fatality.

Table 10.1. Pedestrian and pedal cyclist fatalities by country for the European Union (EU-25)

Data obtained from the IRTAD and CARE websites. Pedestrian and pedal cyclist fatalities for countries marked * were estimated from figures for all road users.

Country	Pedestrians	Pedal cyclists	Country	Pedestrians	Pedal cyclists
Austria	160	80	Latvia *	120	60
Belgium	158	128	Lithuania *	162	80
Cyprus *	20	3	Luxembourg	6	0
Czech Republic	309	160	Malta *	3	1
Denmark	64	52	Netherlands	97	169
Estonia *	52	26	Poland	1,987	681
Finland	40	53	Portugal	339	58
France	866	223	Slovakia *	132	68
Germany	873	583	Slovenia	41	18
Greece	338	29	Spain	776	96
Hungary	377	182	Sweden	58	37
Ireland	86	18	United Kingdom	808	133
Italy	846	365	Total	8,718	3,303

Serious casualties in the EU were not taken from the international databases because of varying definitions and reporting rates. It was considered that more reliable estimates could be obtained by multiplying the number of pedestrian and pedal cyclist fatalities in the EU by the GB ratio of pedestrian serious casualties to fatalities. However, it was also realised that this ratio varied widely with pedestrian age, and GB has a high proportion of child casualties. The estimates of EU serious casualties were therefore obtained by estimating separately over a number of age bands and then summing them, to give age-weighted estimates of seriously injured casualties. These estimates for pedestrians and pedal cyclists are given in the top row of Table 10.2.

However, these numbers were still estimates of the 'official' casualty numbers that would have been reported in national statistics. Various studies have shown that casualties are under-reported. This effect can be split into casualties not being reported to the police, the police not recording reported casualties in the national statistics and the wrong severity class being attributed to casualties.

Table 10.2. Estimates of European Union (EU-25) pedestrian and pedal cyclist fatalities and seriously injured casualties, without and with an allowance for under-reporting

	Pedestrians		Pedal cyclists	
	Fatalities	Serious	Fatalities	Serious
Without allowing for under-reporting	8,718	74,746	3,303	48,828
With under-reporting adjustment	9,024	176,385	3,418	115,224

Jacobs *et al.* (2000) reviewed a number of studies on under-reporting. Even in the developed world some countries have high under-reporting rates of fatalities (for all road user types). In Italy the numbers obtained from death certificates were 26 percent higher than those from police statistics. Others values from a variety of studies were Spain 3 percent, Switzerland 2 percent, Western Australia 5 percent, USA 2 percent, Germany 5-9 percent. In their estimates Jacobs *et al.* updated

fatalities in highly motorised countries (HMC) by 2 to 5 percent, in addition to any 30-day adjustments. Accordingly, the fatality estimates for the EU-25 have been increased in the current study by the middle of that range, 3.5 percent.

Simpson (1996) gave adjustment factors for Great Britain for pedestrians (serious 2.28 and slight 1.35) and pedal cyclists (serious 5.73 and slight 2.35). Seriously injured casualties have a higher under-reporting rate than slightly injured casualties because many seriously injured are wrongly recorded as being slightly injured. Pedal cyclist adjustment factors are higher mainly because many single vehicle accidents (i.e. pedal cycle only) are un-reported. Therefore, for the current study looking at accidents involving cars, it was more realistic to use lower adjustment factors for pedal cyclists and therefore the pedestrian adjustment factors were also used for pedal cyclists.

Since the seriously injured casualties in the EU-25 are estimated from fatalities, both the 1.035 and 2.28 factors were applied to the seriously injured casualty estimates. The final estimates of fatalities and seriously injured casualties are shown in the bottom row of Table 10.2.

10.2.2 Proportions hit by car fronts

The proportions of fatally and seriously injured pedestrians and pedal cyclists that were hit by cars and car fronts were obtained from the national statistics of Great Britain, for accident years 1997-2001. See Table 10.3. Casualties hit by taxis were included, but it was not possible to identify those hit by car-derived vans (these vehicles are covered by the test proposals). The statistics record the first point of contact, so casualties were included for which this was 'front'. The proportions hit by car fronts are used in the further analysis; the proportions for cars are given here for information, as they allow the proportions of casualties hit by cars that are 'saved' to be estimated.

Table 10.3. Proportions of pedestrians and pedal cyclists by severity that were hit by cars and car fronts in Great Britain

		Fatal	Serious	Slight
Proportions hit by cars	Pedestrians	0.71	0.83	0.84
	Pedal Cyclists	0.55	0.81	0.87
Proportions hit by car fronts	Pedestrians	0.60	0.56	0.50
	Pedal Cyclists	0.44	0.45	0.44

10.2.3 IHRA pedestrian accident dataset

The proportions of casualties hit at survivable speeds and by the tested area were obtained by analysis of the International Harmonized Research Activities (IHRA) pedestrian accident dataset. The IHRA Pedestrian Safety Working Group had gathered much of the most recent in-depth on-the-spot pedestrian accident data available for Germany, Japan, USA and Australia. However, at the time of the study by TRL for IHRA the Australian data were not available. Moreover, for the IHRA study TRL had to make considerable efforts to obtain extra data on fatalities and to convert the dataset into a relational database structure. Therefore, the current study again uses the dataset prepared for that study, without the Australian data. This dataset contains data on 1535 casualties, of which 155 were fatalities, 732 were serious casualties and 648 were slight casualties. By country the split is Germany 782 casualties, Japan 242 casualties and USA 511 casualties. The useable dataset tends to be a little smaller than this as some information is missing or uses 'unknown' codes. The accident cases are all of pedestrians hit by the fronts of cars. The accidents are from years 1985 to 1998, with the mean accident year being 1993 and the median accident year 1995. Among other information, the dataset has impact speeds, casualty ages and, for the injuries suffered, AIS, body region and area of the

vehicle causing the injury. The cumulative impact speed distribution by casualty severity is shown in Figure 10.2. Further information on the IHRA pedestrian accident dataset is available from a conference paper (Mizuno and Ishikawa, 2001) and a full report by the working group (IHRA Pedestrian Safety Working Group, 2001). Further references to the IHRA pedestrian accident dataset here refer to the more detailed dataset as developed by TRL.

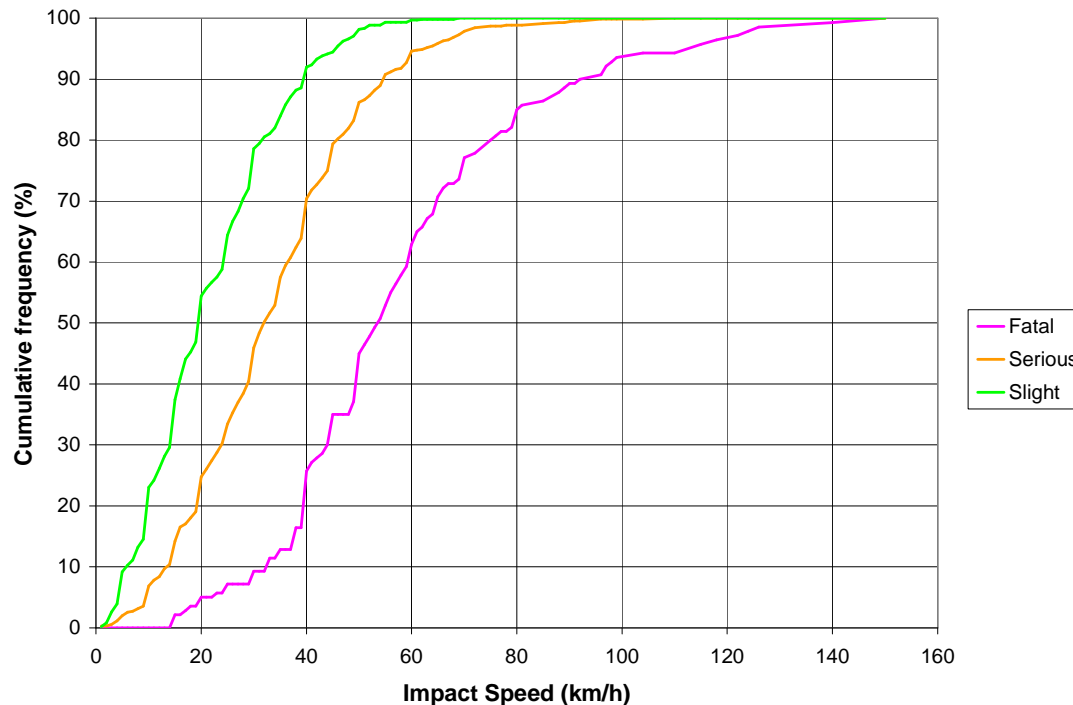

Figure 10.2. Cumulative impact speed distributions, from the IHRA pedestrian accident dataset, by casualty severity

10.2.4 Injury risks

The proposed package of relaxations was specified in Section 7.4.1. The differences between the current phase two requirements and the proposed relaxations need, as far as possible, to be converted into a method for estimating the likely benefits. The previous TRL study (Lawrence *et al.*, 2002) was able to compare test procedures with different test speeds, so discrimination between the test procedures was primarily on the basis of speed. However, with the current study only the brake assist effect can easily be converted into a speed effect. The principal changes proposed with the package of relaxations are increases in the acceptance criteria. The second major set of changes proposed was the nominated relaxation zones.

It was decided to use an injury risk method to discriminate between the two test procedure options. Most acceptance criteria are correlated with a risk of injury. If a test point gives a certain reading then this can be used to estimate the risk of injury to someone contacting the same point at an equivalent speed. There is normally an injury risk curve from which injury risk can be read off against the test output. For the legform tibia acceleration and knee bending angle criteria the injury risk curves of Matsui (2003) were used, see Figure 3.8. For each acceptance criteria it was assumed that the average test output would be at the manufacturers' target value, which is normally set at 80 percent of the acceptance criteria. Therefore, for each acceptance criteria the injury risk was obtained for an output at 80 percent of the acceptance criteria. For the upper legform, force and bending moment injury risk curves by Rodmell and Lawrence (1998) were used; these also appear in the European Enhanced

Vehicle-safety Committee report (1998). For the headform, an injury risk curve by Mertz (1993) was used. The injury risks obtained are shown in Table 10.4.

Table 10.4. Injury causing parameters, acceptance criteria proposed and injury risks used in the analysis based on manufacturer's targets at 80 percent of the acceptance criteria

Test tool and parameter	EEVC		Proposal: main area		Proposal: relaxation area	
	Acceptance criteria	Injury risk	Acceptance criteria	Injury risk	Acceptance criteria	Injury risk
Legform, knee bending angle	15°	5.4%	19°	10.2%	19°	10.2%
Legform, tibia acceleration	150 g	9.0%	190 g	18.9%	250 g	48.3%
Upper legform, sum of forces	5 kN	10.3%	6.25 kN	20.2%	7.5 kN	36.8%
Upper legform, bending moment	300 Nm	11.8%	375 Nm	18.3%	510 Nm	40.3%
Headform, HIC	1000	7.0%	1250	15%	2000	64%

No allowance was made for the reduced upper legform test energies or the reduced energy cap, as this would have added even more complexity to the calculation. Likewise, deploying systems such as pop-up bonnets were not considered; for calculation purposes they were taken as being no different to non-deploying systems.

10.2.5 Brake assist systems

Brake assist systems (BAS) are described in Section 4.1.2.1. There are some published papers on the benefits of BAS but none have been published that deal specifically with the benefits for vulnerable road users. However, ACEA (2004a) were able to supply limited details from a study that hasn't yet been published. This uses German In-Depth Accident Study (GIDAS) data. See Figure 10.3. The study looked at well documented accidents and was able to estimate on a case-by-case basis whether a BAS would have been activated and if so what effect it would have had in reducing impact speed. Their intention is to use the same data to estimate benefits directly in injury reduction. However, for TRL's purposes some measure of speed reduction was required, to interface with the rest of the analysis. It must be accepted that this is a rudimentary way of proceeding, and it is likely that the ACEA / GIDAS study will eventually produce much more reliable results.

From the graph provided (Figure 10.3) it wasn't possible to obtain a clear indication of the benefits provided. The distribution is skewed towards the lower reductions in speed. The speed changes in the accident avoided cases were not specified, but given the skewed distribution it seemed likely that they tended to be quite low. The cases shown were part of a sample of 712 that were analysed. The remainder were presumably cases where there was no pre-impact braking. Any estimate of effectiveness has to consider that BAS will only reduce speeds in a proportion of cases, those where the driver has initiated braking. Taking the centres of the ranges quoted, assuming that the accident avoided cases had initially averaged 5 km/h (given the skewed distribution) and allowing for the no-braking cases, allowed a very rough estimate of an average speed reduction of 2 km/h to be made, for the effect of brake assist, in all car frontal pedestrian accidents. This was applied to the cost benefit analysis, by allowing the test procedure options to provide protection at impact speeds 2 km/h faster than otherwise. However, given the uncertainties in this value, the results must at best be regarded as no more than 'indicative'.

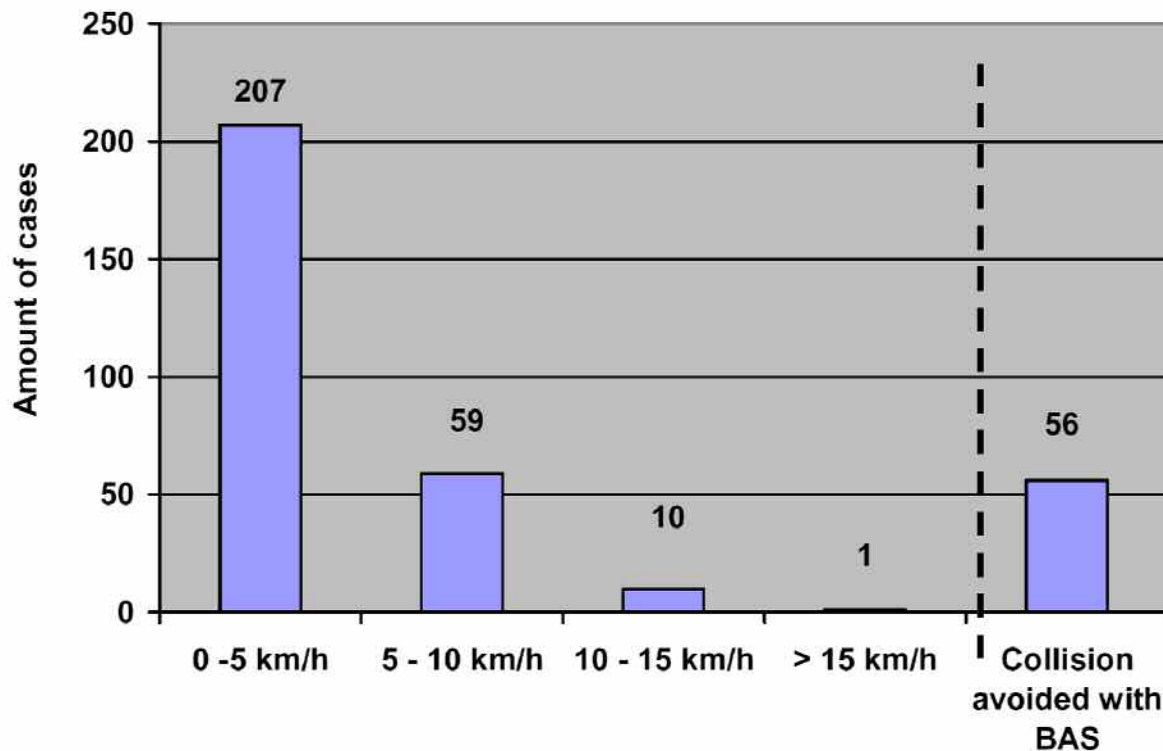

Figure 10.3. Benefit of brake assist systems (BAS) by speed reduction or accident avoidance (ACEA, 2004a)

Subsequent to this cost benefit analysis a further communication was received from ACEA (2004b). This included an additional graph, Figure 10.4, which shows estimates for potential speed reductions in individual cases, due to BAS, banded by the original car impact speed. ACEA also stated that the average original impact speed of the accident avoided cases was 13 km/h, rather than the 5 km/h assumed by TRL above. Substituting this value in the above estimation gives an average speed reduction of 5.5 km/h in cases where there was some benefit; it can be seen that this estimate is consistent with Figure 10.4, given that the cases tend to overlap much more at low speed reductions. When the average speed reduction is estimated over all cases, whether they are cases with any BAS benefit or not, the average speed reduction is now 2.6 km/h. This is not a significant increase from the 2 km/h value used in the benefit calculation. Moreover, it can be seen in Figure 10.4 that the average benefits in terms of speed reduction are relatively low in the 40-50 km/h band. This is to be expected, as the majority of pedestrians accidents will occur in urban areas, with a typical speed limit of 50 km/h. Most vehicles will initially be travelling at around or slightly over the legal limit. Those that have impacted at speeds of 40-50 km/h will therefore tend to be those where there has been relatively little braking before impact. It follows that the benefits of BAS in terms of speed reduction will similarly be relatively low in this speed band. Unfortunately, since the test procedures are designed to provide relatively high levels of safety up to about 40 km/h, with relatively poor safety at higher speeds, it follows that brake assist systems are a poor complement to the pedestrian test procedures. Reductions in impact speeds, due to BAS, at speeds well below 40 km/h will tend not to have major benefits since most casualties should survive even without the BAS benefit. Also, at higher speeds, casualties may be injured or killed even if BAS reduces the impact speed. The range of speed around 40 km/h will be where a reduction in impact speeds could have the greatest benefit, but is the speed range where BAS average speed reductions seem to be at a minimum. Given this factor, the 2 km/h assumed benefit for BAS over the whole speed range should give about the right level of benefits for BAS, in terms of injury reduction.

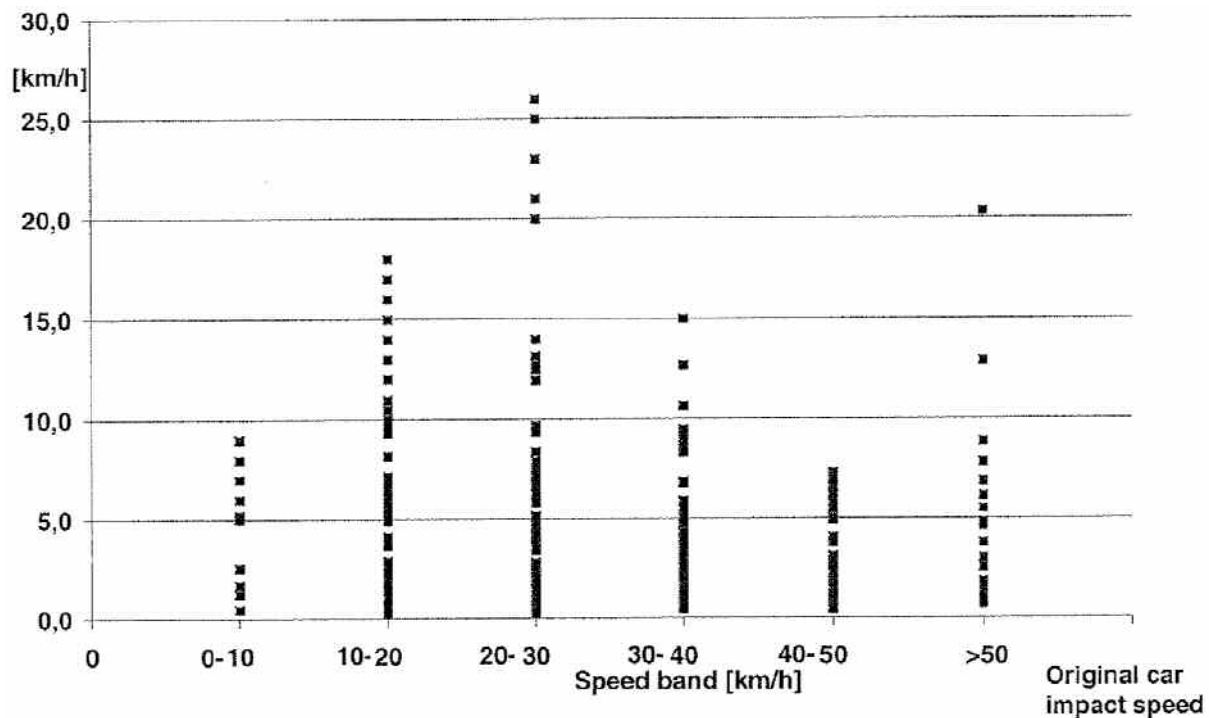

Figure 10.4. Possible speed reduction due to BAS, by original car impact speed (ACEA, 2004b)

10.2.6 Methodology for proportions hit at survivable speeds

The test proposals are designed to provide protection up to a certain speed or speeds. At very high pedestrian impact speeds little difference would be expected, as the car would be crushed beyond the depth to which it would be crushed in the approval tests, and the pedestrian kinematics and head impact locations would be different. The impact speeds of different phases of pedestrian impacts in relation to the initial speed of the car are reflected in the sub-system test speed, which may not be the same as the car impact speed. For the purpose of the calculation, what matters is the 'equivalent car speed', not the test speed. Clearly, there will be a range of speeds over which the test procedures may or may not provide protection in each individual accident. However, a basis is required for estimating the average benefit over the whole range of accident cases.

In previous studies two very different methods were used to calculate the proportion of injured casualties hit at speeds at which the test procedure could protect them: a) A simplified assumption that those casualties prevented above the equivalent car impact speed will match those casualties not prevented below. b) An assumption that the safety measures will shift the distribution of the relative proportions of fatalities, seriously injured casualties and slightly injured casualties upward in impact speed. The first assumption was used by TRL (Lawrence *et al*, 1993), and the second by MIRA (Davies and Clemo, 1997). TRL used both assumptions in parallel calculations in the IHRA study (Mizuno and Ishikawa, 2001) (IHRA Pedestrian Safety Working Group, 2001) and also in their more recent study (Lawrence *et al.*, 2002). Both are again used in the current study, although with some modifications.

The two different assumptions and methods are illustrated in Figure 10.5. Figure 10.5a is an idealised 'current' speed and severity distribution created to show the methods; it does not correspond to any real data set. However, it can be seen that few accidents occur at high speeds, and higher severity accidents are less frequent and peak at higher speeds. At very low speeds most accidents result in slight injury and at very high speeds virtually all are fatal.

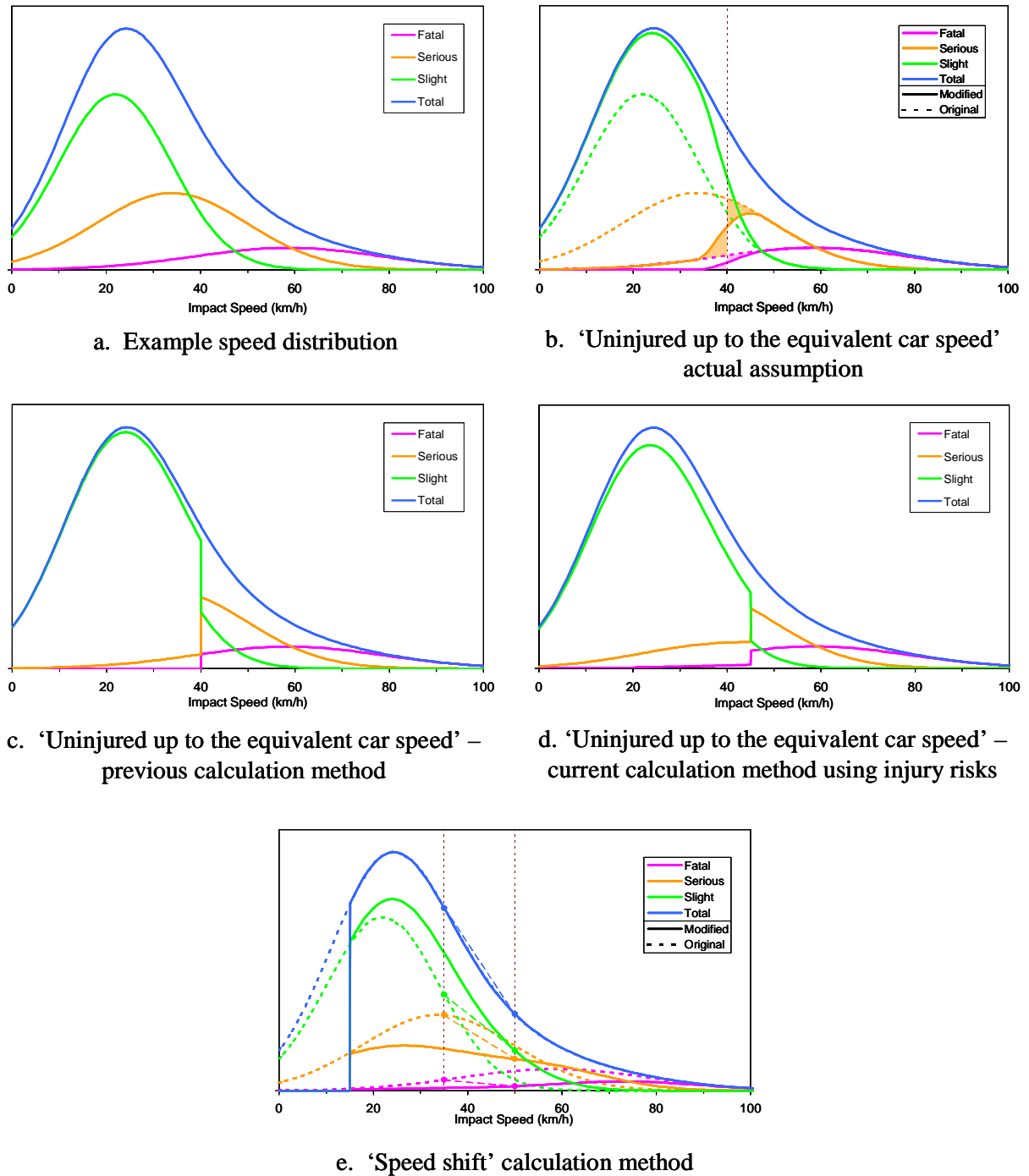

Figure 10.5. Example speed distributions: before pedestrian protection, assumed distribution with pedestrian protection and ‘uninjured up to the equivalent car speed’ calculation methods, and ‘speed shift’ calculation method

Figure 10.5b shows how this speed distribution is likely to be modified with implementation of the pedestrian protection Directive. Note that for clarity only cases that involve the front of cars, where the injuries have been caused in the original scenario by parts of the car that will be tested, are considered here. For the casualty to be ‘saved’ the impact also has to be at a survivable speed, and the impact forces must not exceed the strength of the pedestrian. Since these forces will also be a function of speed, there will be a rapid reduction in the numbers of fatally and seriously injured casualties below the equivalent car speed. However, some weak or unlucky casualties will still be

injured at speeds below the equivalent car speed and some strong or lucky casualties will be ‘saved’ at speeds above the equivalent car speed. These are shown shaded in Figure 10.5b. Note that no benefit has been assumed for slight casualties as the test procedures are not designed to prevent such minor injuries. Also, note that fatalities ‘saved’ are assumed to still be seriously injured and serious casualties ‘saved’ to still be slightly injured.

In the previous two studies by TRL the assumption used for the ‘uninjured up to the equivalent car speed’ calculation method corresponded to that shown in Figure 10.5c. All fatalities and seriously injured casualties hit at speeds up to the equivalent car speed of the test procedure are taken to be ‘saved’, provided the injuries were caused by areas of the car that will be tested by the test procedures. However, it isn’t reasonable to assume that most fatalities could be converted to slight injuries or none. It is more likely that they would still be seriously injured. Similarly, it is more likely that existing serious casualties will still be slightly injured. The effect of these assumptions can be seen, with the serious distribution following the original fatality distribution at speeds below the equivalent car speed and the slight distribution increasing to maintain the original total distribution. However, the abrupt transition at the equivalent car speed was only a working assumption, made for ease of calculation.

It was explained in Section 10.2.4 that the current study needed to use injury risks to calculate the difference between the benefits of the current and proposed phase two requirements. The calculation method is shown in Figure 10.5d. The proportion of fatalities and seriously injured casualties saved at lower speeds is for ease of calculation taken to be fixed, although the proportions will be different for the two different test procedure options. At higher speeds the assumption is again of no casualties saved. However, since the risk of injury in the calculation was no longer taken to be zero at speeds below the equivalent car speed, some method was needed to get back the casualties ‘saved’ in compensation at speeds above the equivalent car speed. It was therefore decided to increase the equivalent car speed for calculation purposes. Some test runs of the database analysis program were performed to obtain a speed addition that was equivalent to the previous method, of assuming for calculation purposes a zero injury risk below the equivalent car speed. It was found that an addition of 5 km/h achieved this. This addition can be justified in real-world terms as car manufacturers would provide an additional measure of protection to be sure of meeting the requirements. Therefore cars will have some additional crush depth to prevent bottoming out in impact testing if the vehicle should prove slightly softer than expected. Also, some parts of the car will have more crush depth than others, so some of those hit at higher speeds will survive without injury, particularly if they are tougher than average.

Figure 10.5e shows the principle of the alternative, ‘speed-shift’ calculation. The concept is that there are pedestrian sub-system test impact speeds below which the performance limits are not normally exceeded with current car designs. Implementing the test procedures would then shift these speeds up to the equivalent car speed of the test procedure. Currently, at any given speed there will be a ratio of the numbers of casualties injured at the different severities, fatal, serious and slight, as for instance where the vertical dashed line at 35 km/h crosses the original severity distributions, which are shown dashed. It is further assumed that with implementation of the test procedure the whole severity ratio by speed distribution is shifted upwards in speed by the same amount as the shift in the performance limit speed. In the example, this shifts the ratio shown from 35 km/h to the other vertical dashed line at 50 km/h. The essence of the calculation is that the ratio of casualties by severity is shifted in speed, to reflect the improved protection provided, but the total number of casualties is not shifted, as this represents the number of casualties hit at the original speed. Therefore, in the example, the total number of casualties at 50 km/h is unchanged and is different to the number at 35 km/h. The new number of casualties of each severity at 50 km/h is thus obtained by multiplying the total by the shifted proportion of each severity. This reduces the number of fatalities and, in this case, the number of serious casualties. This shift process is repeated over the speed distribution to give the new severity distributions, shown solid. In practice the limited sample size and less regular appearance of the dataset used mean that the process has to use banded data; 10 km/h wide bands were used. In the ‘speed-shift’ calculation, accidents below the shift speed ‘drop out’ and become uninjured, as shown

here. However, in the current study no benefit is claimed for this, so effectively the total (all severities) distribution is unchanged.

10.2.7 Obtaining proportions hit by test area and at survivable speeds

Preventing some injuries to a pedestrian with multiple injuries will not necessarily benefit the pedestrian, or the benefit may be of limited value. It is assumed that impact with an improved car will not affect the likelihood of injury from areas of the car outside the area tested by the test procedures nor from later impact with the road or the exterior environment generally. Injuries currently occurring from contact with non-tested areas and the ground will therefore continue to occur. If the pedestrian should receive a fatal injury from ground contact then the result will be the same, however much improved the car is. For casualties with multiple serious injuries there will be some benefit from preventing individual injuries, but it will not be proportional to the number prevented. To maximise the benefit it would be necessary to prevent all serious injuries, so that the casualty is uninjured or only slightly injured. When a monetary value (casualty cost) is put on a seriously injured casualty, obtaining that benefit requires that the casualty is no longer defined as serious. Even then, if the casualty is still slightly injured, the benefit is offset by the residual slight casualty cost.

For seriously injured casualties it was therefore assumed that the serious casualty could be potentially 'saved' if all of the AIS 2 to 5 injuries were caused by contact with tested areas of the car. Casualties for whom there were both tested area and non-tested area / ground contact injuries in the AIS 2-5 range were counted as being potentially 20 percent 'saved', to reflect that there was some benefit in reducing the number of serious injuries.

Fatally injured casualties, in the IHRA pedestrian accident dataset, normally suffered multiple injuries. For these casualties it was not possible to determine, from the data available, which of the multiple injuries had been the fatal ones. Indeed, since all injuries reduce the well-being of the casualty, in one sense they all contribute to their death. For the purpose of the calculation, however, the assumption was made that **if** the worst injury or injuries of each fatally injured casualty was due to the contact with tested areas of the car, then that fatality would be taken as being 'saved' by the test procedures. 'Worst' injuries were taken as those where the AIS severity was the maximum for that casualty (e.g. if a casualty had injuries of AIS 4, 4, 3, 3, 3, 2, 1 & 1 then the two AIS 4 injuries would be the 'worst' injuries). For a few of these cases counted as saved, in reality, it would be necessary also to prevent one or more less serious injuries caused by the ground to save the fatality. This would result in a small overestimate of fatalities counted as saved. However, in many cases fatalities were counted as 'not saved' because they suffered two or more 'worst' injuries caused by a combination of tested area and non-tested area / ground. In some of these cases, in reality, preventing only those injuries caused by the tested area would be sufficient to save a fatality. This would result in a small underestimate of fatalities counted as 'saved'. Therefore, on balance, the method used to calculate fatalities 'saved' is considered to be reasonable.

The tested areas under the test proposals match well the descriptions of contact areas in the IHRA pedestrian accident dataset. The 'Front Bumper' and 'Front Panel' together were considered as being tested by the legform. It was assumed for the purpose of these calculations that all cars would be subject to the legform test, as the alternative upper legform test applies to relatively few vehicles with high bumpers. The 'Leading Edge of Bonnet and Wing' area was considered as being tested by the upper legform. The 'Bonnet and Wing' area was considered as being tested by the headforms. Casualties for whom there was an injury of the severity being considered, where the injury source was unknown or where non-contact injury was recorded, were not included in the analysis. All other contact areas were taken to be non-tested areas.

The method by which the hit at survivable speed and hit by tested area proportions were obtained from the IHRA pedestrian accident dataset was different for the 'uninjured up to the equivalent car speed' and the 'speed-shift' methods. For the 'uninjured up to the equivalent car speed' method the dataset was analysed on a casualty-by-casualty basis to obtain a combined proportion of those casualties hit up to the equivalent car speed and injured by tested areas. The analysis then

automatically took into account any interaction between the two effects, such as the possibility that fewer head to bonnet top impacts occurred at higher speeds because the windscreen was hit instead.

For the 'speed-shift' method, the proportions hit by tested areas were obtained on a similar casualty-by-casualty analysis, except that the proportion hit at survivable speeds was a separate part of the calculation. Any interaction between speed and the proportions hit by the tested area was allowed for by selecting a speed range of the database that roughly matched that of those considered to have been hit at survivable speeds in the speed shift part of the calculation.

The impact speed by severity distribution from the IHRA pedestrian accident dataset was used in the 'speed-shift' calculation proper. This calculation is described in more detail by Lawrence *et al.* (2002).

For the nominated relaxation zones it would not be practical to make full use of the concession over the full width allowed, because a step change in stiffness would not be possible. It was therefore assumed that the effective width of the relaxation zone would in each case be 5 percent of the car's width narrower than the allowed zone.

It was also thought that there would be some degree of correlation between the positions nominated for the three impact phases, because the bumper supports are at a similar lateral position to where the bonnet and headlight come together on the bonnet leading edge, and these are then not far away from the bonnet to wing join on the bonnet top. The database program was therefore run with and without the relaxation zones of the bumper, BLE and bonnet top lined up, and an average of these two options taken.

A way was developed for this study of analysing the IHRA database using a random number function to determine whether the casualty was strong or weak, and which zone (main or relaxed) they contacted. Multiple passes were made through the database to smooth out the effects of the random variation. If the 'strength' of the casualty thus generated was more than the injury risk for that contact then that injury was considered to be 'saved', otherwise they were considered as still being injured.

With the 'speed-shift' method in past studies a test speed was specified at which current cars are typically going to just be on the acceptance limits. Davies and Clemo (1997) selected a speed of 25 km/h for this. This speed has been used again in this study, as to select a different speed would need a considerable amount of test data at comparable test speeds. It should be noted that the method is quite sensitive to the choice of this speed.

If, for instance, the test procedures require the car to pass the same test at 40 km/h then the speed shift will be 15 km/h. However, as the manufacturer's margin is being accounted for in the current study that relationship no longer holds for the current phase two requirements. Ideally the speed at which current cars would just meet the manufacturer's target values could be determined, or a speed higher than 40 km/h could be determined, at which cars that pass with ease at 40 km/h, would only just pass. As this information was not available it was noted that the proposed phase two relaxations option would only just pass the EEVC limits at 40 km/h. The speed shift was therefore 15 km/h for this option. Some trial runs with the database program were then made to establish the speed difference at which the EEVC option would match the phase two relaxations proposal. This was found to be about 4 km/h. The speed shift was therefore taken to be 19 km/h for the EEVC or current phase two option.

The 'with BAS' option was simply taken to be at a speed shift of 2 km/h more than for the phase two relaxation proposal, i.e. at 17 km/h. However, in the equivalent car speed the estimated benefit was initially very poor, because much of the IHRA data has speeds in multiples of 5 km/h. The added benefit of BAS was therefore determined by taking the average additional benefit over a 5 km/h range of baseline speeds.

As the nominated relaxation zone (i.e. the higher criteria width or area) couldn't easily be accounted for as part of the speed shift term, this was accounted for within the tested area part of the calculation.

For the pedal cyclist strand of the calculation, there was no comparable database to use to estimate the survivable speed and tested area term or terms. In an earlier benefit study van Kampen (1994) had considered how to allow for pedal cyclists. With their greater height and speed pedal cyclists will

have a lower proportion of accidents in which they could be ‘saved’. Also, they would get less benefit when hit at their front or rear, but would be most similar to pedestrians when hit side on. He therefore considered that pedal cyclists would be saved at half the rate of pedestrians. Therefore, for this current study the rate of saved pedal cyclists will be taken to be half of the rate for pedestrians. It isn’t clear from van Kampen’s report as to when this factor was applied, whether to all pedal cyclist casualties, or only to those hit by the fronts of cars. For the current study the factor has been applied to those hit by the fronts of cars, which gives the lower estimates.

By combining the proportions hit by the fronts of cars, given in Table 10.3 with the proportions obtained from the survivable speed and tested area term or terms, the proportion of all casualties that could be saved can be calculated for each proposal, severity, road user type and method.

However, as noted earlier, it isn’t reasonable to assume that most fatalities could be converted to slight injuries or none. It is more likely that they would still be seriously injured. Therefore, an adjustment was made, reducing the numbers of seriously injured casualties saved to reflect the fatalities who are saved, to estimate the proportional reduction in serious casualties. (The proportion of fatalities saved is unchanged). See Table 10.5.

Table 10.5. Estimated proportional reductions in numbers of pedestrian and pedal cyclist casualties, by severity and estimation method, that would be obtained by implementation of the various options

Estimation method	Road user type	EEVC		Proposal		Proposal + BAS	
		Fatal	Serious	Fatal	Serious	Fatal	Serious
Uninjured up to the equivalent car speed	Pedestrians	0.115	0.208	0.096	0.175	0.104	0.183
	Pedal Cyclists	0.042	0.084	0.035	0.071	0.038	0.074
Speed-shift	Pedestrians	0.226	0.175	0.169	0.133	0.178	0.146
	Pedal Cyclists	0.083	0.070	0.062	0.053	0.065	0.058

10.2.8 Numbers of casualties ‘saved’

The proportions in Table 10.5 can now be multiplied by the numbers of current casualties estimated for the European Union, see Table 10.2 (bottom row), to predict the reduction in the numbers of casualties that could be obtained with each of the options, see Table 10.6. These are the annual savings that might be expected if cars complying with the option below formed 100 percent of the car fleet. Alternatively, if a steady state is assumed, it is the savings that would accrue over the lifetime of one year’s new car registrations.

10.2.9 Financial benefits of casualties ‘saved’

Casualty costs were obtained for Great Britain (Department for Transport, 2003) at June 2002 prices. These were used because GB casualty costs are obtained using the ‘willingness to pay’ methodology that was recommended by the COST action 313 working group (Alfaro *et al*, 1994). Many other countries do not use the recommended method, or may only use it only for fatalities. These GB casualty costs were converted to casualty costs in Euro, using the EU’s May 2004 exchange rate £0.6713 = €1 (£1 = €1.4896). These casualty costs and, for information, their breakdown into their component parts is shown in Table 10.7.

Table 10.6. Estimated annual reduction in numbers of pedestrian and pedal cyclist casualties in the European Union (EU-25), by severity and estimation method, that would be obtained by implementation of the various options

Estimation method	Road user type	EEVC		Proposal		Proposal + BAS	
		Fatal	Serious	Fatal	Serious	Fatal	Serious
Uninjured up to the equivalent car speed	Pedestrians	1,039	36,743	866	30,802	938	32,359
	Pedal Cyclists	144	9,699	120	8,130	130	8,544
	Pedestrians + P/Cs	1,183	46,442	986	38,932	1,068	40,903
Speed-shift	Pedestrians	2,039	30,783	1,521	23,544	1,608	25,743
	Pedal Cyclists	282	8,019	211	6,134	223	6,706
	Pedestrians + P/Cs	2,321	38,803	1,732	29,678	1,831	32,449
Average	Pedestrians + P/Cs	1,752	42,622	1,359	34,305	1,449	36,676

Table 10.7. Average value of prevention per casualty by severity and element of cost
Values for Great Britain (Department for Transport, 2003) converted to Euro

Injury Severity	Lost output	Medical and ambulance	Human costs	Total
Fatal	€40,057	€1,102	€1,220,751	€1,861,895
Serious	€4,639	€4,941	€69,626	€79,206
Slight	€2,607	€1,102	€2,424	€6,133

Note that because some elements of accident values are not quantified, total accident values may be regarded as minimum estimates of the cost to society.

The above costs are for reported casualties. Unreported casualties tend to have less severe injuries. Using the above costs directly would therefore over estimate the financial benefit. Hopkin and Simpson (1995) describe in detail how the casualty costs are calculated. Human costs were obtained using willingness to pay methodology for a range of different severities within the serious and slight classifications. The other components of the casualty cost (see Table 10.7) are also obtained for a range of severity. For the current study, lower and therefore more appropriate casualty costs for the unreported casualties, were obtained by taking the costs for the least severe category within both the serious and slight classifications. The total 'unreported' casualty costs were then adjusted to reflect changes in the published casualty costs since the Hopkin and Simpson report. Finally, working casualty costs were estimated that reflected the balance of reported and un-reported casualties in the calculation.

The benefits under the fatalities columns assume that fatalities 'saved' will still be seriously injured, and were estimated using the net casualty cost of fatality minus serious casualty. Similarly, the benefits under the serious columns assume that serious casualties 'saved' will still be slightly injured, and were estimated using the net casualty cost of serious casualty minus slight casualty. The estimated financial benefits for both proposals, for the various subsets and methods, are shown in Table 10.8.

Table 10.8. Estimated annual financial benefit to pedestrians and pedal cyclists in the European Union (EU-25), by severity and estimation method, that would be obtained by implementation of the various options

Estimation method	Road user type	EEVC		Proposal		Proposal + BAS	
		Fatal (€million)	Serious (€million)	Fatal (€million)	Serious (€million)	Fatal (€million)	Serious (€million)
Uninjured up to the equivalent car speed	Pedestrians	1,814	3,881	1,513	3,253	1,638	3,421
	Pedal Cyclists	251	1,011	209	848	227	891
	Pedestrians + P/Cs	2,065	4,893	1,722	4,101	1,865	4,312
Speed-shift	Pedestrians	3,561	3,372	2,657	2,575	2,809	2,810
	Pedal Cyclists	493	853	368	652	389	712
	Pedestrians + P/Cs	4,054	4,225	3,025	3,227	3,198	3,522
Average	Pedestrians + P/Cs	3,060	4,559	2,374	3,664	2,531	3,917

Table 10.9 also shows cost to benefit ratios for each vehicle fleet option. These are estimated using the benefits from the preferred option in Table 10.10, the phase two relaxations proposal with brake assist systems. Conversely, the cost to benefit ratios in Table 10.10 are estimated using the preferred costs in Table 10.9.

10.2.10 Costs of protecting vulnerable road users

In Table 9.2 the costs of various options for providing protection for vulnerable road users was shown. These costs are production costs; i.e. they are the costs to the motor manufacturers.

Most of the benefits of safer cars are obtained by members of the public, as a reduced human cost element. Much of the benefit of a reduction in lost output will also be obtained by the public. When comparing with the costs of achieving this improved safety, therefore, the best comparison is obtained by looking at the cost to members of the public. The manufacturer would typically take a 5 to 10 percent profit. The dealer's margin (including their profit) would be about 10 percent. VAT would typically be about 15 percent. Taking the middle of the range for profit gives a combined mark-up of 36 percent. This was then rounded up to 40 percent to cover a possible increase in delivery charges. The consumer costs in Table 10.9 were thereby obtained by marking up the costs in Table 9.2 by 40 percent.

Table 10.9. Consumer costs and cost to benefit ratios for the different combinations of solutions for car types

Spoiler option	Pop-up bonnet option	Consumer cost (€million)	Cost to benefit ratio
Bolt-on spoilers fitted to all of the off-roader segment and the costs attributed to pedestrian protection	No pop-up bonnets	924	1 : 7.0
	Pop-up bonnets fitted to all sports cars	1,022	1 : 6.3
	Pop-up bonnets fitted to all sports cars and executive cars	1,113	1 : 5.8
	Pop-up bonnets fitted to all sports, executive and large family cars	1,449	1 : 4.4
	Pop-up bonnets fitted to all sports, executive, large family and small family cars	1,988	1 : 3.2
No costs for fitting a spoiler to the off-roader segment attributed to pedestrian protection	No pop-up bonnets	868	1 : 7.4
	Pop-up bonnets fitted to all sports cars	973	1 : 6.6
	Pop-up bonnets fitted to all sports cars and executive cars	1,064	1 : 6.1
	Pop-up bonnets fitted to all sports, executive and large family cars	1,400	1 : 4.6
	Pop-up bonnets fitted to all sports, executive, large family and small family cars	1,939	1 : 3.3

Notes: The cost in the shaded row is thought likely to be the most appropriate for the fleet, despite it almost certainly not representing the real distribution of solutions. The cost to benefit ratio is calculated using the sum of fatal and serious costs for the Proposal + BAS option and taking the average of the estimation methods.

Table 10.10. Estimated benefit to vulnerable road users, cost to benefit ratios and lifetime benefit per car sold from implementation of the various proposals, obtained by averaging the two estimation methods

	EEVC	Proposal	Proposal + BAS
Benefit (€million)	7,618	6,037	6,448
Cost to benefit ratio	n/a	1 : 5.4	1 : 5.8
Lifetime benefit per car (€)	517	410	437

Note: The proposal with brake assist system option in the shaded column is the preferred option. The cost to benefit ratios are calculated using the consumer cost in the shaded row in Table 10.9 above.

10.3 Discussion of cost benefit study

It should be noted that the benefits in casualties saved shown in Table 10.5 are proportions of all pedestrians and pedal cyclists injured by all vehicle types. They are expressed in this way because the numbers of all pedestrian and pedal cyclist casualties are more easily available from national and international statistics, and can then be factored with the proportions given here to obtain estimates of casualty numbers that could be saved. However, for some purposes it may be more appropriate to

have estimates of the benefits as proportions of the casualties currently injured by cars or by the fronts of cars that will be made safer. These can be obtained by effectively removing the proportion injured by cars or by the front of cars factor from the chain calculation. These proportions injured by cars and by car fronts were given in Table 10.3. Hence, the proportional reductions in those casualties hit by cars and by the fronts of cars, that would be obtained by implementation of the various options, were estimated and are shown in Table 10.11.

Table 10.11. Estimated proportional reductions in numbers of those pedestrian and pedal cyclist casualties hit by cars and by car fronts, that would be obtained by implementation of the various options, by severity and estimation method

Sample	Estimation method	Road user type	EEVC		Proposal		Proposal + BAS	
			Fatal	Serious	Fatal	Serious	Fatal	Serious
Those hit by cars	Uninjured up to the equivalent car speed	Pedestrians	0.163	0.250	0.136	0.209	0.147	0.220
		Pedal cyclists	0.077	0.104	0.064	0.087	0.070	0.092
	Speed-shift	Pedestrians	0.319	0.209	0.238	0.160	0.252	0.175
		Pedal cyclists	0.151	0.086	0.113	0.066	0.119	0.072
Those hit by car fronts	Uninjured up to the equivalent car speed	Pedestrians	0.191	0.373	0.159	0.313	0.173	0.328
		Pedal cyclists	0.096	0.189	0.080	0.158	0.086	0.166
	Speed-shift	Pedestrians	0.375	0.312	0.280	0.239	0.296	0.261
		Pedal cyclists	0.188	0.156	0.140	0.119	0.148	0.131

The estimates obtained by the ‘uninjured up to the equivalent car speed’ and the ‘speed-shift’ methods differ markedly in their relative benefits for the two severities (see Tables 10.5, 10.6 and 10.8), demonstrating that estimates of this type are not precise. The ‘speed-shift’ method is thought to over-estimate the potential for saving lives at higher car speeds, as cars are likely to be optimised to pass at the test speed, with limited crush depth in-hand to provide protection at significantly higher speeds. Safe cars are likely to be more consistent in stiffness, as stiff areas are made safer. This will cause the impact speed distribution of serious casualties to become narrower, potentially increasing the proportions of casualties saved above the predictions of the ‘speed-shift’ method. On the other hand, the ‘uninjured up to the equivalent car speed’ method is likely to under-estimate the potential for saving lives at higher car speeds, as the test procedure could be expected to be effective in saving fatalities at speeds higher than those up to which serious casualties are saved. Once benefits from saving fatalities and seriously injured casualties have been added together, the differences between the two estimation methods are much smaller, and therefore the average of the two estimates is used to calculate the values in Tables 10.9 and 10.10.

The cost to benefit ratios are given in Tables 10.9 and 10.10. It can be seen that these estimates are very favourable to the protection of vulnerable road users. However, it should be noted that these estimates have considerable uncertainty attached to them. The estimates of injuries saved are sensitive to some of the assumptions made about how well cars that are designed to meet the test procedures will protect vulnerable road users from injury. On the cost side, also, there are uncertainties about how much the protection required will cost. Indeed, there can be no exact cost for protecting vulnerable road users, as it depends on how the manufacturer makes engineering compromises between the various demands on the car design.

There are a number of factors that could lead to either under or over estimating the cost to benefit ratio. The ones thought to result in an over estimate of benefits or under-estimate of costs are given below:

- Casualty costs reflect the wealth of those that they are obtained for. With greater wealth people are prepared to spend more to avoid injury or death, and values for lost output will also be greater. The casualty costs used were for Great Britain. These are up-rated annually according to the increase in GDP per capita. These will be approximately correct when extended to the EU-15, but with the recent expansion to the EU-25 the values used will be higher than a wealth-adjusted casualty cost would be. Moreover, with higher casualty rates per 100,000 population in the new member states, the adjusted casualty costs would be lower still if weighted by casualties rather than by population.
- The costs obtained from Table 9.2 relate to production costs only, although in this section they have been converted to consumer costs for the cost benefit study. Menard Engineering Limited mentioned fuel economy and insurance issues, but no costs were provided for these aspects. It is debatable as to what these aspects might add to costs. In the Davies and Clemo (1997) study these costs were considerable. However, the Honda Civic provides significant pedestrian protection without any obvious detriment to either fuel economy or insurance rating (Lawrence *et al.*, 2002).
- The consumer costs would arise when a car is purchased, but the benefits may arise several years later. With a 10-year life of a car being fairly typical, the benefits would be obtained on average about 5 years later. These future benefits could be discounted back to the time of purchase, which would reduce their value at that time.
- No account has been taken of the known long-term downward trend in pedestrian casualties. This has been occurring in the EU-15 countries as a whole over at least the last three decades. It is likely that pedal cyclist casualties are behaving similarly. However, information isn't to hand as to what the trend is in the EU-25; it may be with the high accident rate in the new member states that the current trend is upward. However, even if this is the case it is likely that in time the new members will conform more to the accident pattern of the older members.
- There is also a long-term upward trend in the number of cars sold, which would add to costs proportionally. On the other hand, increasing wealth (in excess of inflation) increases casualty costs and hence the benefits from saving casualties.
- Inevitably, simplifications had to be made in the calculation. No account was taken of the proposed reductions in upper legform to bonnet leading edge test energy. Benefits from preventing head injuries will be over-stated as the injury risk curve used is for AIS 4+ injuries rather than AIS 2+.
- It was effectively assumed in the calculation that injuries in the IHRA database occurred at random across the width of the bumper and bonnet leading edge, and over the surface of the bonnet top. In practice the areas that are likely to be in the nominated relaxation zones are some of the areas that are particularly injurious on current 'unsafe' cars. Therefore, these areas will be over represented within the injuries in the IHRA database (although the database doesn't record impact location that precisely). It follows that the calculation will have assumed too high a proportion of injuries were in the higher safety zone and over estimated the injuries 'saved'.

Given how favourable the cost to benefit ratios are, it is very unlikely that the above factors could have made a significant difference in demonstrating that the proposed phase two protection requirements are justified financially.

As was expected, it can also be seen in Table 10.10 that the financial benefits that might be obtained from implementing the current phase two option of full EEVC WG17 are greater than the other two options, of implementing the proposal contained in Section 7.4.1, with or without brake assist systems. However, as was discussed in Section 7, this option is not considered to be feasible and no costs have been obtained for it. (Costs for EEVC WG17 compliance from previous TRL studies

should not be used, as they are not comparable with the costs obtained in this study.) It can be calculated from Table 10.10 that the benefits of the proposed package of relaxations are estimated to be 79 percent of the benefits of the current phase two requirements. With the additional of brake assist systems this effectiveness proportion rises to 85 percent.

The cost of fitting brake assist is thought to be low as much of the hardware will already be present as part of the ABS system. As brake assist systems will have considerable benefits in other kinds of accidents, it is not unreasonable to attribute little of this extra cost to pedestrian protection. Therefore, in the cost benefit ratio calculation the cost of brake assist systems has been taken as zero.

Although these comparisons of benefit would not be affected by the factors listed above, there are still significant uncertainties contained within the method, which would affect these effectiveness percentages. In particular, the benefits of brake assist systems must be regarded as indicative only, as insufficient data have as yet been supplied by ACEA to accurately gauge their benefits for vulnerable road users.

Nevertheless, brake assist systems are capable of compensating for much of the benefit lost by the package of relaxations that was proposed on feasibility grounds. The recommendation is therefore strongly made that brake assist systems should be mandated as part of the package of relaxations.

There are a number of additional benefits from brake assist systems that have not been quantified here. By reducing vehicle speeds the driver will have more time to take avoiding action. Similarly, the pedestrian will have more time to finish passing in front of the vehicle or to actively take avoiding action. Also, the benefits of brake assist will apply to all parts of the car, not just the tested area. More than this, the pedestrian's speed after the vehicle impact will also be reduced by BAS, so ground injuries will be reduced.

It should also be noted that the relative benefit of BAS compared with the reduction in pedestrian protection from the proposed phase two relaxations is sensitive to the assumptions made as to the proportions of injuries saved. If savings for both the current and proposed phase two have been inadvertently overstated then BAS will be able to offset more of the reduction in pedestrian protection that has been proposed here by TRL on feasibility grounds. The standard of protection provided by phase one is significantly lower than that provided by the proposed phase two relaxations, so it is considered that even with the addition of BAS to phase one requirements it would be difficult to achieve the level of savings provided by the current phase two requirements.

The benefits in Euro estimated for the European Union have increased by 134 percent (i.e. a factor of 2.34 times) since the previous TRL study (Lawrence *et al.*, 2002). It is instructive to identify the reasons, using the EEVC option as this is the only comparable option between the two studies. Changing from the EU-15 to the EU-25 has added 59 percent to the benefit, because of the high accident rate in many of the newly joined countries. Including pedal cyclist casualties has added 21 percent and allowing for under-reporting rates 16 percent. A modest 9 percent increase in casualty costs in UK pounds has been offset by an -8 percent change in benefits due to the movement of the exchange rate. These factors together would account for 124 percent of the increase, if it is assumed that they act independently.

11 Summary of possibilities and recommendations

There are a number of issues that should be considered before phase two of the Directive is introduced. These include:

- possible improvements to the test methods and their protection criteria
- are the costs of providing the protection justified by the potential savings in seriously and fatally injured casualties?
- is it feasible to provide the level of protection required in phase two within a functioning vehicle?
- if not, what should the test requirements be to obtain the optimum balance between feasibility and the protection of vulnerable road users?
- will the requirements be unreasonably restrictive to certain vehicle types or scales of production?

Most of these issues have been studied in depth in the preceding sections of this report and are briefly summarised below:

A number of improvements to the test methods have been identified, the most significant of which are a heavier child headform impactor, revised upper legform test energies and new or reduced tolerances on test conditions. These changes will mean that the protection required will be more appropriate and it is thought that all the changes will make it easier for car manufacturers to achieve compliance.

It has been concluded that, although meeting phase two of the Directive might be feasible for some types of vehicles, overall it would be unduly restrictive and is therefore not feasible without some modifications. Therefore a number of changes to phase two of the Directive have been proposed and it is thought that with these changes phase two would be feasible and reasonable. These changes are based on data and observations on feasibility issues provided to TRL by:

- the European car industry in a series of face-to-face meetings and in documents provided to TRL following these meetings.
- the associations of European and Japanese car manufacturers.
- a response was also received from the Korean association of car manufacturers, however they had no comments on phase two of the Directive.

In addition, current cars with good pedestrian protection were examined and TRL's experience gained over a number of years work in the field of pedestrian protection was also used to consider feasibility issues.

The most significant of the changes proposed for feasibility are the introduction of small zones that manufacturers are allowed to nominate as 'difficult areas' to be subjected to a less demanding test, adjustments of the protection criteria in the main area to take advantage of the manufacturers' extra safety allowance and a reduction in the severity of the upper legform test for more upright vehicles, by applying a lower energy cap.

A study of the costs and benefits of phase two of the Directive has been carried out for various options and these show that the introduction of the phase two requirements (with the proposed modifications) is well justified on financial grounds.

The aim of the following sections is to summarise these findings in a form in which they could be used to adjust the phase two test methods and criteria, and to justify the implementation of phase two with the revisions suggested.

11.1 Legform test

Some changes to the phase two requirements have been proposed for this test method, in Section 7.4.1, both to improve the test method and take account of feasibility issues, these are restated below:

- Add a shoe thickness allowance so that the foot end of the impactor is required to be 25 mm from the ground at first contact;
- halve the legform height and verticality (in the longitudinal plane) tolerances at first point of contact to ± 5 mm and $\pm 1^\circ$;
- increase the knee bending angle performance criterion from 15° to 19° ;
- increase the tibia acceleration protection requirement for the bumper from 150 g to 190 g;
- allow manufacturers to nominate bumper test widths of up to 264 mm in total, for testing with a tibia acceleration protection requirement of 250 g.
- add new requirement for the relative humidity to be controlled to $35 \pm 15\%$ in the vehicle test and to $35 \pm 10\%$ in the legform dynamic certification test;

In addition it is recommended that consideration should be given to carrying out further research on the effects of humidity on the performance of the ConforTM foam flesh in the legform dynamic certification test; the results of which could be used to confirm or adjust the humidity and pass / fail tolerances.

It is strongly recommended that a tolerance be introduced on the accuracy with which impact speed is measured. It is recommended that consideration be given to introducing the Euro NCAP tolerance of ± 0.02 m/s in phase two of the EC Directive.

It is recommended that a code of practice be established that provides requirements for appropriate methods of preventing misuse of movable or removable spoilers on off-road vehicles, as outlined in Section 7.4.1.1.

With these changes the difficulty of meeting the phase two Directive requirements is thought to be very similar to that of the current phase one. This is because the criteria are only slightly lower than those of phase one (phase one bending criterion is 21° and acceleration criterion 200 g) and the addition of a 25 mm shoe allowance should help to reduce knee bending in most cases.

It might appear reasonable to assume that phase one of the EC Directive is feasible for all the vehicle types that it applies to, as the car manufacturers associations offered to provide this level of protection voluntarily. Although this assumption is thought to be appropriate in most cases it might prove more difficult to provide leg protection for some vehicle types. This may be the case for some streamlined vehicles with a low ramp angle. For these vehicles it will be difficult to provide the protection by extending the length, as this will have an adverse effect on ramp angle and cooling. Many vehicles already have some crush depth available so that it is thought that typically only about 20 mm of additional length is required but for those that currently have none, an additional depth of approximately 60 mm must be provided. Therefore, for vehicles where it is difficult to increase the length and where all the available length is needed for mechanical parts or as crush for occupant protection, there may be a case to allow some further relaxation. However, as phasing in of the requirements is already included in the Directive's implementation dates, it is unlikely that it will be necessary to adapt an existing design and so it should be possible to build in crush depth for both occupant and pedestrian protection when designing new vehicles.

The most significant changes are to improve the test method and these, along with comparatively minor changes for feasibility are thought to make the revised phase two legform requirements feasible. Therefore it is thought that they provide the correct balance between feasibility and protection of vulnerable road users. Nevertheless, if thought necessary, one option would be to introduce some additional relaxation of the protection requirements, but only for 'difficult vehicles'.

However, vehicles with especially difficult bumper area may be difficult to define, within a regulation. If this option is needed then it is recommended that the acceleration criterion be increased by a larger margin than the knee bending criterion in order to ensure that the risk of saving tibia fractures at the expense of knee joint injuries is avoided. This is because a tibia fracture is less likely to result in long term disability than a knee joint injury.

11.2 High bumper test

Again, some changes to the phase two requirements have been proposed for this test method, in Section 7.4.1, both to improve the test method and take account of feasibility issues, these are restated below:

- Test high bumpers only with the upper legform impactor, i.e. withdraw the option for manufacturers to choose between testing with the legform or the upper legform impactor;
- revise the definition of the 'Upper Bumper Reference Line' so that the centreline of the upper legform impactor is aligned with the centre of the bumper structure. The revised wording proposed in Section 3.3.2 can be used for this or any alternative thought better by WG17;
- where permanent towing eyes are positioned beneath a high bumper, in such a position that they are not contacted by the upper legform impactor in the test, then they must be set back at least 120 mm behind the front face of the bumper;
- add new requirement for the relative humidity to be controlled to $35 \pm 15\%$ in the vehicle test and to $35 \pm 10\%$ in the upper legform dynamic certification test;
- increase the force and bending protection requirement for the high bumper from 5 kN to 6.25 kN and from 300 Nm to 375 Nm;
- allow manufacturers to nominate bumper test widths of up to 264 mm in total for testing with force and bending moment protection requirements of 7.5 kN and 510 Nm respectively.

In addition it is recommended that consideration should be given to applying to the upper legform to high bumper test any changes to the humidity tolerances that may be recommended from further research on the effects of humidity on the performance of the Confor™ foam flesh in the legform dynamic certification test.

It is strongly recommended that a tolerance be introduced on the accuracy with which impact speed is measured. It is recommended that consideration be given to introducing the Euro NCAP tolerance of ± 0.02 m/s in phase two of the EC Directive.

With the above changes the difficulty of meeting the phase two Directive requirements is reduced although it is still more demanding than the current phase one where the criteria are 7.5 kN for the sum of force and 510 Nm for the bending moment. Although it may not always be easy to provide the necessary crush depth in this area it is not thought to be an insurmountable problem to meet this revised phase two requirement, so it is not necessary to consider any further relaxation.

There is a misconception that the switch to a high bumper test should be set at such a level that it includes all off-road vehicles, however, the definition is set based on which impactor is most appropriate. As this should not be set by the intended use of the vehicle it is recommended that requests to change the definition of a high bumper for this reason should not be accepted.

Overall it is thought that the changes for feasibility in the high bumper test provide the correct balance between feasibility and protection of vulnerable road users.

11.3 Upper legform test

Once again, some changes to the phase two requirements have been proposed for this test method, in Section 7.4.1, both to improve the test method and take account of feasibility issues, these are restated below:

- Change the angle of the straight edge used to determine the bonnet leading edge reference line from 50 degrees to the vertical to 40 degrees;
- replace the current upper legform test energy graph and interpolation rules with the revised one proposed in Section 3.3.3.3;
- review the current test velocity curves in conjunction with the new energy curves and adjust the velocity curves as necessary so they do not require an impactor mass below 9.5 kg;
- reduce the energy cap from 700 J to 500 J;
- increase the force and bending protection requirement for the bonnet leading edge test from 5 kN to 6.25 kN and from 300 Nm to 375 Nm;
- allow manufacturers to nominate bonnet leading edge test widths of up to 300 mm in total, for testing with force and bending moment protection requirements of 7.5 kN and 510 Nm respectively.
- add new requirement for the relative humidity to be controlled to $35 \pm 15\%$ in the vehicle test and to $35 \pm 10\%$ in the upper legform dynamic certification test;

It is recommended that consideration should be given to applying to the upper legform to bonnet leading edge test any changes to the humidity tolerances that may be recommended by further research on the effects of humidity on the performance of the Confor™ foam flesh in the legform dynamic certification test.

It is strongly recommended that a tolerance be introduced on the accuracy with which impact speed is measured. It is recommended that consideration be given to introducing the Euro NCAP tolerance of ± 0.02 m/s in phase two of the EC Directive.

With the above changes the difficulty of meeting the phase two Directive requirements is reduced significantly and it is now thought to be feasible. Overall it is thought that the changes for feasibility for the upper legform test method provide the correct balance between feasibility and protection of vulnerable road users.

It may be suggested that, because the femur and pelvis injuries are infrequent with current cars, this test is not needed. However, without the upper legform test, changes to the bumper to meet the legform test could save injuries to the knee and leg below the knee at the expense of increasing femur and pelvis injury. Children will also be hit by the bonnet leading edge; the body part hit will depend on the car size and the child's stature. So for children the compliance provided to meet the adult upper legform test will also be effective in protecting the child femur and pelvis and be effective to some degree in protecting the abdomen, thorax, neck and head. Therefore, it is recommended that any proposals to remove the upper legform test or to retain the monitoring requirement of phase one should be rejected.

The changes made for this area are new energy curves that require a lower test energy, a reduced energy cap, reduced protection requirements in the main test area (increased performance criteria) and the provision of a relaxation zone with a further reduction in protection requirement. Taken together these changes represent a considerable reduction in the difficulty of meeting this test. Changes made to improve the bumper contact are very likely to increase the severity of the bonnet leading edge contact so without sufficient protection here the number of femur and pelvis injuries could increase. Therefore it is recommended that any suggestion, that the test severity should be reduced further, should be rejected.

11.4 Child and adult headform test

Changes to the phase two requirements have also been proposed, in Section 7.4.1, for this test method both to improve the test method and take account of feasibility issues, these are restated below:

- Replace the 2.5 kg child headform impactor with the current 3.5 kg headform impactor, as used in phase one for testing the child test area (between the 1000 mm and 1500 mm Wrap Around Distance and the side Reference Lines). Retain the phase two test velocity of 40 km/h;
- replace the 2.5 kg child headform certification method with the current 3.5 kg headform dynamic certification method and limits as used in EC Directive phase one;
- replace all references to spacing for child test point selection based on the radius and diameter of the 2.5 kg headform (65 mm and 130 mm) with those of the for the 3.5 kg headform (82.5 mm and 165 mm);
- replace the 4.8 kg adult headform impactor with a 4.5 kg headform impactor for testing the adult test area [between the 1500 mm Wrap Around Distance and the Bonnet Rear Reference Line (or 2100 mm for vehicles with long bonnets) and the side Reference Lines]. Retain the phase two test velocity of 40 km/h;
- replace the 4.8 kg adult headform specification with a revised one for a similar impactor design and flesh but with a reduced mass of 4.5 kg;
- replace the 4.8 kg adult headform certification pass / fail limits with ones appropriate for the chosen 4.5 kg headform tested to the current procedure. Alternatively adopt the Japanese or ISO adult head certification method and limits;
- increase the HIC protection requirement for the bonnet top (child and adult test areas) from HIC 1000 to HIC 1250;
- allow manufacturers to nominate up to 25 percent of the child and up to 25 percent the adult bonnet top test areas, for testing with head protection requirements of HIC 2000;
- For vehicles of such a size that all parts of the bonnet rear reference line are at a wrap round distance of 1700 mm or less, any adult test area will be defined as a 'small adult area'. Small adult areas can be tested, point by point, with either the child headform or the adult headform, based on the manufacturer's nominated child and adult areas within the specified small adult area. For a small adult area, up to 25 percent of the area can be nominated for the HIC 2000 test, with this 25 percent of the area apportioned to the child or adult headform test in the same ratio as for the whole of the small adult area.

In addition it is strongly recommended that the views of WG17 are obtained in producing the revised 4.5 kg adult headform specification and certification limits.

It is strongly recommended that a tolerance be introduced on the accuracy with which impact speed is measured. It is recommended that consideration be given to introducing the Euro NCAP tolerance of ± 0.02 m/s in phase two of the EC Directive.

With the above changes the difficulty of meeting the phase two Directive requirements is reduced significantly and it is now thought to be feasible. Once again it is thought that overall the changes for feasibility provide the correct balance between feasibility and protection of vulnerable road users.

Accident data show a need for both child and adult test zones and this is required in phase two of the Directive. Furthermore, accident data show that there is an area where the impact of both child and adult heads overlap. Therefore, the abrupt change between child and adult test areas in phase two of the Directive is intentional, because in practice this will result in a zone that is safe for the heads of both children and adults. The use of just one headform mass to test the whole bonnet top area in phase one was based on the difficulty of meeting the HIC 1000 requirement with two very different headform masses. However, if the above recommendation to change the mass of the child and adult

impactors is accepted, then the ratio of adult to child headform mass will have been reduced from 1.9 to 1.3. Not only will this reduce the feasibility issues for the child to adult transition but it will also reduce the concern about the low bonnet stiffness needed to meet the protection criterion with a 2.5 kg headform. Therefore, as accident data show that two headforms are necessary and feasibility issues are significantly reduced it is recommended that any proposals to use one headform mass for the whole bonnet top area be rejected.

Proposals may also be made to reduce the headform test velocity from the 40 km/h currently required in phase two of the Directive. However, it should be noted that a small reduction in test speed will result in a far larger reduction in protection than might be imagined. The likely reduction in number of casualties that could be saved, caused by reducing the test speed, can be gauged by examining the casualty distribution by velocity shown in Figure 11.1 for a reduction in speed from 40 to 35 km/h. Although this distribution is for injuries to all body regions the head is one of the two most frequently injured body areas so it is thought that this distribution will give a good indication of the effect of reducing the head test speed. The figure shows that a reduction of only 5 km/h will reduce the number of fatality injured casualties that could potentially be saved by about 50 percent and the number of seriously injured casualties by about 20 percent.

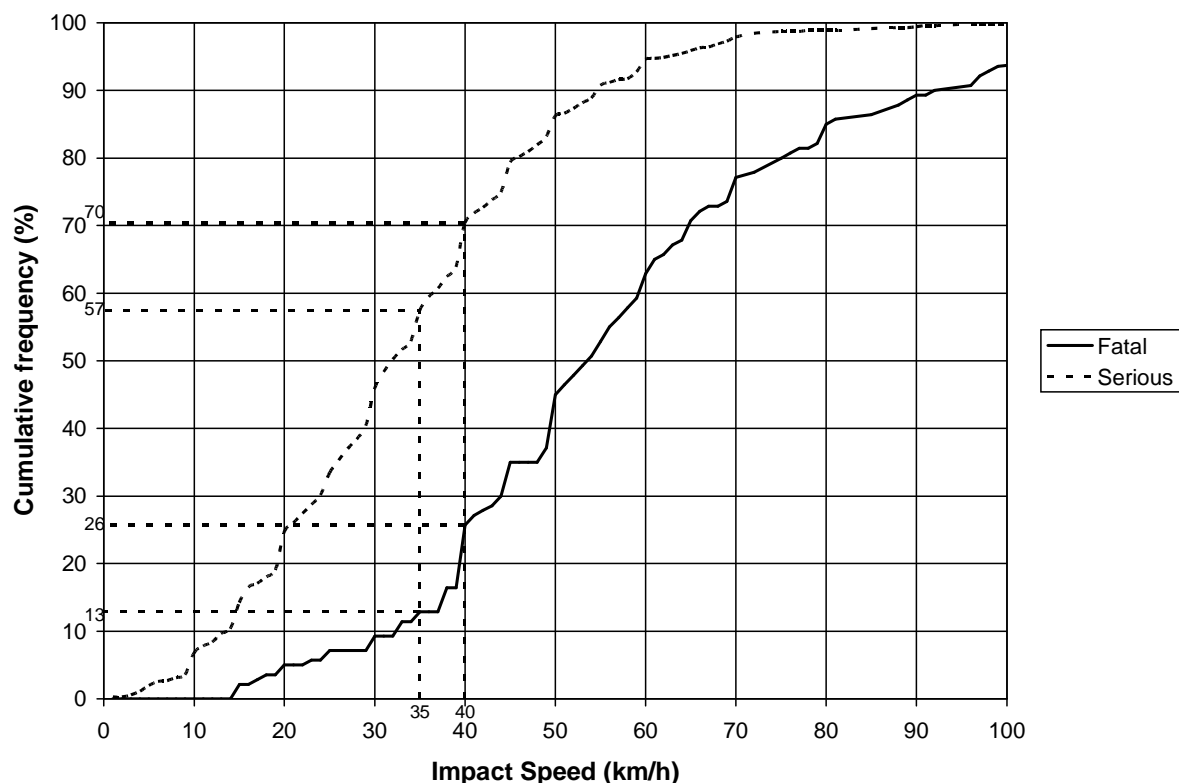

Figure 11.1 Cumulative impact speed distribution from the IHRA pedestrian accident dataset, for serious and fatally injured casualties

In some pedestrian accidents the kinematics will be such that the shoulder will hit before the head and this contact will reduce the head velocity. However, it is thought likely that in most accidents the shoulder will not protect the head in this manner, because of variations in the direction of pedestrian and vehicle motion. This, combined with the high likelihood of the bumper impacting one leg before the other, which will introduce some rotation of the torso before head contact, means that the shoulder will rarely make a significant impact with the bonnet. When the shoulder is perpendicular to the bonnet when it hits, it is still unlikely to protect the head because the shoulder in real life is relatively unstable and is likely to collapse and make little difference to the head impact velocity. However, as

discussed in Section 3.2.3, the IHRA computer simulation model has a completely rigid shoulder and this type of unrealistic shoulder representation is frequently used when simulating car to pedestrian impacts. Therefore, the use of such data to suggest that the head impact velocity will be lower than the car impact velocity should be viewed with caution and it is recommended that it should not be used to justify a reduction in test speed.

The limited feasibility data for difficult areas suggests that the provision of the proposed HIC 2000 relaxation zone should be sufficient to make it feasible to make these areas comply at a speed of 40 km/h. The introduction of the less demanding HIC 1250 criterion for the remaining area of the bonnet top test area is thought to make this area also feasible. Nevertheless, if it is thought necessary to introduce some further relaxation on the grounds of feasibility, then it is recommended that this be for a small area and that the speed is only reduced by a small margin. This is because the number of casualties that are 'saved' is very sensitive to changes in test speed. In hand with this, reducing the test speed by only a small amount will reduce the difficulty of meeting the test significantly because the test energy and therefore the difficulty is reduced by the square of the velocity.

11.5 Cost benefit

Estimated annual costs for producing cars with pedestrian protection have been estimated for the countries of the European Union in Section 9.3. These costs are provided for different permutations of solutions in Table 9.2. Whilst none of the following combinations is expected to match the real fleet distribution of solutions, it is thought that the real cost is likely to lie within the range of figures in Table 9.2. Of these, it is thought that the cost for having bolt-on spoilers fitted to all of the off-roader segment and pop-up bonnets fitted to all sports cars and executive cars is likely to be the most appropriate for the fleet, despite it almost certainly not representing the real distribution of solutions.

Estimates of the cost benefits are provided in Section 10.2.10 in Table 10.9 and it can be seen that the consumer cost to benefit ratio for this combination is favourable at 1 : 5.8 for the proposed revised phase two requirement. Therefore it can be concluded that overall the introduction of the proposed revised version of phase two of the Directive can be well justified on cost benefit grounds.

Although the most expensive combination of pedestrian protection solutions are unlikely to represent the vehicle fleet they are thought to be a reasonable estimate of the highest cost that might result from requiring protection to the proposed revised phase two requirements. It can be seen from Table 10.9 that the consumer cost to benefit ratio for the most expensive combination of protection measures is also favourable at 1 : 3.2. Therefore even when the highest likely cost is compared with the benefits the introduction of the proposed revised version of phase two of the Directive can still be well justified on cost benefit grounds.

The cost to benefit ratios are given in Table 10.8 and Table 10.9 of Section 10. It can be seen that these estimates are very favourable to the protection of vulnerable road users. However, it should be noted that these estimates have considerable uncertainty attached to them. The estimates of injuries saved are sensitive to some of the assumptions made about how well cars that are designed to meet the test procedures will protect vulnerable road users from injury. On the cost side, also, there are uncertainties about how much the protection required will cost. Indeed, there can be no exact cost for protecting vulnerable road users, as it depends on how the manufacturer makes engineering compromises between the various demands on the car design. It should be noted that little consideration has been given in this study of the effects of pedestrian protection on fuel consumption; any increase will affect the running cost. The changes for feasibility should mean that it will be possible to meet current bumper damageability test requirements, and that excessive 'softness' will not be required at areas such as the bonnet leading edge, child test area of the bonnet top and the wing edge. However, the provision of pedestrian protection could increase some repair costs and hence insurance costs. It should be noted that no allowance has been made for this in these estimates of costs here. Menard Engineering Limited mentioned fuel economy and insurance issues, but no costs were provided for these aspects. It is debatable as to what these aspects might add to costs. In the Davies and Clemo (1997) study these costs were considerable. However, the Honda Civic provides

significant pedestrian protection without any obvious detriment to either fuel economy or insurance rating (Lawrence *et al.*, 2002).

There are a number of factors that could lead to either under or over-estimating the cost to benefit ratio. However, given how favourable the cost to benefit ratios are, it is very unlikely that any factors that might have caused an over estimate of benefits or under-estimate of costs could have made a significant difference in demonstrating that the proposed phase two protection requirements are justified financially.

11.6 Relaxation of protection verses benefits of brake assist

One subject for this study was of the development and availability of new technologies that could be used to provide increased protection for pedestrians and other vulnerable road users. However, to be considered as being available, they had to be developed to such a stage that it can be clearly demonstrated that they are capable of being incorporated, with a certainty of success, i.e. compliance with the requirements of phase two by 2010 and 2015. Pop-up bonnets triggered by contact sensors in the bumper appear most likely to be one such new technology that meets this criterion.

The European vehicle manufacturers association ACEA was asked to propose new technologies that would meet the above definition and they proposed brake assist. Although, strictly speaking, this does not meet the above definition of complying with phase two, it will save some pedestrian casualties by helping to optimise the use of vehicle brakes in an accident situation. When drivers have time to react before potential accidents, savings will result from some reductions in speed before impact and some cases where impact is avoided.

Some of the changes proposed for phase two of the Directive have been suggested to improve the feasibility of making cars to meet the protection requirements and although they may be well justified they will degrade to some extent the level of protection provided by the current phase two requirements. An estimate of the effect of the proposed changes for feasibility has been produced in Section 10.2.10 and it can be seen in Table 10.10 that the annual benefits of the full (current) phase two requirements would be €7,618 million. It can be calculated from Table 10.10 that the benefits of the proposed package of relaxations for feasibility are estimated to be 79 percent of the benefits of the current phase two requirements. With the additional of brake assist systems this effectiveness proportion rises to 85 percent.

The cost of fitting brake assist is thought to be low as much of the hardware will already be present as part of the ABS system. As brake assist systems will have considerable benefits in other kinds of accidents, it is not unreasonable to attribute little of this extra cost to pedestrian protection. Therefore, in the cost to benefit ratio calculation, the cost of brake assist systems has been taken as zero.

It should be noted that the estimated benefits of brake assist systems must be regarded as indicative only, as insufficient data have as yet been supplied by ACEA to accurately gauge their benefits for vulnerable road users.

Nevertheless, brake assist systems are capable of compensating for much of the benefit lost by the package of relaxations that was proposed on feasibility grounds. The recommendation is therefore strongly made that brake assist systems should be mandated as part of the package of relaxations.

11.7 Protocol for deployable (contact or pre-contact) systems

As discussed in Sections 6 and 7, it is thought vital that the deployable systems work reliably and in an appropriate way in all combinations of pedestrian accidents. 'Appropriate' here may mean not operating in all high speed accidents. As already discussed, test methods and tools to assess the performance of the pedestrian accident detection system used to trigger such a device must be appropriate for the human property or properties that the technology detects and the assumptions in the algorithms that are used to determine if contact with a pedestrian has started or is about to occur. A further assessment programme is necessary to ensure that once triggered the system deploys safely,

reliably and in time for all combinations of accident situation, or not operate if appropriate. Again, such a programme must be matched to the deployment system used.

Ideally all this could be achieved by requiring that the system be examined by following a well-defined evaluation programme.

However, because the first two stages of this process must be matched to the solution used and very different solutions and combinations of technologies could be used in deployable systems, it is not possible to have a clear-cut assessment method. Therefore, it is recommended that a generic protocol be developed and used to assess deployable systems.

Then, once a complete system has been shown to work as intended, the protection that it offers can be assessed by testing it in the deployed position using the tests described in phase two of the Directive, linking as necessary the timing of the deployment and pedestrian test impact. However, depending on the size, location and method of operation of the deployable system some additional rules may be needed in the phase two test methods to, for example, select appropriate test areas and test locations. This is because a vehicle with active system(s) will effectively have two or more shapes, and also gaps at the edges of the deployable system. Some guidance for marking the bonnet top test area for pop-up bonnets has been given in Section 7; however, there may be a need to develop further rules as new technologies are developed.

A prototype sensor legform has been developed as part of this study. This legform is intended for testing a bumper to leg contact sensor. The sensor legform is described in Section 5 and it is thought to be a good starting point for developing an impactor for a bumper contact switch / force type sensor system, however, it would need far more development before it could be used to approve such a trigger system.

Some guidance on what should be included in a general protocol has been provided in Section 7 and a more detailed protocol was proposed by Chinn and Holding (2003) in their guide to assessing active adaptive secondary safety systems.

Deployable systems appear to offer many advantages over conventional passive protection measures; however, it is thought that a flexible approach will be needed in the methods used to show:

- that they work reliably and in an appropriate way in all combinations of pedestrian accident,
- that they provide appropriate protection when deployed.

11.8 Small series production

Passenger cars built in small series can currently be granted derogations on a discretionary basis by the Member States, provided they were registered in their territory. However, a proposal for a Directive (Commission of the European Communities, 2003) includes a new procedure for verifying the conformity of a small series vehicle by means of simplified tests or by comparison with tests carried out on similar vehicles, without there being a need to undergo the entire type-approval procedure.

The proposal states “The concept of the European small-series procedure is based on a simplified administrative process, and not on a lowering of the safety or environmental aspects; the manufacturer may demonstrate, in a limited number of cases, compliance with the requirements of a regulatory instrument by himself producing evidence or test reports, subject to the agreement of the approval authority.”

In the case of pedestrian protection it may be difficult to demonstrate compliance using the methods proposed. It may also be difficult and unduly expensive, for manufacturers that only make cars in small series, to develop a vehicle that provides in full the safety standards required for pedestrian protection. Therefore, it is recommended that some consideration be given to just requiring manufacturers who exclusively produce cars in small series to demonstrate that they have paid due

care and attention to pedestrian protection, by, for example, providing sufficient crush depth and a stiffness that is approximately appropriate.

11.9 Vehicle parts not covered by phase two

The IHRA Pedestrian Safety working group have shown an interest in including the A-pillars and roof leading edge in the adult headform test zone. At the moment, there is no feasible method of reducing the resulting HIC to less than 1000; therefore it is currently unfair to require this of manufacturers through legislation. However, by the time of the commencement of phase two of the EC Directive, protection may be available. Therefore it is recommended that some consideration be given to introducing a review, at some time in the future, to consider the feasibility of adding a requirement to test these areas.

Acknowledgements

The work described in this report was carried out in the Vehicle Safety and Engineering Department of TRL Limited.

TRL gratefully acknowledges the assistance provided by one first tier supplier and a number of car manufacturers.

References

ACEA (2004a). *Personal communications, dated 24 February 2004, 19 March 2004, 20 April 2004 and 30 April 2004.* The Secretary General, European Automobile Manufacturers Association.

ACEA (2004b). *Personal communication, dated 13 May 2004.* The Secretary General, European Automobile Manufacturers Association.

Alfaro J-L, Chapuis M and Fabre F (Eds) (1994). *COST 313 - Socio-economic cost of road accidents – Final report of the action.* EUR 15464 EN. Luxembourg: Office for Official Publications of the European Communities.

Arnoux P J and Cesari D (2003). *Pedestrian injury mechanisms of the lower limb a finite element approach.* Presentation to the 14th meeting of the International Harmonised Research Activities (IHRA) pedestrian safety working group.

Bhalla K, Bose D, Madeley J, Kerrigan J, Crandall J, Longhitano D and Takahashi Y (2003). *Evaluation of the response of mechanical pedestrian knee joint impactors in bending and shear loading.* Proceedings of the 18th international technical conference on the Enhanced Safety of Vehicles, Nagoya Japan, 19-22 May 2003. Washington DC: Department of Transportation, National Highway Traffic Safety Administration, NHTSA (available on NHTSA website - www.nhtsa.dot.gov).

Bosma F, Gaalman H A E and Souren W H M (2001). *Closure and trim design for pedestrian impact.* Proceedings of the 17th international technical conference on the Enhanced Safety of Vehicles, Amsterdam, The Netherlands, 4-7 June 2001. Washington DC: Department of Transportation, National Highway Traffic Safety Administration, NHTSA (available on NHTSA website - www.nhtsa.dot.gov).

Brühning E and Berns S (1998). *Definitions and data availability - Compilation and evaluation of A-level roads and hospitalised victims in OECD countries, Accident and injury definitions.* Operational Committee of IRTAD Special Report. Germany: Federal Highway Research Institute (BASt). (Document available as http://www.bast.de/htdocs/fachthemen/irtad/utility/special_rep_definitions.pdf)

Bunketorp O, Romanus B, Hansson T, Aldman B, Thorngren L and Eppinger R H (1983). *Experimental study of a compliant bumper system.* Paper number 831623, Proceedings of the 27th Stapp Car crash conference. San Diego California, USA, 17-19 October 1983. Warrendale Pennsylvania, USA: Society of Automotive Engineers, Inc. pp. 287-298.

CARE. Website: http://europa.eu.int/comm/transport/home/care/index_en.htm

Chinn B P and Holding P (2003). *A guide to assessing active adaptive secondary safety systems.* TRL Report TRL567. Crowthorne: TRL Limited.

Commission of the European Communities (2003). *Proposal for a Directive of the European Parliament and of the Council on the approval of motor vehicles and their trailers, and of systems, components and separate technical units intended for such vehicles.* Document dated 14 July 2003, reference COM(2003) 418 final. Brussels: Commission of the European Communities. (Document available from <http://europa.eu.int/comm/enterprise/automotive/directives/proposals.htm>)

Commission of the European Communities (2004). *Commission Decision of 23 December 2003 on the technical prescriptions for the implementation of Article 3 of Directive 2003/102/EC of the European Parliament and of the Council relating to the protection of pedestrians and other vulnerable road users before and in the event of a collision with a motor vehicle and amending Directive 70/156/EEC.* 2004/90/EC. Official Journal of the European Union, L 31, 4.2.2004, p21. Brussels: European Commission. (Document available from <http://europa.eu.int/comm/enterprise/automotive/pagesbackground/pedestrianprotection/index.htm>)

Davies R G (1998). *Addendum. Discussion of research into pedestrian protection costs and benefits.* Report No. 98-456502-02 to the Commission of the European Communities. Nuneaton, UK: Motor Industry Research Association.

Davies R G and Clemo K C (1997). *Study of research into pedestrian protection costs and benefits.* Report No. 97-456502-01 under Contract No. ETD/96/84099 to the Commission of the European Communities. Nuneaton, UK: Motor Industry Research Association.

Department for Transport (2003). *Highways Economic Note No.1 2002.* London: Department for Transport. (Document available at http://www.dft.gov.uk/stellent/groups/dft_rdsafety/documents/sectionhomepage/dft_rdsafety_page.hcsp)

Economic Commission for Europe (1980). *Uniform provisions concerning the approval of vehicles with regard to their front and rear protective devices ("Bumpers etc").* ECE Regulation 42: Revision 1. Geneva: United Nations.

Euro NCAP (2001). *Annex to brochure – Phase 9 test results.* European New Car Assessment Programme.

Euro NCAP (2003). *Pedestrian testing protocol (version 4.0).* European New Car Assessment Programme (available on Euro NCAP website – www.euroncap.com).

European Enhanced Vehicle-safety Committee (1998). *EEVC Working Group 17 report. Improved test methods to evaluate pedestrian protection afforded by passenger cars.* Delft, The Netherlands: TNO Crash-Safety Research Centre.

European Enhanced Vehicle-safety Committee (2002). *EEVC Working Group 17 document. Updates, recommendations and further topics for consideration/research with respect to the 1998 EEVC pedestrian safety test methods.* EEVC WG17/Doc 198/rev3.

European Experimental Vehicles Committee (1994). *EEVC Working Group 10 report. Proposals for methods to evaluate pedestrian protection for cars.* Delft, The Netherlands: TNO Crash-Safety Research Centre.

European Parliament and Council of the European Union (1997). *Directive 96/79/EC of the European Parliament and of the Council of 16 December 1996 on the protection of occupants of motor vehicles in the event of a frontal impact and amending Directive 70/156/EEC.* Official Journal of the European Union, L 018, 21/07/1997, p7. Brussels: European Commission. (Document available as http://europa.eu.int/smartapi/cgi/sga_doc?smartapi!celexapi!prod!CELEXnumdoc&lg=en&numdoc=31996L0079&model=guichett)

European Parliament and Council of the European Union (2003). *Directive 2003/102/EC of the European Parliament and of the Council of 17 November 2003 relating to the protection of pedestrians and other vulnerable road users before and in the event of a collision with a motor vehicle and amending Council Directive 70/156/EEC.* Official Journal of the European Union, L 321, 6.12.2003, p15. Brussels: European Commission. (Document available as http://europa.eu.int/eur-lex/pri/en/oj/dat/2003/l_321/l_32120031206en00150025.pdf)

European Transport Safety Council (2000). *Safer car fronts for pedestrians and cyclists - benefits from EEVC procedures.* Brussels: European Transport Safety Council.

Fredriksson R, Håland Y and Yang J (2001). *Evaluation of a new pedestrian head injury protection system with a sensor in the bumper and lifting of the bonnet's rear edge.* Proceedings of the 17th international technical conference on the Enhanced Safety of Vehicles, Amsterdam, The Netherlands, 4-7 June 2001. Washington DC: Department of Transportation, National Highway Traffic Safety Administration, NHTSA (available on NHTSA website - www.nhtsa.dot.gov).

Glaeser K P (1991). *Development of a Head Impact Test Procedure for Pedestrian Protection.* BASt report under contract No. ETD/89/7750/M1/28 to the European Commission.

Gray H (1918). *Anatomy of the Human Body*. Philadelphia: Lea & Febiger, 20th edition, revised and re-edited by Lewis W. H. [On-line edition, Bartleby.com, Inc. 2000 (available on website www.bartleby.com)].

Gray H (2001). *Anatomy, descriptive and surgical*. Hoo, Kent UK: Grange Books, A facsimile, 2001.

Green J and Young A (1998). *Head impact speeds from MADYMO simulations of impacts with different sized pedestrians*. Rover Group committee paper for EEVC WG17, April 1998, EEVC WG17 / Doc 33 rev1. Rover Group.

Holding P N, Chinn B P and Happian-Smith J (2001). *Pedestrian protection – an evaluation of an airbag system through modelling and testing*. Proceedings of the 17th international technical conference on the Enhanced Safety of Vehicles, Amsterdam, The Netherlands, 4-7 June 2001. Washington DC: Department of Transportation, National Highway Traffic Safety Administration, NHTSA (available on NHTSA website - www.nhtsa.dot.gov).

Hopkin J M and Simpson H F (1995). *Valuation of road accidents*. TRL Report TRL163. Crowthorne: TRL Limited.

IHRA Pedestrian Safety Working Group (2001). *International Harmonized Research Activities Pedestrian Safety Working Group. 2001 report*. Document IHRA/PS/200. Tokyo, Japan: Japan Automobile Standards Internationalization Center. (Document available at <http://www-nrd.nhtsa.dot.gov/ihra/Pedestrian/pedestrian.html>)

International Organization for Standardization, 2003a. *Pedestrian impact test procedure – child head protection*. Document ISO/CD 16850, stage date 2003-10-08. Geneva: International Organization for Standardization.

International Organization for Standardization, 2003b. *Road vehicles – pedestrian protection – head impact test method*. Document ISO/DIS 14513, stage date 2003-11-20. Geneva: International Organization for Standardization.

Jacobs G, Aeron-Thomas A and Astrop A (2000). *Estimating global road fatalities*. TRL Report TRL445. Crowthorne, UK: TRL Limited.

Janssen E G and Nieboer J J (1990). *Protection of vulnerable road users in the event of a collision with a passenger car, part I - Computer simulations*. TNO report No: 75405002/I December 1990. Delft, The Netherlands: TNO Crash-Safety Research Centre.

Kajzer J, Matsui Y, Ishikawa H, Schroeder G and Bosch U (1999). *Shearing and bending effect at the knee joint at low speed lateral loading*. Paper number 1999-01-0712, Occupant Protection SAE SP-1432. Warrendale Pennsylvania, USA: Society of Automotive Engineers, Inc.

Kajzer J, Schroeder G, Ishikawa H, Matsui Y and Bosch U (1997). *Shearing and bending effects at the knee joint at high speed lateral loading*. Paper 973326, Proceedings 41st Stapp Car Crash Conference, Lake Buena Vista, Florida, USA, November 1997. Warrendale Pennsylvania, USA: Society of Automotive Engineers, Inc. pp. 151-166.

Kalliske I and Friesen F (2001). *Improvements to pedestrian protection as exemplified on a standard-sized car*. Proceedings of the 17th international technical conference on the Enhanced Safety of Vehicles, Amsterdam, The Netherlands, 4-7 June 2001. Washington DC: Department of Transportation, National Highway Traffic Safety Administration, NHTSA (available on NHTSA website - www.nhtsa.dot.gov).

Kerr J (2002). *Head-up displays*. www.canadiandriver.com (available at www.canadiandriver.com/articles/jk/021016.htm).

Konosu A (2004). Personal communication

Konosu A, Ishikawa H and Tanahashi M (2001). *Reconsideration of injury criteria for pedestrian subsystem legform test – problems of rigid legform impactor*. Proceedings of the 17th international

technical conference on the Enhanced Safety of Vehicles, Amsterdam, The Netherlands, 4-7 June 2001. Washington DC: Department of Transportation, National Highway Traffic Safety Administration, NHTSA (available on NHTSA website - www.nhtsa.dot.gov).

Konosu A and Tanahashi M (2003). *Development of a biofidelic flexible pedestrian legform impactor.* Stapp car crash journal, Volume 47: Papers presented at the 47th Stapp car crash conference, San Diego California, 27-29 October 2003. Warrendale Pennsylvania, USA: Society of Automotive Engineers, Inc. (SAE).

Kuehn M, Froeming R and Schindler V (2003). *An advanced testing procedure for the pedestrian-car-collision.* Proceedings of the 18th international technical conference on the Enhanced Safety of Vehicles, Nagoya Japan, 19-22 May 2003. Washington DC: Department of Transportation, National Highway Traffic Safety Administration, NHTSA (available on NHTSA website - www.nhtsa.dot.gov).

Lawrence G J L (1990). *The influence of car shape on pedestrian impact energies and its application to sub-system tests.* Proceedings Twelfth International Technical Conference on Experimental Safety Vehicles, Gothenburg, Sweden, May 1989. USA: US Department of Transportation. pp 1253-1265.

Lawrence G J L (1998). *The upper legform test explained and justified.* TRL committee paper for EEVC WG17, 28/29 January 1998, EEVC WG17 / Doc 35. Crowthorne, UK: TRL Limited.

Lawrence G J L and Hardy B J (2002). *Reconsideration of the dynamic certification test for the EEVC WG17 legform impactor.* Unpublished Project Report PR/SE/520/02. Crowthorne, UK: TRL Limited.

Lawrence G J L, Hardy B J and Donaldson W M S (2002). *Costs and effectiveness of the Honda Civic's pedestrian protection, and benefits of the EEVC and ACEA test proposals.* Project Report PR/SE/445/02. Crowthorne, UK: TRL Limited.

Lawrence G J L, Hardy B J and Donaldson W M S (2004). *Evaluation of the leaf spring certification test for the EEVC WG17 legform impactor.* Project Report PR/SE/900/04. Crowthorne, UK: TRL Limited. (*Report is currently a draft and hence is not yet available.*)

Lawrence G J L, Hardy B J and Lowne R W (1993). *Costs and benefits of the EEVC pedestrian impact requirements.* Project Report PR19. Crowthorne, UK: TRL Limited.

Lawrence G J L and Rodmell C B (2000). *Assessment of the damped, production version of the TRL pedestrian legform impactor.* Project Report PR/SE/030/00. Crowthorne, UK: TRL Limited.

Lawrence G J L and Thornton S T (1996). *The development and evaluation of the TRL legform impactor.* Project Report PR/VE/189/96. Crowthorne, UK: TRL Limited.

Maki T, Asai T and Kajzer J (2003). *Development of future pedestrian protection technologies.* Proceedings of the 18th international technical conference on the Enhanced Safety of Vehicles (ESV), Nagoya, Japan, 19-22 May 2003. (Document available at <http://www-nrd.nhtsa.dot.gov/departments/nrd-01/esv/esv.html>).

Matsui Y (2001). *Biofidelity of TRL legform impactor and injury tolerance of the human leg in lateral impact.* Stapp car crash journal, Volume 45: Papers presented at the 45th Stapp car crash conference, San Antonio Texas, 15-17 November 2001. Warrendale Pennsylvania: Society of Automotive Engineers, Inc. (SAE). pp. 495-510.

Matsui (2003). *New injury reference values determined for TRL legform impactor from accident reconstruction test.* International Journal of Crashworthiness, 8 (2) 89-98.

Matsui Y, Ishikawa H and Sasaki A (1998). *Validation of pedestrian upper legform impact test – reconstruction of pedestrian accidents.* Proceedings of the 16th international technical conference on the Enhanced Safety of Vehicles, Windsor Ontario, Canada, 31 May - 4 June 1998. Washington DC: Department of Transportation, National Highway Traffic Safety Administration, NHTSA (available on NHTSA website - www.nhtsa.dot.gov).

- Matsui Y, Sasaki A, Wittek A, Takabayashi M, Jimbo H, Tanahashi M, Niimura K and Ozawa Y (2003).** *Development of JAMA-JARI pedestrian child and adult head-form impactors.* Proceedings of the 18th international technical conference on the Enhanced Safety of Vehicles, Nagoya Japan, 19-22 May 2003. Washington DC: Department of Transportation, National Highway Traffic Safety Administration, NHTSA (available on NHTSA website - www.nhtsa.dot.gov).
- Mazda (2004).** *News from Mazda.* Available on Mazda Motor Corporation website – www.mazda.com.
- Mertz H J (1993).** *Anthropomorphic test devices.* In: *Accidental Injury - Biomechanics and Prevention.* (Eds A M Nahum and J W Melvin.) New York: Springer-Verlag. pp 66-84.
- Mizuno Y (2003).** *Summary of IHRA pedestrian safety WG activities (2003) – proposed test methods to evaluate pedestrian protection afforded by passenger cars.* Proceedings of the 18th international technical conference on the Enhanced Safety of Vehicles, Nagoya Japan, 19-22 May 2003. Washington DC: Department of Transportation, National Highway Traffic Safety Administration, NHTSA (available on NHTSA website - www.nhtsa.dot.gov).
- Mizuno Y and Ishikawa H (on behalf of IHRA Pedestrian Safety WG) (2001).** *Summary of IHRA pedestrian safety WG activities – Proposed test methods to evaluate pedestrian protection afforded by passenger cars.* Paper 280, Proceedings Seventeenth International Technical Conference on the Enhanced Safety of Vehicles, Amsterdam, June 2001. USA: US Department of Transportation. (Document available at <http://www-nrd.nhtsa.dot.gov/departments/nrd-01/esv/esv.html>)
- Neale M S, Hardy B J and Lawrence G J L (2001).** *Development of a biofidelic pedestrian and vehicle model for reviewing the EEVC WG17 upper legform test energies.* Project Report PR/SE/309/01. Crowthorne, UK: TRL Limited.
- Neale M S, Hardy B J and Lawrence G J L (2003).** *Development and review of the IHRA (JARI) and TNO pedestrian models.* Proceedings of the 18th international technical conference on the Enhanced Safety of Vehicles, Nagoya Japan, 19-22 May 2003. Washington DC: Department of Transportation, National Highway Traffic Safety Administration, NHTSA (available on NHTSA website - www.nhtsa.dot.gov).
- NHTSA (1999).** *Code of Federal Regulations 49, Part 581 – Bumper Standard.* United States: Department of Transportation, National Highway Traffic Safety Administration, NHTSA, Government Printing Office (available on GPO website - [/www.gpoaccess.gov/cfr/index.html](http://www.gpoaccess.gov/cfr/index.html)).
- Ramet M, Bouquet R, Bermond F and Caire Y.** *Shearing and bending human knee joint tests in quasi-static lateral load.* Proceedings of the international IRCOBI conference on the biomechanics of impact, Brunnen Switzerland. 13-15 September 1995. Bron France: IRCOBI secretariat.
- Research Council for Automobile Repairs (1995).** *Vehicle design features for low speed impact performance.* Available on RCAR website – www.rcar.org
- Research Council for Automobile Repairs (1999).** *The procedure for conducting a low speed 15km/h offset insurance crash test to determine the damageability and repairability of motor vehicles.* Issue 1, available on RCAR website – www.rcar.org
- Robbins D H (1985).** *Anthropometric specifications for small female and large male dummies (Volume 3).* National Highway Traffic Safety Administration (NHTSA) Contract DTNH22-80-C-07502. Washington, D. C.: NHTSA, Department of Transportation.
- Rodmell C and Lawrence G J L (1998).** *Further pedestrian accident reconstructions with the upper legform impactor.* TRL committee paper for EEVC WG17, 26-27 November 1998, EEVC WG17 / Doc 113. Crowthorne, UK: TRL Limited..
- Simon T (1998).** *'Night sight' technology has drivers seeing (infra) red.* Website of the Discovery Channel Canada (available at www.exn.ca/Stories/1998/09/14/55.asp).
- Simpson H F (1996).** *Comparison of hospital and police casualty data: a national study.* TRL Report TRL173. Crowthorne, UK: TRL Limited.

Stevens A, Jonas R, Breslin C and Mulvanny P (1998). *Evaluation of flat panel display technologies for an automotive night vision enhancement HUD system.* University of Strathclyde (available at www.mis.strath.ac.uk/predict/staff/cbreslin/pubs/nvs.pdf).

Takahashi Y and Kikuchi Y (2001). *Biofidelity of test devices and validity of injury criteria for evaluating knee injuries to pedestrians.* Proceedings of the 17th international technical conference on the Enhanced Safety of Vehicles, Amsterdam, The Netherlands, 4-7 June 2001. Washington DC: Department of Transportation, National Highway Traffic Safety Administration, NHTSA (available on NHTSA website - www.nhtsa.dot.gov).

Transport Canada (1978). *Motor Vehicle Safety Act: Motor Vehicle Safety Regulations, Standard 215.* Transport Canada (available on Transport Canada website – www.tc.gc.ca/acts-regulations).

van Kampen L T B (1994). *Cost-benefit study concerning car front impact requirements to increase the crash-safety of pedestrians and cyclists.* Report R-94-31. Leidschendam, The Netherlands: SWOV Institute for Road Safety Research.