



Marine Strategy Framework Directive (MSFD)
Common Implementation Strategy

22nd Meeting of the Marine Strategy Coordination Group (MSCG)

23 April 2018, 09:00 – 17:30

Conference Centre Albert Borschette (36, rue Froissart, B- 1040 Brussels, room 0C)

Agenda item:	4a
Document:	MSCG_22-2018-03
Title:	Reporting on the 2018 update of articles 8, 9 & 10 for the Marine Strategy Framework Directive (version 5)
Prepared by:	European Environment Agency and DG Environment
Date prepared:	09/04/2018
Background:	<p>This guidance and associated reporting tools have been prepared to support the updating of MSFD Articles 8, 9 and 10 which, according to MSFD Article 17, are due to be notified by Member States to the Commission by 15 October 2018.</p> <p>The guidance has been developed in collaboration with WG DIKE, and with input from WG GES and WG POMESA, as follows:</p> <ul style="list-style-type: none"> • Dec. 2016 - Concept paper (DIKE_13-2016-03) • Mar. 2017 – Guidance v1.0 (DIKE_14-2017-02) • Apr. 2017 – Guidance v2.1 (DIKE_15-2017-02) – joint with WG GES and POMESA • Jun. 2017 – Guidance v3.0 (DIKE_15-2017-02rev2) – distributed to WG DIKE • Jun. 2017 – Guidance v4.0 (DIKE_15-2017-02rev3) – distributed to MSCG • Sep. 2017 – Guidance v4.1 (DIKE_16-2017-02) • Nov. 2017 – Training day for Member States • Nov.-Dec. 2017 – first test phase for reporting tools • Feb. 2018 – Guidance v4.2 (DIKE_17-2018-02) • Feb.-Mar. 2018 – second test phase for reporting tools • Mar. 2018 – Guidance annex 1 updated worked examples (GES_19-2018-07) • Apr. 2018 – Guidance v5.0 (MSCG_22-2018-03) - this paper

MSCG is invited to:

- a) Adopt the Reporting guidance and associated tools (schemas, web forms and Access database) for their use in the 2018 reporting exercise.



Marine Strategy Framework Directive (MSFD)
Common Implementation Strategy

**Reporting on the 2018 update of articles 8, 9 & 10 for the
Marine Strategy Framework Directive**

MSFD GUIDANCE DOCUMENT 14

VERSION 5 - APRIL 2018

Further guidance for reporting, including use of the MSFD web reporting tool and schemas is available from: <http://cdr.eionet.europa.eu/help/msfd>.

Disclaimer:

This document has been developed through a collaborative programme involving the European Commission, all EU Member States, the Accession Countries, and Norway, international organisations, including the Regional Sea Conventions and other stakeholders and Non-Governmental Organisations. The document should be regarded as presenting an informal consensus position on best practice agreed by all partners. However, the document does not necessarily represent the official, formal position of any of the partners. Hence, the views expressed in the document do not necessarily represent the views of the European Commission.

Recommended citation:

European Commission. 2018. *Reporting on the 2018 update of articles 8, 9 & 10 for the Marine Strategy Framework Directive*. DG Environment, Brussels. pp 71 (MSFD Guidance Document 14).

Contents

1	Introduction	6
1.1	Reporting requirements in 2018 under the MSFD.....	6
1.2	How the Commission will use the reported information.....	6
2	Content of reports	6
2.1	Overview of the articles to be reported.....	6
2.2	Reporting package.....	9
2.2.1	XML files	9
2.2.2	Indicator assessments	10
2.2.3	Supporting data	11
2.2.4	Text-based reports	11
2.2.5	Regional quality status reports.....	13
2.3	Illustrative examples	13
2.3.1	Integrated reporting.....	13
2.3.2	Article 8 assessments outputs.....	14
3	Information to be reported	17
3.1	Marine Reporting Unit.....	17
3.2	Features and elements assessed.....	18
3.3	Article 9: GES determination	19
3.4	Article 8(1a, b): assessments against GES	19
3.5	Article 8(1c): economic and social analysis.....	22
3.6	Article 10: environmental targets	23
3.7	Indicators.....	24
3.8	Metadata of the reporter	24
4	Quality Control specifications	25
5	Links to other policy processes (WFD, CFP, RSC).....	25
6	Reporting process: steps	26
7	Procedures and format for reporting	26
7.1	Technical support for reporting	26
7.2	Reporting language	27
7.3	Formal notification	27
ANNEX I: Relationship between Decision (EU) 2017/848 criteria and the criteria and indicators in Decision 2010/477/EU		29
ANNEX II: Illustrative examples of Article 9 and Article 8 (1a, b) reporting outputs.....		31
ANNEX III: Schemas		32
a)	ART9_GES	32

b)	ART8_GES	35
c)	ART8_ESA	42
d)	ART10_Targets	45
e)	Indicators.....	48
ANNEX IV: Enumeration lists.....		50
a)	CountryCode_Enum	50
b)	Feature_Enum	50
c)	GEScomponent_Enum.....	56
d)	IntegrationRule_Enum	57
e)	MarineLitterCategories_Enum	59
f)	Parameters_Enum	59
g)	ThresholdSources_Enum.....	63
h)	Units_Enum	64
i)	ElementCodeSource	65
j)	NACECodes_Enum (indicative).....	66
ANNEX V: Common indicator structure		67
a)	Common Indicator: XML elements annotated	67
b)	Mapping between 'Indicators' schema elements and the 'Common Indicator Structure' elements.....	69
ANNEX VI: GES assessments to be provided under the ART8_GES schema.....		70

Tables and Figures

Table 1 Schemas for 2018 reporting on MSFD Article 17 updates of Articles 8, 9 and 10.	10
Table 2 Proposed outline of contents for 2018 Article 8, 9 and 10 text-based report.....	11
Table 3 Example for D5 (eutrophication) regarding an integrated view of the articles to be reported	14
Table 4 Simplified example of D3 (commercial fish and shellfish) assessment (grey cells require no information); see Annex II for full version.	15
Table 5 Simplified example of D8 (contaminants) assessment (grey cells require no information); see Annex II for full version.	16
Table 6 Fields on metadata of the reporter	25
Table 7 Fields of the schema 'ART9_GES'	32
Table 8 Fields of the schema 'ART8_GES'	36
Table 9 Fields of the schema 'ART8_ESA'	42
Table 10 Fields of the schema 'ART10_Targets'	45
Table 11 Fields of the schema 'Indicators'	48
Table 12 XML elements of the Common Indicator Structure (MSFD Guidance Document 13).....	67
Figure 1 Main articles to be reported under the MSFD and their interconnections	8
Figure 2 XSD diagram of 'ART9_GES'	32
Figure 3 XSD diagram of 'ART8_GES'	35
Figure 4 XSD diagram of 'ART8_ESA'	42
Figure 5 XSD diagram of 'ART10_Targets'	45
Figure 6 XSD diagram of 'Indicators'	48

LIST OF ACRONYMS

BUCH	Convention on the Protection of the Black Sea Against Pollution
CDR	Central Data Repository
CFP	Common Fisheries Policy
DCF	Data Collection Framework (CFP)
DPSIR	Drivers, Pressures, State, Impact and Response (assessment framework)
EC	European Commission
EEA	European Environment Agency
EIONET	European Environment Information and Observation Network
ETC-ICM	European Topic Centre on Inland, Coastal and Marine Waters
EU	European Union
EUNIS	European nature information system
GES	Good Environmental Status (MSFD Articles 3(5) and 9)
GIS	Geographical information system
HD	Habitats Directive
HELCOM	Convention on the Protection of the Marine Environment of the Baltic Sea Area
ICES	International Council for the Exploration of the Sea
INSPIRE	Infrastructure for Spatial Information in the European Community
MRU	Marine Reporting Unit
MS	Member States
MSFD	Marine Strategy Framework Directive
OSPAR	Convention for the Protection of the Marine Environment of the North-East Atlantic
PoM	Programme of Measures (MSFD Article 13)
QA	Quality assurance
QC	Quality control
ReportNet	Eionet's infrastructure for supporting data flows (e.g. by Member States for reporting obligations under an EU Directive)
RSC	Regional Sea Convention
SOS	Sensor Observation Service
UNEP/MAP	Convention for Protection of the Mediterranean Sea against Pollution (United Nations Environment Programme - Mediterranean Action Plan)
WFD	Water Framework Directive
WFS	Web Feature Service
WMS	Web Map Service
WISE	Water Information System for Europe
XML	Extensible Mark-up Language

Marine Strategy Framework Directive (MSFD)

Common Implementation Strategy

Reporting on the 2018 update of articles 8, 9 & 10 for the Marine Strategy Framework Directive

1 Introduction

1.1 Reporting requirements in 2018 under the MSFD

According to article 17(2) of the Marine Strategy Framework Directive (MSFD), Member States (MS) have to update their marine strategies every six years. This requires articles 8 (initial assessment), 9 (determination of the Good Environmental Status) and 10 (establishment of targets) to be updated by 15 July 2018, and notified to the European Commission (EC) by 15 October 2018 at the latest.

This reporting guidance has been developed with the aim of assisting and facilitating this 2018 reporting obligation by MS in their implementation of the Directive. As far as possible, the results of and the recommendations from the Fitness Check on environmental reporting and monitoring¹ have been considered in preparing this reporting guidance, e.g. taking into consideration indicators, reducing text-based reporting and making reference to information that is available at national or regional level.

1.2 How the Commission will use the reported information

The information provided by the MS will be used by the European Commission for assessing whether the elements notified are consistent with the requirements of the MSFD in each Member State (i.e. compliance assessment), as well as the coherence of frameworks within the different marine regions or subregions and across the Union. Also, it will serve the preparation of reports, for example for the European Parliament, Council and the general public, on the implementation of the MSFD and to show the progress towards achieving Good Environmental Status (GES) of Europe's seas.

In addition, the European Environment Agency (EEA) will use the information provided to perform its tasks under MSFD article 20(3b) and to contribute to its assessments.

All the information reported will be made publicly available through WISE-marine², a web-based content management system that will show the efforts made across Europe on the implementation of the MSFD and the current state of the marine environment in relation to Good Environmental Status (GES). A more detailed definition of reporting products, including the preparation of country-specific information, is under development and discussion in WG DIKE.

2 Content of reports

2.1 Overview of the articles to be reported

The preparation of articles 8, 9 and 10 in 2012 provided the basis and starting point for the Member State's marine strategies, upon which the monitoring programmes (art. 11) and the programmes of measures (art. 13) were built in 2014 and 2015 respectively. According to Article 17, the information

¹ http://ec.europa.eu/environment/legal/reporting/fc_overview_en.htm

² <https://water.europa.eu/marine>

reported on these three articles in the first cycle of the MSFD needs to be updated in 2018, taking account of progress made since the last reporting in 2012, including:

- a. The outcomes of the EC's assessment of the 2012 reports³;
- b. Establishment of monitoring programmes (article 11) in 2014 which aim, *inter alia*, to collect data and information to assess progress towards achieving GES and targets;
- c. Commission Decision (EU) 2017/848 on GES criteria and methodological standards, which replaces Decision 2010/477/EU. This revised Decision provides the basis for updating the determinations of GES and for assessing the extent to which GES is being achieved⁴;
- d. Commission Directive (EU) 2017/845 which amends the MSFD by replacing its Annex III⁵;
- e. Relevant assessments undertaken under other EU policies and international conventions;
- f. Advancements in scientific and technical knowledge and in methods for assessment.

Article 9 of the Directive requires MS to determine, in respect of each marine region or subregion concerned, a set of characteristics for GES on the basis of the qualitative descriptors listed in Annex I of the Directive.

Commission Decision 2010/477/EU provided the criteria to be used by MS to assess the extent to which GES is being achieved, and thus formed the basis for the determinations of GES in 2012. However, this Decision has been replaced by a new Decision which was adopted in May 2017. MS are to use the new Decision for the update of their marine strategies in 2018, to the extent possible. The new Decision provides more detail per criterion than the 2010 Decision, including *inter alia*, a) prioritisation of criteria, b) scales of assessment, c) how to derive the extent to which GES is achieved, d) when it is expected to use the assessments coming from the coastal and territorial waters (as defined under the Water Framework Directive) regarding eutrophication and contamination and other assessments, e) criteria for selecting the species and habitats to be assessed, and f) units of measurement for each of the criteria.

In view of this transition period between application of the 2010 and 2017 GES Decisions, the 2018 reporting system will accommodate the possibility of reporting based on the 2010 Decision. A mapping of the 2010 Decision and the revised one is provided in [Annex I](#), where the elements from the old Decision that are not covered by the new one have also been included and will be available for selection in the reporting tools.

Article 8 of the Directive requires MS to make an assessment of their marine waters. The update of this assessment in 2018 should take account of the data resulting from the monitoring programmes defined in the first cycle (2014, article 11), as well as assessments coming from other processes, such as the Regional Sea Convention (RSC) assessments, or Directives such as the Water Framework Directive (WFD). The assessment comprises three elements:

- An analysis of the predominant essential features and characteristics, and the current environmental status of their marine waters (Art 8(1a)). This analysis should be based on the indicative list of characteristics set out in Table 1 of the revised Annex III of the Directive. The

³ <http://eur-lex.europa.eu/legal-content/EN/TXT/?uri=COM:2014:0097:FIN>

⁴ Commission Decision laying down criteria and methodological standards on good environmental status of marine waters and specifications and standardised methods for monitoring and assessment, and repealing Decision 2010/477/EU. <http://eur-lex.europa.eu/legal-content/EN/TXT/?qid=1495097018132&uri=CELEX:32017D0848>.

⁵ Commission Directive amending Directive 2008/56/EC of the European Parliament and of the Council as regards the indicative lists of elements to be taken into account for the preparation of marine strategies. <http://eur-lex.europa.eu/legal-content/EN/TXT/?qid=1495097018132&uri=CELEX:32017L0845>.

analysis should cover the physical and chemical features, the habitat types, the biological features and the hydro-morphology.

- An analysis of the predominant pressures and impacts, including human activity, on the environmental status of those waters (Art 8(1b)), based on the list of elements in Table 2 of the revised Annex III of the Directive (including the updated list of pressures in Table 2a and the new list of uses and human activities in Table 2b).
- An economic and social analysis of the use of the marine waters, and of the cost of degradation of the marine environment (Art 8(1c)), based on the list of uses and human activities marked with an * in Table 2b of the revised Annex III.

Compared with 2012, in which the reporting provided an incomplete and inconsistent set of assessments on the state of the marine waters at that time, it is essential that the updated reports in 2018 for Article 8(1a) and (1b) provide clear and specific information on the current status of the marine waters in order to determine the progress towards achieving GES. The specifications for this are laid out in the GES Decision (2017) and thus form the basis of the reporting described here.

Article 10 of the Directive requires that, on the basis of their initial assessment, MS establish a comprehensive set of environmental targets and associated indicators for their marine waters. The aim of the targets and indicators is to guide progress towards achieving GES in the marine environment, taking into account the indicative lists of pressures and impacts set out in Table 2a of the revised Annex III to the Directive and of characteristics set out in MSFD Annex IV.

The updating of Article 10 provides MS with the opportunity to assess progress with each of the targets defined in 2012 (or in some cases revised later following the Commission's recommendations in the 2014 Article 12 assessment). It is also possible to reflect on the appropriateness of the targets, which in some cases were more compatible with GES determinations under Article 9, and to add new targets if deemed necessary. Lastly, MS developed their Programmes of Measures (Article 13, reporting due March 2016) in order to deliver their environmental targets and hence to help achieve GES; the 2018 updates should provide a link back to these measures, thereby ensuring linkages between the different stages in the marine strategies.

Figure 1 represents the main articles to be reported under the MSFD, as well as the logical connections among them. In white, are the articles to be reported in 2018, while the articles in grey fall under other MSFD reporting obligations.

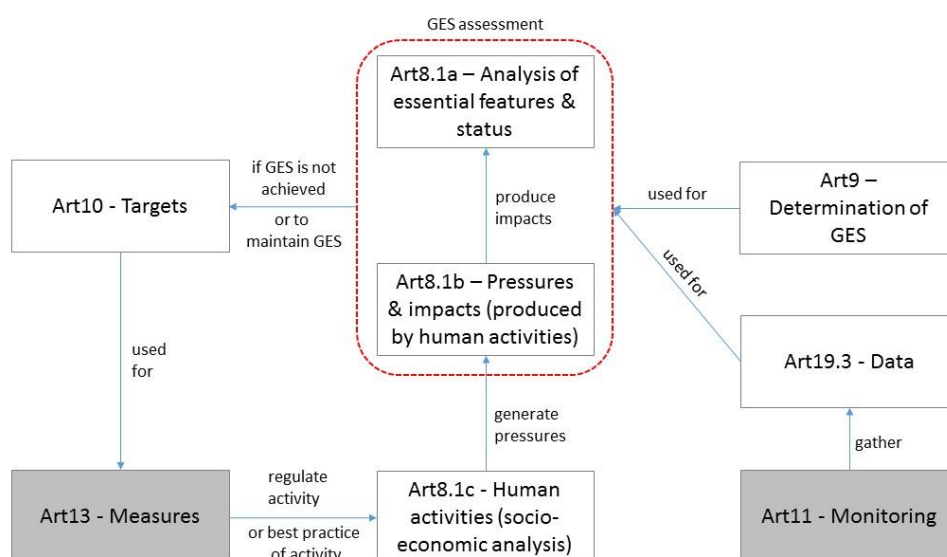

Figure 1 Main articles to be reported under the MSFD and their interconnections

2.2 Reporting package

The reporting package in 2018 comprises:

- a. structured reporting of information via XML;
- b. regional and national indicator assessments that are made available online;
- c. the supporting assessment data sets, made available online as per MSFD Article 19(3);
- d. in addition text-based national reports and, where appropriate, regional 'roof' reports may be submitted.

The XML files and associated indicator reports, including associated data sets, aim to include all the information considered necessary for the EC and EEA to perform their assessments, and to help MS implement their own policies.

2.2.1 XML files

The Commission's Article 12 assessment of the 2012 reporting, together with feedback from MS on the 2012 reporting process, showed that improvements should be made for the subsequent reporting exercises, such as:

- Requesting more quantitative information where possible, which avoids ambiguity in interpretation of the information and allows for its aggregation for statistical and dissemination (European, regional and national) purposes;
- Easing the reporting process for MS (e.g. fewer reporting fields, automation as far as possible, code lists for the main variables) and the national policy process by provision of reporting tools;
- Possibility to link to the assessment reports performed under other relevant instruments (e.g. WFD) and to regional assessment reports and indicators performed under the RSCs.

In order to address these issues, a new data model has been developed and forms the basis for the schemas to be used to produce the XML files for the 2018 reporting.

MS will have three possible ways to prepare the XML files:

- a. to generate XML files themselves, based on the schemas (e.g. from a national database);
- b. to compile the information in an Access database and convert it to XML files (Access database and a converter will be made available in CDR website); or
- c. to use web-forms⁶ that will produce the XML files.

In all cases, the XML files need to be uploaded to the corresponding country folder in CDR⁷.

These options (use of web-forms and preparation of XML files) are the same as followed for reporting on MSFD Articles 11 and 13 in 2014 and 2016 respectively.

All the tools, as well as the present Reporting guidance, are available in the MSFD reporting resources page under CDR help⁸.

Before releasing an envelope with XML files in ReportNet, there will be the possibility of running a Quality Assurance check, to ensure that there are no errors in the files. This is the same QA routine

⁶ The web-forms are not completely functional when using Internet Explorer. The use of other browsers is recommended.

⁷ <http://cdr.eionet.europa.eu/>

⁸ <http://cdr.eionet.europa.eu/help/msfd>

that will be run when releasing the envelope to ensure that the deliveries from Member States have the required quality. The QA specifications are available in the MSFD reporting resources page.

The schemas in Table 1 have been developed for the 2018 reporting. Detailed guidance is provided in [Annex III](#). There should be separate reports per subregion, but held in the same XML file. In order to help the Member States to prepare a single file per schema, a “Merge” tool has been developed and made available in the CDR help page.

Table 1 Schemas for 2018 reporting on MSFD Article 17 updates of Articles 8, 9 and 10.

Schema name	Number of files needed	Contents
ART9_GES	1 file per MS	GES determination
ART8_GES	1 file per MS	Assessment results concerning current status of marine waters and the predominant pressures and environmental impacts of human activities
ART8_ESA	1 file per MS	Socio-economic analysis of the uses of marine waters and the costs of degradation
ART10_Targets	1 file per MS	Targets and associated indicators, including an assessment on the progress towards achieving them
Indicators	1 file per MS	Basic information on the indicators used by the MS (national or regional) for the assessments, including links to where published and to underlying datasets

2.2.2 Indicator assessments

The Article 8 assessments on state and pressures, indicating progress towards achieving GES, and on the economic and social analysis, are typically informed by indicator assessments which draw from the available monitoring data in a structured manner for each assessment topic. The indicators can cover all aspects of the DPSIR framework, where there may be indicators related to the analysis of the main characteristics, others related to the analysis of pressures and impacts and others related to the socioeconomic analysis. Similarly, progress in achieving the Article 10 targets is to be measured through associated indicators. Typically, the indicator assessments provide detailed information including the matrices, metrics and methods used, as well as the results. Selected information from each indicator assessment (e.g. elements assessed, values and trends) can be used to populate the XML reports.

Since 2012, considerable efforts have been made in each region to coordinate the development of indicators suited to the needs of MSFD assessments. Indicators have thus become the basis of the assessments performed at the regional level. Indicators are not yet available at the regional level for all MSFD topics in all regions. Where these regional indicators are not yet available, Member States use those available at national level.

Therefore, these indicator assessments have been incorporated as a key piece of the 2018 reporting. It is expected that Member States will make use of those regional indicators that are relevant for their waters, whilst complementing these with additional national indicators, where needed.

Where indicator assessments are made available on regional or national web sites, the URL link will be requested in the [indicator schema](#), to provide access to all the information related to the indicator assessment, including the methodologies, data sets used and results. Provision of a URL link avoids the need to directly report the entire indicator assessment. Several RSCs are making their indicator assessments available online.

The reporting on articles 8 and 10 will request the code of the corresponding indicator(s) used for each feature assessment, thereby linking to the indicator schema.

To facilitate consistency in the presentation of indicator assessments across a wide range of topics and regions/countries, a *common indicator structure* was developed by the MSFD Common Implementation Strategy (CIS), in collaboration with the Regional Sea Conventions (Guidance

Document 13⁹). Member States are encouraged to use the *common indicator structure*, whenever possible.

[Annex V](#) of the present guidance includes a schema following the *common indicator structure* for the publication of these indicators. Use of this schema would allow the possibility of including the regional and national indicators into a WISE-marine indicators library (i.e. to have the indicator assessment displayed in WISE-Marine). The annex includes also the mapping of the fields to the 'Indicators' schema to be reported. Member States may use the schema for future link-up to WISE-Marine. It is expected that the schema for the *common indicator structure* will have limited use in 2018 reporting, but could be introduced over time.

2.2.3 Supporting data

The datasets used for the assessments are to be made available, as set out in MSFD Article 19(3) of the Directive, and in compliance with the INSPIRE Directive "Implementing Rules (IR)".

The MSFD CIS Technical Group on Marine Data (TG DATA) has developed a document on Recommendations for the publication of datasets under Article 19(3), where the relevant INSPIRE elements have been included. This document is also available in the MSFD reporting resources page.

Article 19(3) is to be fulfilled, in respect of data and information resulting from the [updating of] initial assessments made pursuant to Article 8, by publishing the datasets used for the indicators assessments. The URL where the datasets have been published, together with the URL to the metadata of these datasets, are requested in the indicators schema (section 3.7), as well as in the *common indicator structure* ([Annex V](#)).

2.2.4 Text-based reports

Member States typically prepare text-based reports at the national level, using these to serve their public consultation obligations under MSFD Article 19(2) and finalising them so that the Marine Strategies are adopted within their national planning.

In addition to the XML files and associated indicator reports and datasets, Member States may submit their national text-based reports as part of their reporting obligation.

Table 2 recommends the contents to be covered in the national text-based reports. The outline follows the elements provided by the MSFD itself and by the revised GES Decision and Annex III and the headlines covered by xml reporting. Member States may use the table of contents to structure their national text reports.

If the Member State has adopted an alternative structure, then a correspondence table between this contents list and that followed in the Member State report is requested to facilitate access to the information by the Commission.

Table 2 Proposed outline of contents for 2018 Article 8, 9 and 10 text-based report

Overall topic	Themes
Introductory sections	Background, general characteristics of the marine waters, process and methodologies for preparation of the report, public consultation, etc.
Objective of the MSFD - Good Environmental Status (Art. 9)	Updated determination of GES, taking account of the 2017 GES Decision to the extent possible
Uses of the marine environment (Art 8 (1c))	Uses and human activities in or affecting the marine environment (MSFD Annex III, Table 2b uses/activities marked with *) Economic and social analysis of uses and human activities:

⁹https://circabc.europa.eu/sd/a/0557a440-3dd7-489c-893e-2062fce7ce5d/GD13_CommonStructureForIndicator-basedAssessments_20160407_Final.doc

Overall topic	Themes
DPSIR: Drivers (activities)	<ul style="list-style-type: none"> Physical restructuring of [rivers,] coastline and seabed Extraction of non-living resources Production of energy Extraction of living resources Cultivation of living resources Transport Urban and industrial uses Tourism and leisure Security and defence Education and research
<p>Pressures and impacts on the marine environment (Art. 8 (1b))</p> <p>DPSIR: Pressures (and environmental impacts)</p>	<p>Anthropogenic pressures and their impacts (GES Decision Part I and MSFD Annex III Table 2a)</p> <p>Biological pressures:</p> <ul style="list-style-type: none"> Introduction or spread of non-indigenous species (D2) Extraction of, or injury to, wild species (includes D3) Other biological disturbances <p>Physical pressures:</p> <ul style="list-style-type: none"> Physical disturbance to the seabed (D6) Physical loss of the seabed (D6) Hydrological changes (D7) <p>Substances, litter and energy pressures:</p> <ul style="list-style-type: none"> Nutrient and organic matter enrichment (D5) Contamination (in environment and seafood) (D8, D9) Litter (D10) Underwater noise and other forms of energy (D11) Climate change
<p>State of the marine environment (Art. 8 (1a))</p> <p>DPSIR: State (including environmental impacts)</p>	<p>Structure, functions and processes of marine ecosystems (GES Decision Part II and MSFD Annex III Table 1)</p> <p>Marine species (D1):</p> <ul style="list-style-type: none"> Birds Mammals Reptiles Fish Cephalopods <p>Marine habitats:</p> <ul style="list-style-type: none"> Pelagic habitats (D1) Benthic habitats (D6, D1) <p>Marine ecosystems, including food webs (D4, D1)</p>
<p>Cost of degradation (Art 8 (1c))</p> <p>DPSIR: Impact (loss of ecosystem services)</p>	<p>Cost of degradation of the marine environment (loss of ecosystem services)¹⁰</p>
<p>Environmental targets to achieve GES (Art. 10)</p> <p>DPSIR: Response (with links to Art. 13 Measures)</p>	<p>Progress in achievement of 2012 environmental targets</p> <p>Update of targets, links to Programme of Measures</p>

¹⁰ Whenever a Member State follows the ‘ecosystem services’ approach

2.2.5 Regional quality status reports

The Regional Sea Conventions have developed or are developing assessments on the status of the marine environment in 2017 and 2018, namely HOLAS II¹¹ (HELCOM), 2017 Intermediate Assessment¹² (OSPAR), Quality Status Report¹³ (Barcelona Convention) and State of Environment Report (Bucharest Convention). These reports include assessments which may contribute directly to the 2018 reporting needs of MS, e.g. by providing (sub)regionally-consistent indicator assessments for relevant topics. These reports may be used by Member States for 2018 MSFD reporting purposes as follows:

- a. To provide relevant information for the XML file (see Section 5);
- b. To provide indicator assessments which can be reported via URL links (section 2.2.2);
- c. To provide information to be incorporated into national text-based reports or to be submitted as a regional 'roof report' (section 2.2.4).

2.3 Illustrative examples

In this section, some examples are provided to show how the XML reporting has been developed and structured via an underlying data model. More examples are included in Annex II.

2.3.1 Integrated reporting

As shown in Figure 1, all the main reporting articles of the MSFD are connected according to a planning logic. Therefore, the reporting should allow each article to be linked according to this overall scheme. These linkages were built into each stage in the reporting of the first cycle; they have now been fully updated through development of an underlying data model on which the 2018 XML schemas are based.

The reporting schemas described here will allow the possibility to make these linkages, as well as the needed QA/QC processes to provide coherence to the information to be submitted by Member States.

Table 3 provides an example of the main outcomes expected from an integrated reporting, where all articles are brought together for planning purposes (note that this is simplified from the schemas).

¹¹ <http://helcom.fi/helcom-at-work/projects/holas-ii/>

¹² <https://oap.ospar.org/en/ospar-assessments/intermediate-assessment-2017/>

¹³ <https://www.medqsr.org/>

Table 3 Example for D5 (eutrophication) regarding an integrated view of the articles to be reported

Art. 9						Art. 8(1a, b)				Art. 10					Art. 13									
What is the policy objective? (GES for MSFD)						Assessment of pressures and impacts Assessment of state, including impacts Current environmental status (in relation to GES)				Targets to achieve GES		Progress with target			Activities affecting target (& GES)?	Actions needed to achieve targets & GES								
Annex I Descriptor	Annex III Pressure / biodiversity element	GES Decision Theme	GES Decision (2017) Criterion	GES Decision (2017) Justification (1 st criteria, delays)	Art. 9(1) MS (sub)regional determination	GES determination date/type	Element assessed (MS specified)	Element: source (EU, regional, national)	Indicator (regional/national) - includes link to datasets	Art.8 assessments	Target	Indicator	Target value to be achieved	Target value achieved	Target achieved?	Activity (Table 2b Annex III)	Measure	Measure source						
Schema:		ART9_GES		ART9_GES		ART8_GES				ART10_Targets					ART13_Measures									
Field in schema:		Feature	GEScomponent	Justification NonUse Justification Delay	GESDescription		DeterminationDate, UpdateType	Element, Element Code	Element Source	Related Indicator	TargetCode, Description	Related Indicator	Target Value	Value Achieved	Target Status	Feature	Related Measures	Policy						
D5	Input of nutrients	Eutrophication	D5C1	Text	Descriptor level: MS (sub)regional text (based on Annex I Descriptor)	Criterion level: MS (sub) regional text (based on 2017 Decision criterion)	YYYYMM Same as last reported determination	DIN	Regional: HELCOM	Concentration in water URL to regional/national indicator and data	Art.8 assessment outputs (see examples in Table 4 and Table 5 and Annex II)	Reduce N by X% or to Z levels (MAI/CART)	Riverine input levels	Reduce by N tonnes/y	Z tonnes/year	Not yet achieved	Agriculture	Reduce fertilizer use	CAP					
																		Urban development	Waste water treatment	UWWTD				
			D5C2	Text		MS (sub) regional text	YYYYMM Modified from last determination	Chlorophyll-a		Concentration in water URL														
			D5C5	Primary criterion not used because xxxxxxxx																				
			D5C3, D5C4, D5C6, D5C7, D5C8			MS (sub) regional text	YYYYMM New determination	-		-														
											Reduce P by Y tonnes		etc.	As above			Urban (detergents)	Domestic products (detergents)	MSFD					
											See pressure targets					State/impact targets (e.g. as reported in 2012) are in effect expressions of GES and are more appropriately reported under Article 9.								

2.3.2 Article 8 assessments outputs

The new GES Decision provides details on how to express the extent to which GES has been achieved for each Descriptor. These Decision specifications are presented here in the form of output tables per Descriptor, based on a common overall structure (ART8_GES schema). They integrate the characteristics of marine environment, indicated in the Annex III MSFD, to provide a logical link at criterion element level between Article 9 and Article 8 assessment. Outputs are expected to be provided at different levels of integration (elements, criteria), depending on the Descriptor. Table 4 and Table 5 show example outputs for D3 (commercial fish and shellfish) and D8 (contaminants) assessments. A full set of examples, covering all descriptors, is provided in [Annex II](#) (embedded spreadsheet). The reporting system has accommodated all kinds of integration levels needed.

Table 4 Simplified example of D3 (commercial fish and shellfish) assessment (grey cells require no information); see Annex II for full version.

Feature	Element assessed	Criterion	Parameter (indicator)	Target level (D3C1, D3C2), threshold value (D3C3)	Values achieved	Unit	Proportion of MRU over which TV is to be achieved	Proportion of MRU over which threshold has been achieved	Unit	Trend	Criterion status	Status of population (element)	Extent to which GES is achieved	Achieving GES by 2020	Methodological standards: source (EU, regional, national)	Main pressures
Feature	Element, ElementCode	GES component	Parameter Related Indicator	Threshold Value	Value Achieved	ValueUnit	Proportion Threshold Value	Proportion Value Achieved	Proportion Unit	Trend	Criterion Status	Element Status	GESExtent Achieved, GESExtent Unit	GES achieved	Integration Rule Description	Related Pressures
Commercially-exploited fish and shellfish	Cod (North Sea, eastern English Channel and Skagerrak stock)	D3C1	Fishing mortality rate	0.31	0.27	annualised rate				Stable	Good	Not good	Proportion of populations in good status: 43% (3 out of 7 populations) Number of populations not assessed: 2	GES expected to be achieved by 2020	EU level (MSFD CIS)	Extraction of species
		D3C2	Spawning stock abundance	150,000	125,000	Tonnes				Improving	Not good					
		D3C3	Age & size distribution	Not yet set							Not assessed					
	Cod (Kattegat stock)	D3C1	Fishing mortality rate	0.31	0.3					Stable	Good	Good D3C3 not assessed				
		D3C2	Spawning stock abundance	70,000	78,000	Tonnes				Deteriorating	Good					
		D3C3	Age & size distribution	Not yet set							Not assessed					
	Plaice (eastern English Channel)	D3C1	Fishing mortality rate	0.25	0.19	annualised rate				Improving	Good	Good				
		D3C2	Spawning stock abundance	25,826	30,000	Tonnes				Improving	Good					
		D3C3	Age & size distribution	0.6	0.4	%				Unknown	Good					
	Lemon sole (North Sea, Skagerrak, Kattegat, eastern English Channel)	D3C1	Fishing mortality rate	0.4	0.6	annualised rate				Stable	Not good	Not good				
		D3C2	Spawning stock abundance	30,000	45,000	Tonnes				Improving	Good					
		D3C3	Age & size distribution	Not yet set							Not assessed					
	Herring (North Sea, Skagerrak, Kattegat, eastern English Channel)	D3C1	Fishing mortality rate	0.33	0.30	annualised rate				Stable	Good	Good D3C3 assessed but no threshold value				
		D3C2	Spawning stock abundance	1.5e+006	1.8e					Stable	Good					
		D3C3	Age & size distribution	Not yet set	32	cm				Stable	Unknown					
Norway lobster (Skagerrak & Kattegat)											Not assessed					
Brown crab (national stock)											Not assessed					

Table 5 Simplified example of D8 (contaminants) assessment (grey cells require no information); see Annex II for full version.

Feature	Element assessed	Criterion	Parameter (indicator)	Threshold value	Value achieved	Unit	Proportion of MRU over which TV is to be achieved	Proportion of MRU threshold has been achieved	Unit for proportion (% km ²)	Trend	Criterion status	Element status	Extent to which GES is achieved	Achieving GES by 2020	Methodological standards: source (EU, regional, national)	Main pressures
Feature	Element, ElementCode	GES component	Parameter Related Indicator	Threshold Value	Values Achieved Upp-Low	Value Unit	Proportion Threshold Value	Proportion Threshold Value Achieved	Proportion Threshold ValueUnit	Trend	Criterion Status	Element Status	GEExtent Achieved, Unit	GES achieved	Integration Rule Description	Related Pressures
Contaminants - UPBT substances	Mercury (and its compounds)	D8C1	Concentration in water	0.06	10.5 – 0.05	µg/L	95	50	% area of MRU achieving threshold value	Improving	Not good	Not good	50% (1 out of 2 substances) in good status	GES expected to be achieved later than 2020; Article 14 exception reported	Regional (RSC)	Input of other substances
	Heptachlor		Concentration in water	2 x 10 ⁻⁵	2.7 x 10 ⁻⁵ – 2.0 x 10 ⁻⁵	µg/L	95	100		Stable	Good	Good				
Contaminants - non UPBT substances	Lead (and its compounds)		Concentration in biota	19	15 - 7	µg/kg ww	95	97		Deteriorating	Good	Good	66% (4 out of 6 substances) in good status	GES expected to be achieved by 2020		
	Dichlorvos		Concentration in water	0.3	0.02 – 0.1	µg/L	95	100		Stable	Good	Good				
	Tributyltin-cation		Concentration in water	Σ = 0.004	Σ = 0.006 – Σ = 0.003	µg/L	95	97		Deteriorating	Good	Good				
	Phenol		Concentration in sediment	99	213 - 80	µg/kg dw	95	65		Stable	Not good	Not good				
Contaminants - other	Caesium-137		Concentration in sediment	4.4	5.3 – 3.5	µg/kg dw	95	70		Stable	Not good	Not good				
Species	<i>Nucella lapillus</i> (dog whelk)		D8C2	Imposex	1	0.95 – 0.75	Mean Vas Deferens Index			<1	% population adversely affected	Improving	Good	Good		
	<i>Mytilus edulis</i> (blue mussel)	Lysosomal membrane stability		8	12 - 9	Min		20	Unknown	Not good	Not good					
Habitats	Offshore circalittoral, mixed sediment	Condition indicator		0.7	0.8 – 0.6	EQR		1.5	Extent in km ² of habitat adversely affected	Improving	Not good	Contributes to D6C5				
	Offshore circalittoral sand	Condition indicator	0.7	0.9 - 0.65	EQR		3.9	Improving	Not good	Contributes to D6C5						
Acute pollution events		D8C3	Duration & spatial extent		24	Days/y		15	Extent in km ² of pressure	Improving	Not good	Triggers use of D8C4				
Species	<i>Sterna dougalii</i> (Roseate tern)	D8C4	Individuals oiled		200	individuals		2	% population adversely affected	Unknown	Not good	Contributes to D1		Acute pollution events		
	<i>Larus marinus</i> (Black-backed gull)		Individuals oiled		5000	individuals		20	Unknown	Not good	Contributes to D1					
Benthic broad habitats	Littoral sediment (including saltmarsh)		Extent affected					35	Extent in km ² of habitat adversely affected	Unknown	Not good	Contributes to D6C5				
	Littoral rock and biogenic reef		Extent affected					10	Unknown	Not good	Contributes to D6C5					

3 Information to be reported

In this section, the specific information to be reported via XML files is described, including a description of the fields that are part of the schemas. Diagrams and tables with details of the schemas are provided in [Annex III](#).

The three articles are linked in the schemas via two common aspects: the area being reported on (Marine Reporting Unit) (section 3.1) and the particular topic being reported (feature) (section 3.2). Each schema also includes fields for the country, reporter and reporting date (section 3.8).

3.1 Marine Reporting Unit

As has been the practice with each previous reporting round, all articles to be reported are linked to a specific Marine Reporting Unit (MRU, previously termed MarineUnit), thereby linking the reported information to a specified part of the marine waters. The MRUs can be of varying sizes, according to the appropriate scale for the different reports (e.g. region, subregion, subdivision, MS waters, WFD coastal waters, etc) as indicated in the new GES Decision by the scale of assessment to be used.

The EEA/ETC-ICM will develop reference layers¹⁴ of Marine Reporting Units to cover the European seas¹⁵, including the following layers:

- a. Regions
- b. Subregions
- c. Subdivisions of the regions and subregions, where available (e.g. from HELCOM and OSPAR)
- d. National part of a region, subregion or subdivision¹⁶
- e. WFD coastal waters / WFD territorial waters/ Beyond territorial waters

All the MRU codes will be inserted into the reporting system, enabling Member States to select the relevant MRUs for each part of the reporting.

The MRUs will also be made available through INSPIRE web services (e.g. WFS) and according to the relevant INSPIRE data model (Area management/restriction/regulation zones & reporting units (AM)).

Following the INSPIRE Report and evaluation¹⁷, the Commission has published a list of priority data sets, which will be amended by adding the MRUs, since it will be a key spatial dataset of relevance for MSFD reporting.

The preparation of the set of MRUs to cover all marine waters will take time to fully establish. In particular, the set of subdivisions (also referred to as 'assessment areas' in previous guidance, 'sub-basins' in HELCOM, etc) used for reporting is more established in the Baltic and Atlantic regions than in the Mediterranean and Black Sea regions. Consequently, until such (sub)regionally agreed subdivisions are in place, it will be possible for MS to use and update their existing national reporting areas. This can be done via updates to the schema '4geo.xml' and provision of associated GIS

¹⁴ As Geographical Information System (GIS) datasets, to allow data to be presented in maps.

¹⁵ As described in the document *MSFD reporting units* (DIKE_16-2017-03).

¹⁶ There are topological problems (mainly overlaps and gaps) in the GIS data on national marine boundaries submitted by Member States in 2012. Whenever such discrepancies are resolved amongst Member States, MS should upload updated national marine boundary data to the CDR.

¹⁷ [http://eur-lex.europa.eu/legal-content/EN/TXT/HTML/?uri=CELEX:52016DC0478R\(01\)&from=EN](http://eur-lex.europa.eu/legal-content/EN/TXT/HTML/?uri=CELEX:52016DC0478R(01)&from=EN)

shapefiles (see 2012 guidance¹⁸) and using the template available in the MSFD reporting resources page. In that case, Member States are welcome to update the 4geo.xml files if they wish to use different MRUs to those already provided via Eionet or as used in 2012. In order to be able to provide updated drop-down lists of MRU codes in the web-forms, Member States need to provide the updated 4geo.xml files prior to the reporting exercise, so that the MRU codes can be inserted.

3.2 Features and elements assessed

MSFD Annex III (as amended) provides indicative lists of ecosystem elements, anthropogenic pressures and uses and human activities relevant to the marine waters that should be assessed, where relevant; these are further specified as elements in the new GES Decision, where there may be multiple elements per feature (e.g. specific contaminants for D8, specific species within each species group for D1). The information reported for each article has always to be related to a particular feature/element. In [Annex IVb](#), a list of the features is provided¹⁹.

Therefore, for certain features, the specific element covered should be provided (species, habitat, contaminant, marine litter category...), where the name and, where necessary, a code is requested. Also, the source of the code will be requested when a code is provided (to be selected from [Annex IVi](#)). Nevertheless, the preferred sources for codes are the following:

- For species under Descriptors 1, 2 & 3: AphiaID from WoRMS. Additionally, for species under D3 and in the ICES Area, the stock key²⁰ should be provided²¹.
- For habitats under Descriptors 1 & 6: corresponding Broad Habitat Type (also included in Feature_Enum), EUNIS code (2016 if available) or Habitats Directive code.
- For Descriptors 5, 8 & 9: WISE or WISE-B code (see ElementCodeSource enumeration). Additionally, for contaminants in biota (D8) and seafood products (D9), the species should be provided.
- For marine litter under Descriptor 10: category to be selected from MarineLitterCategories_Enum ([Annex IVe](#)).

In any case, lists of Elements, together with their corresponding ElementCode and ElementCodeSource will be made available for the reporting, in order to ensure consistency across the elements reported by Member States.

On the other hand, the GES Decision provides all the criteria to be taken into account for the GES assessments. Within the reporting of the GES assessments, for the different features assessed, an OverallStatus is to be provided at the Descriptor level, as well as the CriteriaStatus for those criteria that have been used in the corresponding assessment. The GEScomponent enumeration ([Annex IVc](#)) includes all the GES components (Descriptors and Criteria) included in the revised Decision (a mapping of the new Decision criteria to the 2010 criteria and indicators is provided in [Annex I](#)); the old criteria and indicators which are not covered by the new Decision have been retained to aid the transition in reporting between the two Decisions.

¹⁸ [2012 MSFD Reporting Guidance](#)

¹⁹ A list of Ecosystem services has also been added, for those MS that use an Ecosystem services assessment under MSFD Article 8(1c).

²⁰ See list at <http://vocab.ices.dk/?ref=357>

²¹ Note that for commercial species assessments, information from the ICES stock assessments will be prefilled for the Atlantic subregions and the Baltic region – see section 5.

3.3 Article 9: GES determination

The schema 'ART9_GES', developed for the reporting of the GES determinations, aims to collect descriptive information at the Descriptor or criterion level, with links to relevant MRUs and features. The threshold and proportion values applicable to the features/elements and contributing to the GES determination are to be provided under the schema 'ART8_GES', together with the achieved values (section 3.4).

The schema includes fields to cover the following topics:

- a. GES component: descriptors or criteria for which the GES determination is provided. The criterion level uses the new GES Decision. Whenever Member States have based their GES determinations on the 2010 Decision, they should link to the equivalent new GES Decision code, based on the mapping to 2010 criteria and indicators provided in [Annex I](#) or to the 2010 criteria and indicators when there is no 2017 criterion equivalent;
- b. Justification for non-use: why it is not appropriate to use a primary criterion for the determination of the GES (GES Decision Art. 3(1));
- c. Justification for delayed GES determinations: why, where relevant, threshold values, lists of criteria elements or methodological standards have not yet been established at Union, regional or subregional level (GES Decision Art. 5(2));
- d. Feature: features to which the GES determination applies. Specific elements of these features (e.g. specified species or contaminants) are to be included in the ART8_GES schema. Features includes the indicative lists provided in the MSFD Annex III;
- e. Description: text description of the (updated) GES determination, which can be linked to the descriptor level and/or criterion level. Specific threshold and proportion values per feature or element are to be included in the ART8_GES schema;
- f. Determination date: the date when the GES determination has been reported;
- g. Update type: whether the GES determination reported in 2018 is as previously reported (i.e. in 2012 or later if updated following the EC Article 12 assessment) (not modified), modified from the previously reported determination or new;
- h. Marine Reporting Unit: area(s) to which the GES determination(s) apply(ies).

A prefilling has been done with the information reported by the Member State in 2012 (or later if updated) and the corresponding XML files have been made available in the MSFD reporting resources page²² for their use by Member State in their reports.

The corresponding diagram and table with guidance for the reporting of the schema elements are in [Annex IIIa](#).

3.4 Article 8(1a, b): assessments against GES

The schema 'ART8_GES' is to be used for reporting on the assessment of current environmental status, and on the pressures and impacts, under Articles 8(1a) and (1b). The schema accommodates the requirements of the new Decision for assessing the extent to which GES has been achieved. This includes the specific elements assessed for the features covered by the GES determination, together with their threshold values (where needed and available) and, where needed as part of the GES determination, the proportion of the assessment area (MRU) over which the threshold values are to be achieved. The rest of the schema accommodates the outputs from the assessment for each Descriptor in relation to the GES determination under Article 9(1).

²² <http://cdr.eionet.europa.eu/help/msfd>

According to the draft *MSFD Article 8 guidance*²³, different levels of integration across criteria and elements, depending on the Descriptor being assessed, are needed to express the extent to which GES has been achieved in accordance with the new Decision. All these levels comprise the parameters and criteria levels, while the descriptor level is addressed differently across the mentioned guidance. The present schema will allow the possibility of reporting the results at the appropriate level of integration. Where integration rules are not yet available at EU or regional level, the Member State can report the national approaches used to determine the extent to which GES has been achieved.

The schema includes fields to cover the following topics:

- a. Marine Reporting Unit: area to which each assessment applies;
- b. Feature: the specific feature(s) (from those specified as being relevant in the GES determination) being assessed. Features includes the indicative lists provided in the MSFD Annex III;
- c. Element: elements of the feature used in the assessment, together with the source of the list (e.g. an EU, regional or nationally-defined list); elements need to be given for species (D1, D2, D3), habitats (D1, D6) and contaminants (D8, D9). For D3, different fish stocks can be reported, whilst for D8 (in biota) and D9 the species used to assess each contaminant can be expressed;
- d. Criteria: criterion for which the thresholds and assessment results are reported;
- e. Parameter: parameter assessed (as used in the related indicator);
- f. Threshold value: where applicable and defined, the value(s) defined for the parameter. If appropriate, a range of values can be reported, as well as a qualitative threshold in cases where a quantitative threshold is not yet available. The source of the threshold value, such as the relevant EU legislation, Regional Sea Convention or national policy process, should be reported;
- g. Value achieved: value(s) resulting from the calculation of the parameter (in the indicator assessment);
- h. Proportion threshold value: the proportion or area over which the threshold value is to be achieved (in order to achieve GES);
- i. Proportion value achieved: the proportion or area over which the threshold values have been achieved in the MRU;
- j. Trend: indicate whether there is improvement or deterioration or the situation is stable compared with the previous 6-year reporting period; the trend is particularly important in cases where a threshold value is not yet available. It is also particularly relevant given that environmental status can be slow to respond to measures and so a trend can give an indication that progress is being made towards GES, even if not yet reached;
- k. Parameter achieved: indicate for the element/criteria/parameter whether the threshold value has been achieved or not over the required proportion of the MRU (depending on the descriptor, there may be further integration of results needed to report overall status);
- l. Related indicator: indicator(s) from which the assessment has been extracted (as reported under the schema 'Indicators');

²³ [GES_17-2017-02_Guidance_MSFDart8_Feb2017TestVersion.pdf](#)

From the results above, the status of each criterion and for each element is reported (for elements integration of criteria is needed for D1 species, D3 species and D6 benthic habitats), as follows:

- a. Criteria status: the status of the criteria as 'Good' OR 'Not good', based on an integration rule applied across the parameters used;
- b. Element status: when applicable (e.g. for species under D1 and D3), indicate the status of the specific element as 'Good' OR 'Not good', based on an integration rule applied across the criteria used;

Finally, from the results of the first (criteria-level) and, where needed second (element-level) steps, the 'Overall status' on the extent to which GES has been achieved per descriptor, where needed, is reported as follows:

- a. GES extent threshold: threshold boundary defined to have achieved GES;
- b. GES extent achieved: indicates to what extent GES has been achieved for the Feature (as a percentage or proportion), including how this is measured (e.g. number of contaminants or species, extent of area);
- c. GES achieved: select from the following options: 'GES achieved', 'GES expected to be achieved by 2020', 'GES expected to be achieved later than 2020, no Article 14 exception reported', 'GES expected to be achieved later than 2020, Article 14 exception reported'²⁴, 'Not assessed', 'Not relevant' or 'Unknown'.
- d. Assessment period: start and end date of the 6-year assessment period, reflecting the latest year for which the assessment is applicable (e.g. whether the assessment covers 2011-2015 data or 2012-2016 data when reported in 2018). Note that a longer time series of data may be used in the assessment (which should be documented in the indicator assessment);
- e. Related pressures: the pressures that are affecting the feature/elements assessed. It is suggested to restrict the number of pressures reported (e.g. up to three) to those considered most preventing GES from being achieved or providing risk that GES cannot be maintained.
- f. Related targets: target(s) defined because GES has not yet been achieved (as reported under the schema 'ART10_Targets');
- g. Integration rules: the type of rule used to integrate the parameters to criterion, the criteria to element or, for D4 and D5, the elements to overall status, and a description of how the rules have been applied (or link to a suitable reference).

Also, text Description fields have been included in each one of the classes, in order to allow comment on the information reported at each level of aggregation (note this field is not intended to duplicate information provided in the indicator assessment, accessible via the 'Related indicator' field). In the case of the Description field at the parameter level, the information on the metric used to get to the value achieved for this parameter is requested.

The resulting values coming from the RSC indicators, as well as the WFD and CFP assessments, have been prefilled whenever available and are available in the MSFD reporting resources page for their use by Member State in their reports.

The corresponding diagram and table with guidance for the reporting of the schema elements are in [Annex IIIb](#). Annex VI includes a list of the GES assessments to be provided per Descriptor.

²⁴ As reported with 2016 Programmes of Measures.

3.5 Article 8(1c): economic and social analysis

The schema 'ART8_ESA' is for reporting on the economic and social analysis of the uses of marine waters and on the costs of degradation, as required under Article 8(1c). The overall report structure and contents follows that used in 2012 reporting, excepting the list of uses and activities is updated to reflect the new MSFD Annex III Table 2b (those marked with an * when relevant to the marine waters of the MS), and there is an updated set of ecosystem service classes.

The schema includes fields to cover the following topics:

- a. Marine Reporting Unit: area to which each assessment applies;
- b. Feature: select the relevant use/activity, ecosystem service or pressure (only in certain cases) to which the assessment applies; for relevant activities, the NACE codes should be provided. Features include the indicative lists in the MSFD Annex III;
- c. Related GES component: for cases where it is relevant, Descriptors or Criterion associated to the assessment (optional field, only to be used for approaches such as the cost-based in the Cost of degradation assessment, when it is done by 'degradation theme').

The economic and social analysis of the use of marine waters is covered by the following fields:

- a. Description: description of the use/activity (e.g. its characteristics in the area reported), of the approach to the economic and social analysis and of the assessment outcomes, including the results of the assessment when the ecosystem services approach is used;
- b. Employment: direct employment (*1000 FTE) under the specific activity in the area assessed;
- c. Production value: production value (€ million) of the specific activity in the area assessed;
- d. Value added: value-added (€ million) by the specific activity in the area assessed;
- e. Related indicator: indicator(s) from which the assessment results have been extracted (indicator codes reported under the schema 'Indicators');
- f. Related pressures: pressure(s) that are caused by the activity; it is suggested to restrict the number of pressures reported (e.g. up to three) to those considered of most relevance to achieving or maintaining GES in the area.
- g. Related ecosystem services: ecosystem service(s) that the activity is dependent on.

The cost of degradation assessment is covered by the following fields:

- a. Approach: to indicate which approach (method) has been used for the calculation of the costs of degradation;
- b. Description: description of main costs or changes due to degradation; details, where relevant, of the importance or value of the theme, or on the benefits derived from it;
- c. Cost of degradation type: selected from a list of types (e.g. preventing costs, mitigation costs);
- d. Results: provide results of the estimated costs (cost-based approach), or a qualitative or quantitative indication of the value of the changes in the ecosystem (ecosystem services approach). Any residual impacts that may be generated should be described here;
- e. Related indicator: indicator(s) from which the assessment results have been extracted (indicator codes reported under the schema 'Indicators').

The corresponding diagram and table with guidance for the reporting of the schema elements are in [Annex IIIc](#).

3.6 Article 10: environmental targets

The schema 'ART10_Targets' collects both general description of the Target, together with other relevant fields, such as the target values to be achieved and the achieved values.

The schema includes fields to cover the following details about each target:

- a. Marine Reporting Unit: area to which each target and its assessment applies;
- b. Target code: code used for the target;
- c. Target description: description/definition of the target;
- d. Timescale: timescale for achievement of the target.
- e. Update date: date when the target has been defined (in 2012, modified following the Article 12 assessment, or in 2018);
- f. Update type: whether the target reported in 2018 is as previously reported (i.e. in 2012 or later if updated following the EC Article 12 assessment) (not modified), modified from the previously reported target, new or no longer required;
- g. GES component: Descriptor or Criteria to which the target applies;
- h. Feature: feature(s) to which the target applies;

For reporting on progress in achieving the target, the following fields are requested:

- a. Related indicator: indicator(s) from which the assessment has been extracted (as reported under the schema 'Indicators');
- b. Element: elements of the feature used in the assessment, together with the source of the list (e.g. an EU, regional or nationally-defined list); elements need to be given for species (D1, D2, D3), habitats (D1, D6) and contaminants (D8, D9). For D3, different fish stocks can be reported, whilst for D8 (in biota) and D9 the species used to assess each contaminant can be expressed;
- c. Parameter: parameter assessed (as used in the related indicator);
- d. Target value: where applicable, value defined for the target;
- e. Value achieved: value(s) resulting from the calculation of the parameter (in the indicator assessment);
- f. Target status: whether the target has been achieved or not;
- g. Assessment period: Start and end date of the assessment;
- h. Description: Description of the assessment outcomes;
- i. Related measures: measure(s) that are used to deliver the target (measure codes reported under the Programmes of Measures reporting).

A prefilling has been done with the information reported in 2012 (or later if updated), and the corresponding XMLs have been made available in the MSFD reporting resources page for their use by Member State in their reports. Regarding the link with the Programmes of Measures (PoM), a prefilling has been done with the measures submitted under the PoM reporting (2015).

The corresponding diagram and table with guidance for the reporting of the schema elements are in [Annex IIIe](#).

3.7 Indicators

This 'indicator' schema is applicable to indicators used for Article 8 assessments (including pressure and socio-economic indicators) and to indicators related to Article 10 targets (to show progress towards achievement of the targets).

As described in section 2.2.2, it is expected that Member States, as well as the RSC, will publish their indicator assessments online. This is the reason why only limited information needs to be captured via XML.

The schema includes fields to cover the following topics:

- a. Indicator code: to be submitted as the Unique identifier for the indicator;
- b. Indicator title: as used in the Common indicator structure (see [Annex V](#));
- c. Related GES component: Descriptor or Criteria to which the indicator applies (whenever the indicator is a socio-economic indicator, or if it is linked to a target that is not related to a specific GES component, it should be marked as 'Not Relevant');
- d. Feature: feature(s) that has been assessed (it can be an Ecosystem component, Pressure, Use/Activity or Ecosystem service);
- e. Indicator source: whether it is a national indicator, from a Regional Sea Convention, from the CFP or from the WFD;
- f. Indicator unique reference: URL or DOI (Digital Object Identifier) where the whole indicator assessment can be accessed. The publication online is expected to follow the Common Indicator Structure²⁵, where all details regarding methodology and assessment results are included;
- g. Related environmental target: target(s) for which the indicator can show progress (where the indicator is applicable to Article 10);
- h. Marine Reporting Unit: area(s) to which the assessment(s) apply(ies);

And the following fields are requested for the underpinning datasets:

- a. URL: URL or DOI for the data from the relevant monitoring programme and the dataset underpinning the indicator assessment (or web service);
- b. MD URL: Unique resource locator for the metadata (or web service).

A QC routine will check if the links are valid and the dataset or service and corresponding metadata are accessible.

The information on the RSC indicators, as well as the CFP assessments, has been prefilled whenever available, and the corresponding XML files have been made available in the MSFD reporting resources page for their use by Member State in their reports.

The corresponding diagram and table with guidance for the reporting of the schema elements are in [Annex III d](#).

3.8 Metadata of the reporter

Within all the schemas, the reporter information, containing the fields of Table 6, is to be reported.

²⁵ MSFD Guidance Document 13

Table 6 Fields on metadata of the reporter

Class	Schema element	Description	Property	Guidance
ReporterInfo	CountryCode	Country reporting	Required. Two-letter ISO country code.	Enter corresponding country code from CountryCode_Enum
ReporterInfo	ContactName	Name of the reporter	Optional	Free text (max. 100 characters)
ReporterInfo	ContactMail	Email of the reporter or functional email of the organisation	Required	Enter corresponding eMail (max. 50 characters)
ReporterInfo	ContactOrganisation	Name of the reporter's organisation and address	Required	(max. 1000 characters)
ReporterInfo	ReportingDate	Date when the reporting has been done	Required	YYYY-MM-DD

4 Quality Control specifications

Quality control (QC) specifications have been developed to ensure that the XML files submitted by Member States are as required in the schema specifications and the guidance. Among these, there are:

- Element checks: they will check whether all the elements provided in the file have the required content/format.
- Within-schema checks: they will check all the dependencies among elements within each of the schemas.
- Cross-schema checks: they will check all the dependencies among the schemas reported.

Feedback will be provided to MS through *errors*, *warnings* and *blockers*, so that they can be aware of errors and amend the submitted files when the envelope is released in ReportNet. The QAs can also be run in CDR to the files before releasing the envelope, so that the Member State can ensure the delivery of files without errors.

The QC specifications are part of the reporting package and can be accessed through the EEA ReportNet resource page. When ready, the QC checks can be done in the CDR Sandbox (<http://converters.eionet.europa.eu/do/qaSandboxForm>), or the source code can be downloaded from EEA's repository (<https://svn.eionet.europa.eu/repositories/Reportnet/Dataflows>).

5 Links to other policy processes (WFD, CFP, RSC)

The information coming from the most recent WFD, CFP and RSC assessments has been prefilled, whenever their use is required by the GES Decision (WFD, CFP), or where relevant (RSCs), according to the schemas and schema elements where it matches. This prefilling is offered as an option from which Member States will be able to select for their reporting those aspects that they wish to reuse from these sources and submit as part of their 2018 MSFD report. The MS will have the option to use, modify or not use the information prefilled from these other sources.

For WFD, the status classification of the coastal water bodies (and territorial waters in the case of the chemical status) reported at the Quality Element level has been used to populate relevant fields for some criteria/elements (D5 and D8), using the schema 'ART8_GES'.

For CFP, the assessed information relating to criteria D3C1 (fishing mortality rates) and D3C2 (spawning stock biomass) per fish stock, together with the target levels required under CFP, are provided from the latest ICES assessments. For these stocks, the unique stock assessment key provided via the ICES Stock assessment database has been used, where the relevant assessment information (SSB, F) are contained (see example²⁶).

The regional indicators information from HELCOM and OSPAR has been prefilled for the schema 'Indicators' and from HELCOM for the schema 'ART8_GES'.

6 Reporting process: steps

The reporting process for preparing the XML files comprises the following steps. These files are generated automatically by completing the web-forms or can be generated directly from Member State databases:

Step 1. As a preliminary step, MS are requested to submit to CDR updated 4geo.xml files (when necessary) by 30 May 2018, in order to generate the MRU codes/names. This will allow the codes to be inserted into the reporting tools (web-forms and Access database).

Step 2. Once the reporting exercise starts (July 2018) MS should first complete 'ART9_GES' schema, with a general description of the determination of GES at the descriptor and/or criterion level.

Step 3. MS should then complete the 'Indicators' schema, to provide the basic information for all the assessments that have been performed. This generates the indicator codes for use in the other schemas (ART8_GES, ART8_ESA, ART10_Targets).

Step 4. Then the 'ART10_Targets' schema should be addressed, with a general description of Targets, links to associated indicators and information on progress made. This will also generate the set of target codes to be referred to in the ART8_GES schema.

Step 5. The third schema to be completed is 'ART8_GES', which includes the elements, threshold and proportion values that are the specific parts of the Article 9 GES determination but intrinsically linked to the Article 8 assessment, as well as the link to the indicators that have been used within the different assessments (from step 3) and the targets (from step 4).

Step 6. Finally, the schema of 'ART8_ESA' should be completed.

Step 7. Create an envelope in the corresponding country folder in ReportNet (folders related to the "MSFD - Articles 8, 9 and 10 - XML data" reporting obligation²⁷) and upload the XML files. Run the corresponding QAs to ensure a delivery without errors. Submit the XML files by releasing the envelope, which will generate a 'receipt' (see section 7.3).

7 Procedures and format for reporting

This section outlines the mechanisms for preparing the reporting information, its formats and the transmission procedure as part of the formal requirement to notify the Commission.

7.1 Technical support for reporting

For details on the technical preparation of the reports, including use of the on-line web-form application for reporting and preparation of xml schemas, as well as the applicable quality control rules, please refer to the EEA ReportNet resource page:

²⁶ <http://standardgraphs.ices.dk/ViewCharts.aspx?key=8114>

²⁷ <http://rod.eionet.europa.eu/obligations/759>

<http://cdr.eionet.europa.eu/help/msfd>.

During the reporting process, an **MSFD Helpdesk** (msfd.helpdesk@eionet.europa.eu) will be in operation to support both content and technical queries which may arise.

Note that only nominated reporters are able to report. The list of reporters is available in the following link: http://www.eionet.europa.eu/ldap-roles/?role_id=extranet-msfdreporter-data. A Member State (members from WG DIKE or the MSCG) may change one or more of its nominated reporters by contacting the MSFD Helpdesk.

7.2 Reporting language

Member States have the right to complete the reporting sheets in any official EU language.

However, reporting in English is strongly encouraged by the EC for the following reasons:

- a. The information reported will be needed to support and enhance ongoing cooperation amongst MS within a region or subregion (when the information is made accessible via WISE-Marine, for example); use of a common language will facilitate such cooperation.
- b. The translation of a MS's information into a common language will support its further use in aggregation of the information to regional, European and global scales for ongoing State of the Environment reporting.
- c. The Commission has 6 months in which to undertake its Article 12 assessment. It will greatly assist this process if the information is available in a common language. This short time period means it is not feasible to have the information formally translated; consequently, translation by the MS itself prior to submission will help avoid misinterpretation of the information reported.

Some Member States may not want to take the responsibility to submit the content of the reporting sheet in English, as there is a risk of misinterpretation due to the translation between the adopted version (in national language) and what would be considered as the "official reported information" by the Commission that will be used for the article 12 assessment. On the other hand, translation by the Commission Services in order to undertake its Article 12 assessment is also subject to possible risks of misinterpretation of what was reported by the Member State.

7.3 Formal notification

Formal notification of the Member State's report(s) should follow the standard practice, as follows:

The Member State's Permanent Representation to the European Commission should send to the Commission²⁸ a) a suitable cover letter indicating the relevant Directive and articles to which the notification refers and b) the receipt(s) obtained from ReportNet of all the reports (files) that have been deposited in relation to this notification.

The cover letter and ReportNet receipt(s) can be sent in hard copy or electronically (as pdf).

The reports deposited in ReportNet as part of the notification should be:

- a. Validated XML files for the following schemas: 'ART9_GES', 'ART8_GES', 'ART8_ESA', 'ART10_Targets' and 'Indicators'. Each file should hold the data and information defined in the schemas, including URL links to the relevant publicly and permanently available indicator assessments and associated data sets;

²⁸ Unit ENV.C.2 "Marine Environment and Water Industry" mail: ENV-MARINE-ENVIRONMENT@ec.europa.eu

- b. Text-based report(s) as described in section 2.2.4 and Table 2, if considered necessary. Where the structure of the report differs to that in Table 2, a correlation table showing where the sections in Table 2 can be found (pages, section number) should be provided;
- c. In cases where the indicator assessments under point (a) are not available online, these should be submitted in pdf format (for example, as annexes to the report under point (b));
- d. In cases where the Marine Reporting Units used are defined by the Member State (i.e. additional to those prepared by the EEA/ETC-ICM), an updated '4geo.xml' file, together with associated GIS shapefiles²⁹, should be provided.

Each Member State has the right to submit any further information it considers appropriate as part of its formal notification. This could, for example, include joint documentation ('roof report') prepared via a Regional Sea Convention or summary documentation used for the Article 19(2) public consultation (where this differs to the text-based report under point (b) above).

²⁹ See section 3.1; these should be submitted before the rest of the reports in order to have the MRU codes available to populate the other schemas.

ANNEX I: Relationship between Decision (EU) 2017/848 criteria and the criteria and indicators in Decision 2010/477/EU

P-I-S: Pressure, Impact or State criterion

Criteria	P-I-S	Primary criteria (bold), Secondary criteria	2010/477/EU Criteria or Indicators codes
D2C1	Pressure	D2C1 Newly-introduced NIS	–
D2C2	Pressure	D2C2 Established NIS	2.1, 2.1.1
D2C3	Impact	D2C3 Adverse effects of NIS on species and habitats	2.2, 2.2.1, 2.2.2
D3C1	Impact	D3C1 Fishing mortality rate (F)	3.1, 3.1.1, 3.1.2
D3C2	State	D3C2 Spawning stock biomass (SSB)	3.2, 3.2.1, 3.2.2
D3C3	State	D3C3 Population age and size distribution	3.3, 3.3.1, 3.3.3, 3.3.4
D5C1	Pressure	D5C1 Nutrient concentrations	5.1, 5.1.1
D5C2	Impact	D5C2 Chlorophyll a concentration	5.2.1
D5C3	Impact	D5C3 Harmful algal blooms	5.2.4
D5C4	Impact	D5C4 Photic limit	5.2.2
D5C5	Impact	D5C5 Dissolved oxygen concentration	5.3.2
D5C6	Impact	D5C6 Opportunistic macroalgae of benthic habitats	5.2.3
D5C7	Impact	D5C7 Macrophyte communities of benthic habitats	5.3.1
D5C8	Impact	D5C8 Macrofaunal communities of benthic habitats	–
D6C1	Pressure	D6C1 Physical loss of the seabed	6.1 in part
D6C2	Pressure	D6C2 Physical disturbance to the seabed	6.1 in part
D6C3	Impact	D6C3 Adverse effects from physical disturbance on benthic habitats	6.1.2
D7C1	Pressure	D7C1 Permanent alteration of hydrographical conditions	7.1, 7.1.1
D7C2	Impact	D7C2 Adverse effects from permanent alteration of hydrographical conditions on benthic habitats	7.2, 7.2.1, 7.2.2
D8C1	Pressure	D8C1 Contaminants in environment	8.1, 8.1.1
D8C2	Impact	D8C2 Adverse effects of contaminants on species and habitats	8.2 in part, 8.2.1
D8C3	Pressure	D8C3 Significant acute pollution events	8.2.2 (pressure aspect)
D8C4	Impact	D8C4 Adverse effects of significant pollution events on species and habitats	8.2 in part, 8.2.2 (impact aspect)
D9C1	Pressure	D9C1 Contaminants in seafood	9.1, 9.1.1
D10C1	Pressure	D10C1 Litter	10.1 in part, 10.1.1, 10.1.2
D10C2	Pressure	D10C2 Micro-litter	10.1 in part, 10.1.3
D10C3	Pressure	D10C3 Litter ingested	10.1 in part, 10.2.1
D10C4	Impact	D10C4 Adverse effects of litter on species	10,2
D11C1	Pressure	D11C1 Anthropogenic impulsive sound	11.1, 11.1.1
D11C2	Pressure	D11C2 Anthropogenic continuous low-frequency sound	11.2, 11.2.1
D1C1	Impact	D1C1 Mortality rate from incidental by-catch	–

Criteria	P-I-S	Primary criteria (bold), Secondary criteria	2010/477/EU Criteria or Indicators codes
D1C2	State	D1C2 Population abundance	1.2, 1.2.1
D1C3	State	D1C3 Population demographic characteristics (Mammals, turtles, commercial fish & cephalopods, HD fish) (Birds, non-commercial fish & cephalopods)	1.3, 1.3.1
D1C4	State	D1C4 Population distributional range and pattern (Mammals, turtles, HD fish) (Birds, non-HD fish, cephalopods)	1.1, 1.1.1, 1.1.2
D1C5	State	D1C5 Habitat for the species (Mammals, turtles, HD fish) (Birds, non-HD fish, cephalopods)	Supporting habitat for species in D1 chapeau text but not specifically included as an indicator
D1C6	State	D1C6 Pelagic habitat condition	1.6 in part, 1.6.1 in part, 1.6.2 in part, 1.6.3 in part
D6C4	State	D6C4 Benthic habitat extent	1.5, 1.5.1, 6.1.1
D6C5	State	D6C5 Benthic habitat condition	1.6 in part, 1.6.1 in part, 1.6.2 in part, 1.6.3 in part, 6.2, 6.2.1, 6.2.2, 6.2.3, 6.2.4
D4C1	State	D4C1 Trophic guild species diversity	1.7 in part, 1.7.1 in part
D4C2	State	D4C2 Abundance across trophic guilds	1.7 in part, 1.7.1 in part, 4.3, 4.3.1
D4C3	State	D4C3 Trophic guild size distribution	4.2, 4.2.1
D4C4	State	D4C4 Trophic guild productivity	4.1, 4.1.1
		Not included in 2017 Decision	1.1.3
		Not included in 2017 Decision	1.3.2
		Not included in 2017 Decision	1,4
		Not included in 2017 Decision	1.4.1
		Not included in 2017 Decision	1.4.2
		Not included in 2017 Decision	1.5.2
		Not included in 2017 Decision	3.3.2
		Not included in 2017 Decision	5.1.2
		Not included in 2017 Decision	5,2
		Not included in 2017 Decision	5,3
		Not included in 2017 Decision	9.1.2

ANNEX II: Illustrative examples of Article 9 and Article 8 (1a, b) reporting outputs

Worked examples are presented in the embedded spreadsheet:

- a. The examples demonstrate how the requirements of the GES Decision can be expressed in the XML schemas, and aim to cover a variety of possible scenarios for reporting (e.g. use of regional or national information, use of primary and/or secondary criteria, various different outcomes from the assessments).
- b. Example information for every criterion is provided, using information which is as realistic as possible (taken in many cases from existing assessments), but is provided for illustrative purposes only.
- c. Cells where no information is needed for a particular descriptor are greyed out (dark grey – not needed, light grey not needed depending on previous entries, e.g. if Parameter is entered, ParameterOther is not needed).
- d. The examples cannot cover all possible reporting needs of Member States, but provide further testing of the schemas and demonstrate their flexibility to cover all the Descriptors and multiple ways in which Member States can report their information. Further, some information is still under development (e.g. threshold values at regional and EU levels) and national alternatives may not be available.



MSFD2018reporting_
art8-9-10_WorkedEx:

ANNEX III: Schemas

a) ART9_GES

According to what has been described in section 3.3, Figure 2 represents the structure of the schema.

Figure 2 XSD diagram of 'ART9_GES'

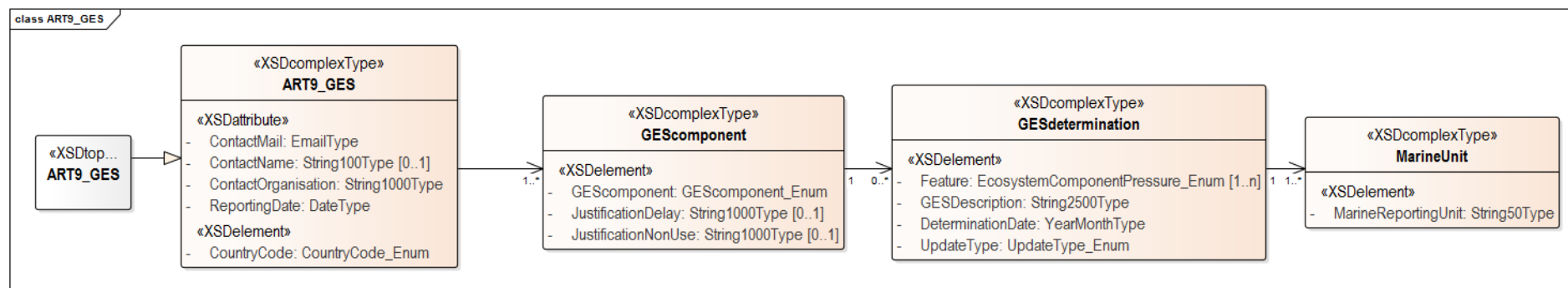

Based on the schema, Table 7 provides the details of the schema fields.

Table 7 Fields of the schema 'ART9_GES'

Schema class	Schema field	Description	Property	Guidance
MarineUnit	MarineReportingUnit	Area(s) where the GES determination(s) applies	Required	Enter all relevant MRUs from List: Marine Reporting Units (MarineUnitID) as reported by MS in 4geo.xml file, or select one from the Marine Reporting Units list. In cases where all GES determinations apply to all of the Member State's marine waters, enter all relevant MRUs here. In cases where the GES determination for a particular Descriptor differs between different parts of MS marine waters (such as in different subregions), enter a separate list of MRUs and associated GES determinations for those parts.
GEScomponent	GEScomponent	Descriptor or criteria for which the GES determination is provided, or a justification for non-	Required	Enter corresponding 'Descriptor' OR 'Criteria' code from List: GEScomponent_Enum.

Schema class	Schema field	Description	Property	Guidance
		use (primary criterion) is provided		
GEScomponent	JustificationNonUse	Justification for why it is not considered appropriate to use a primary criterion for determination of GES, which MS were informed, how and when (GES Decision Art 3(1))	Conditional: required for primary criteria that have not been used for determination of the GES	Free text (max. 1000 characters).
GEScomponent	JustificationDelay	Justification, where relevant, for why threshold values, lists of criteria elements or methodological standards have not yet been established at Union, regional or subregional level (GES Decision Art. 5(2)). Explanation for cases where these are available but are not used.	Conditional: required where relevant	Free text (max. 1000 characters). Where threshold values are not yet established at Union, regional or subregional level (where required by Decision (EU) 2017/848), provide a justification under the relevant criterion. Where lists of criteria elements or methodological standards are not yet established at Union, regional or subregional level (where required by Decision (EU) 2017/848), provide a justification under the relevant Descriptor. In cases where this information is available from other policies/mechanisms but not used, a justification should be provided.
GESdetermination	Feature	Feature(s) to which the GES determination applies	Required (when a GESDescription is provided)	Enter the codes of the Features for which the GES determination applies from List: Feature_Enum.
GESdetermination	GESDescription	Description of the GES determination, based on either the MSFD Annex I descriptor text (when defined at Descriptor level) or the criterion text in Decision (EU) 2017/848 (when defined at criterion	Required (when a justification for non use of a primary criterion is not provided)	Free text (max. 2500 characters).

Schema class	Schema field	Description	Property	Guidance
		level).		
GESdetermination	DeterminationDate	Date when this GES determination is reported	Required (when a Description is provided)	YYYYMM
GESdetermination	UpdateType	Indicate whether the GES determination reported is as reported previously (e.g. in 2012), modified or new	Required (when a GESDescription is provided)	Enter: 'Same as last reported determination', 'Modified from reported determination' OR 'New determination', compared with previous (2012 or later) reporting of Article 9(1) (some determinations were updated due to the 2014 Article 12 assessment).

b) ART8_GES

According to what has been described in section 3.4, Figure 3 represents the structure of the schema.

Figure 3 XSD diagram of 'ART8_GES'

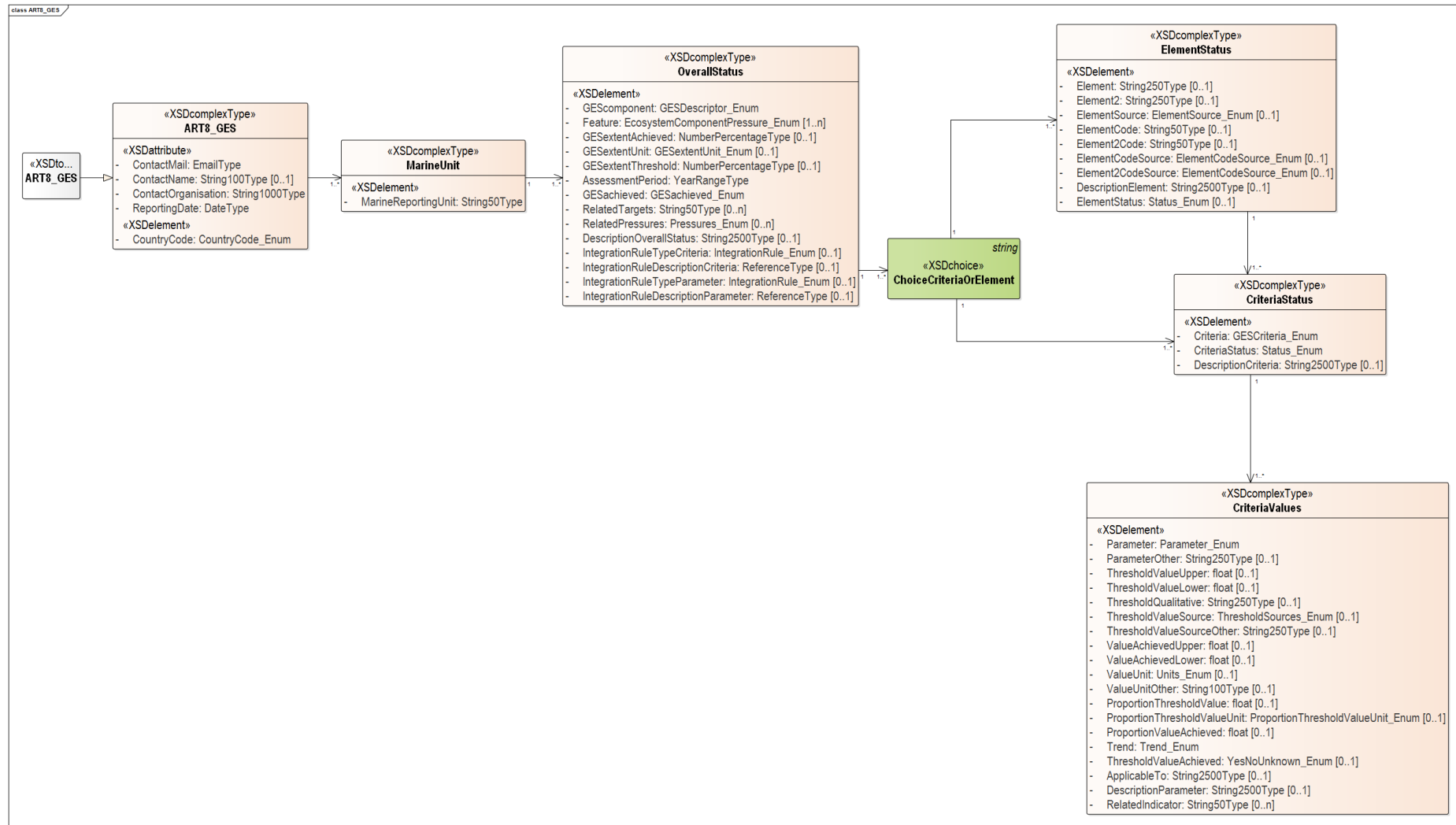

Based on the schema, Table 8 provides the details of the schema fields.

Table 8 Fields of the schema 'ART8_GES'

Schema class	Schema field	Description	Property	Guidance
MarineUnit	MarineReportingUnit	Area where the assessment applies and the 'extent to which GES has been achieved' is reported for the descriptor.	Required	Enter one from List: Marine Reporting Unit (MarineUnitID) as reported by MS in 4geo.xml file, or select one from the Marine Reporting Units list.
OverallStatus	GEScomponent	Descriptor for which the assessment is reported	Required	Enter corresponding 'Descriptor' code from List: GEScomponent_Enum.
OverallStatus	Feature	Feature(s) to which the assessment applies	Required	Enter the codes of the Features that have been assessed from List: Feature_Enum, that are relevant for this Descriptor and MRU. These should be included in the related GES determination (Art9_GES).
OverallStatus	GESextentThreshold	Threshold defined for achievement of GES	Required (when GESextentAchieved is reported)	Percentage OR number (Number applicable only for D2)
OverallStatus	GESextentAchieved	Indicate, where relevant, to what extent GES has been achieved for a Feature	Required (where applicable)	Percentage OR number (Number applicable only for D2)
OverallStatus	GESextentUnit	Indicate the unit for GES extent	Required (when GESextentAchieved is reported)	Enter: 'Proportion of species in good status within species group', 'Proportion of area in good status', 'Proportion of populations in good status', 'Proportion of habitats in good status', 'Proportion of substances in good status', 'Proportion of litter categories in good status', 'Number of newly-introduced species' OR 'Not relevant'.
OverallStatus	GESachieved	Indicate whether GES has been achieved or not	Required	Enter 'GES achieved', 'GES expected to be achieved by 2020', 'GES expected to be achieved later than 2020, no Article 14 exception reported', 'GES expected to be achieved later than 2020, Article 14 exception reported', 'Not assessed', 'Not relevant' OR 'Unknown'.

Schema class	Schema field	Description	Property	Guidance
OverallStatus	DescriptionOverallStatus	Description of or comment on the Overall Status assessment.	Optional	Free text (max. 2500 characters). Whenever a schema prefilled with EU (WFD, CFP) or regional (RSC) information has been modified or not used, provide reasons here.
OverallStatus	AssessmentPeriod	Start and end date for the 6-year assessment period	Required	YYYY-YYYY
OverallStatus	RelatedPressures	Pressures that are or may have an impact on the feature assessed	Required	Enter as many 'Pressures' codes as necessary (as in Feature_Enum list 'Anthropogenic pressures on the marine environment (Table 2a)', NOT from list 'Pressure levels and impacts in marine environment') whenever they are considered relevant (e.g. provide the top three pressures). In the case where there is no clear pressure relationships, enter 'Unknown'.
OverallStatus	RelatedTargets	Target(s) defined under Article 10 which are relevant for the feature being assessed (i.e. addressing relevant pressures and impacts)	Required	Enter as many target codes (as reported in the schema ART10_Targets.xml) as are relevant OR 'No targets'.
OverallStatus	IntegrationRuleTypeCriteria	Integration rule type applied when more than one criterion is used to assess the element.	Required (when more than one criterion has been used per element)	Enter code from List: IntegrationRule_Enum. Enter 'Not relevant' in cases where there is only one criterion used per element. Use also for D4 and D5 for the integration of elements to define overall status for a D4 ecosystem or for D5).
OverallStatus	IntegrationRuleDescriptionCriteria	Description of how the rule has been applied	Required (where applicable)	Free text (max. 1000 characters) or provide URL or attach file (to be uploaded to the same folder as the XML).
OverallStatus	IntegrationRuleTypeParameter	Integration rule type applied when more than one parameter is used to assess the criterion.	Required (when more than one parameter has been used per criterion)	Enter code from List: IntegrationRule_Enum. Enter 'Not relevant' in cases where there is only one parameter used per criterion.
OverallStatus	IntegrationRuleDescriptionParameter	Description of the rule applied	Required (where applicable)	Free text (max. 1000 characters) or provide URL or attach file (to be uploaded to the same folder as the XML).
ElementStatus	Element	Specific element of the Feature which is assessed	Required (where applicable)	Enter the name of the species (D1, D2, D3, D5, D8, D10), habitat (D1, D2, D6, D7, D8), ecosystem/trophic guild (D4), nutrient/contaminant

Schema class	Schema field	Description	Property	Guidance
		(species, habitat, contaminant...)	applicable)	(D5, D8, D9) litter category (D10) or other type of element (D5, D6, D7, D8, D11) (max. 250 characters).
ElementStatus	ElementCode	Code of Element	Conditional (when Element is provided)	Enter the corresponding code or ID, as described in Reporting Guidance section 3.2 (max. 50 characters).
ElementStatus	ElementCodeSource	Source of ElementCode	Conditional (when the ElementCode is provided)	Enter code from List: ElementCodeSource_Enum. When 'Other' is selected, provide details in field 'DescriptionElement'.
ElementStatus	Element2	Associated element of the feature that is assessed	Conditional: when GEScomponent is 'D3' (stocks), 'D9' (species), 'D10' (species affected) OR 'D11' (time period)	Enter the name of the stock for the commercial species assessed (D3), the species of seafood used to assess the contaminant level (D9), the species used for litter ingestion assessment (D10C3) and the time period used for acute noise events (D11C1) (max. 250 characters).
ElementStatus	Element2Code	Code of Element2	Conditional (when Element2 is provided)	Enter the corresponding code or ID, as described in Reporting Guidance section 3.2 (max. 50 characters).
ElementStatus	Element2CodeSource	Source of ElementCode2	Conditional (when the ElementCode2 is provided)	Enter code from List: ElementCodeSource_Enum. When 'Other' is selected, provide details in field 'DescriptionElement'.
ElementStatus	ElementSource	Source of the agreed list of elements used in the assessment	Conditional (when the Element is provided)	Enter: 'EU', 'HELCOM', 'OSPAR', 'BARCON', 'BSC', 'MS in (sub)region', 'ICES', 'CFP', 'National', OR 'Other'. When 'Other' is selected, provide details of this in field 'DescriptionElement'.
ElementStatus	DescriptionElement	Description of the element assessment outcomes, when needed	Optional	Free text (max. 2500 characters). Free text (max. 2500 characters); provide details here if 'Other' is selected for 'ElementCodeSource', 'Element2CodeSource' or 'ElementSource', when 'Directional trends' and 'Pressure-based proxy' has been used and when ElementStatus or CriteriaStatus is 'Good, based on low-risk'.
ElementStatus	ElementStatus	Indicate the status of the specific element (species, habitat, contaminant) based on the outcomes of the criterion used	Required (where applicable)	Enter: 'Good', 'Good, based on low risk', 'Not good', 'Contributes to assessment of another criterion/element', 'Not assessed' OR 'Unknown'. If 'Good, based on low risk' is selected, provide a justification in 'DescriptionElement'.

Schema class	Schema field	Description	Property	Guidance
CriteriaStatus	Criteria	Criterion for which the assessment is reported	Required	Enter corresponding 'Criteria' code from List: GEScomponent_Enum.
CriteriaStatus	CriteriaStatus	Indicate the status of the criteria based on the outcomes of the parameters used	Required (where applicable)	Enter: 'Good', 'Good, based on low risk', 'Not good', 'Unknown' OR 'Not assessed'. If 'Good, based on low risk' is selected, provide a justification in 'DescriptionElement'.
CriteriaStatus	DescriptionCriteria	Description of the criteria assessment outcomes, when needed	Optional	Free text (max. 2500 characters).
CriteriaValues	Parameter	Parameter assessed	Required	Enter code from List: Parameters_Enum. If 'Other' is selected, provide details in field 'ParameterOther'.
CriteriaValues	ParameterOther	Parameter assessed	Conditional (if Parameter is 'Other')	Free text (max. 250 characters).
CriteriaValues	ThresholdValueUpper	Value defined as threshold. Whenever the threshold has been defined as a range: upper value.	Conditional: required if a value is provided under ThresholdValueLower.	Number
CriteriaValues	ThresholdValueLower	Whenever the threshold has been defined as a range: lower value.	Optional (where available)	Number (for use when the value to be achieved should be between the upper and lower threshold values entered).
CriteriaValues	ThresholdQualitative	Definition of the threshold if ever it is not quantitative	Optional (where available)	Free text (max. 250 characters).
CriteriaValues	ThresholdValueSource	Provide the source of the threshold value, e.g. taken from other legislation or policies, or defined through regional processes or nationally	Conditional (when ThresholdValueUpper is provided)	Enter one code from List: ThresholdSources_Enum. When 'Other' is selected, provide details in field 'ThresholdValueSourceOther'. When 'Directional trends' or 'Pressure-based proxy' is selected, indicate if this is national or (sub)regionally agreed under 'ThresholdValueSourceOther'.

Schema class	Schema field	Description	Property	Guidance
CriteriaValues	ThresholdValueSourceOther	Whenever the threshold value has been taken from the application of other legislation or policies, source	Conditional (if ThresholdValueSource is 'Other')	Free text (max. 250 characters).
CriteriaValues	ValueAchievedUpper	Value resulting from monitoring and assessment. Whenever the value has to be provided as a range: upper value.	Conditional: required if a value is provided under ValueAchievedLower.	Number. For multiple samples/sites in the MRU, provide the upper (this field) and lower (next field) values in the dataset. The proportion of values achieving the threshold value should be expressed in 'ProportionValueAchieved'.
CriteriaValues	ValueAchievedLower	Whenever the value has to be provided as a range: lower value.	Optional (where available).	Number
CriteriaValues	ValueUnit	Unit in which the value is expressed	Conditional: required when ValueAchievedLower is provided	Enter code from List: Units_Enum. When 'Other' is selected, provide details in field 'ValueUnitOther'.
CriteriaValues	ValueUnitOther	Unit in which the value is expressed	Conditional (if ValueUnit is 'Other')	Free text (max. 20 characters)
CriteriaValues	ProportionThresholdValue	Proportion of MRU area over which the threshold value set is to be achieved	Conditional (where relevant)	Number
CriteriaValues	ProportionValueAchieved	Proportion of MRU area, or of the species group or habitat type within the MRU, over which the threshold value set has been achieved, OR extent of adverse effect (not achieving threshold values)	Optional (where available)	Number

Schema class	Schema field	Description	Property	Guidance
CriteriaValues	ProportionThresholdValueUnit	Unit for proportion/extent	Conditional: required when ProportionThresholdValue is provided	Select one from list: '% area of MRU achieving threshold value' '% of population achieving threshold value' '% of samples achieving threshold value' '% area of habitat achieving threshold value' '% of species group adversely affected' 'extent in km2 of MRU adversely affected' 'extent in km2 of habitat adversely affected' 'extent in km2 of pressure'. 'Adversely affected' indicates values are below the threshold value.
CriteriaValues	Trend	Trend in status compared with previous 6-year reporting period	Required	Enter: 'Improving' (status improving, pressure or impact reducing), 'Stable', 'Deteriorating' (status deteriorating, pressure or impact increasing), 'NotRelevant', 'Unknown'.
CriteriaValues	ParameterAchieved	Indicate whether the threshold value has been achieved or not (over the required proportion of the assessment area)	Required	Enter: 'Yes' OR 'No', based on Threshold value AND, where appropriate, proportion value, OR 'Unknown', 'Not assessed' or 'Yes, based on low risk'.
CriteriaValues	DescriptionParameter	Description of the parameter assessment outcomes, when needed	Optional	Free text (max. 2500 characters). Describe here the metric that has been used to get the ValueAchieved (e.g. annual average; winter average; percentile 90; etc.)
CriteriaValues	RelatedIndicator	Indicator/s from which the assessment has been extracted	Required (where available)	Enter as many indicator codes as necessary (as reported by MS under the schema 'Indicators').

c) ART8_ESA

According to what has been described in section 3.5, Figure 4 represents the structure of the schema.

Figure 4 XSD diagram of 'ART8_ESA'

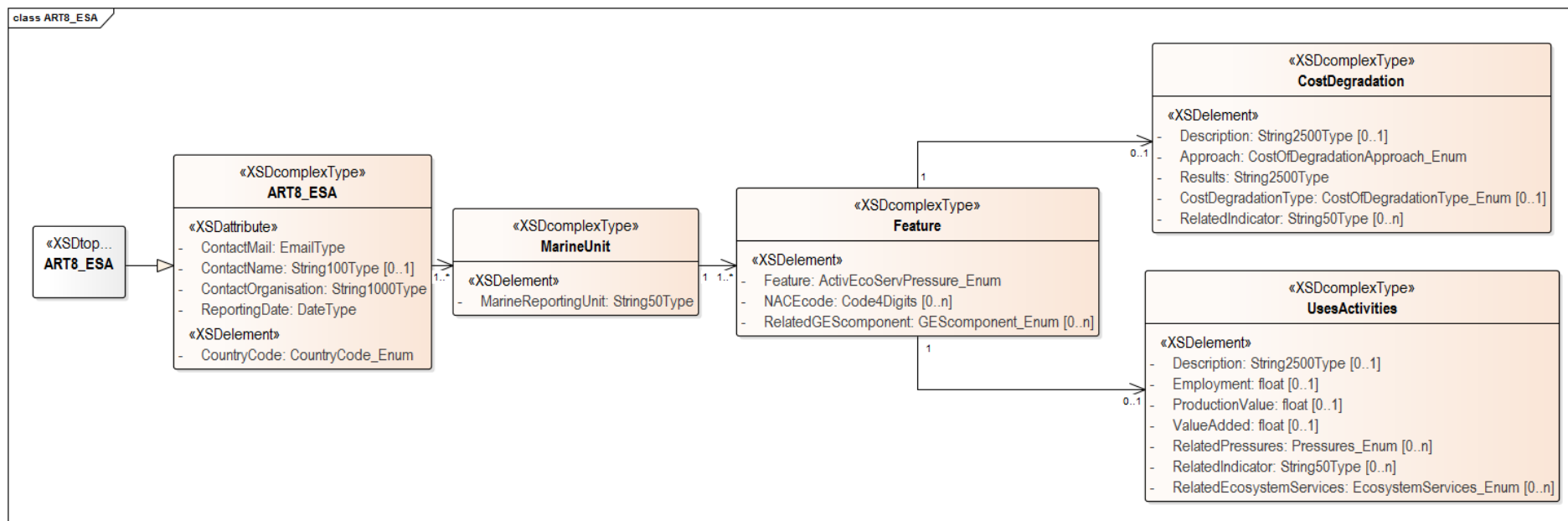

Based on the schema, Table 9 provides the details of the schema fields.

Table 9 Fields of the schema 'ART8_ESA'

Schema class	Schema field	Description	Property	Guidance
MarineUnit	MarineReportingUnit	Area where the Assessment applies	Required	Enter Marine Reporting Unit code (MarineUnitID as reported by MS in 4geo.xml file, or select from the Marine reporting units list).
Feature	Feature	Feature to which the assessment applies	Required	Enter corresponding 'Use/Activity', 'Ecosystem Service', or 'Pressure' code from List: Feature_Enum. Pressure codes would be expected when the cost-based approach is done by 'degradation theme', instead of by 'human activity' (in the cost of degradation

Schema class	Schema field	Description	Property	Guidance
				assessment).
Feature	NACEcode	Enter the NACE codes relevant to the Use/activity (from which the socio-economic data are derived)	Required (where applicable)	Enter the relevant NACE codes from List: NACECodes_Enum. If the sector is not in the list, enter the corresponding NACE 4-digit code.
Feature	RelatedGEScomponent	Descriptors or criterion to which the assessment is related	Optional	Enter as many Descriptors or Criterion codes as necessary from List: GEScomponent_Enum.
UsesActivities	Description	Description of the use/activity (e.g. its characteristics in the area reported), of the approach to the analysis and of the assessment outcomes, including the results of the assessment when the ecosystem services approach is used	Optional	Free text (max. 2500 characters).
UsesActivities	Employment	Direct employment (*1000 FTE) under the activity	Optional	Number
UsesActivities	ProductionValue	Production value (€ million) of the activity	Optional	Number
UsesActivities	ValueAdded	Value-added (€ million) by the activity	Optional	Number
UsesActivities	RelatedPressures	Pressures that are produced by the activity	Required (where applicable)	Enter as many 'Pressures' codes (from Feature_Enum list 'Anthropogenic pressures on the marine environment(Table 2a)', NOT from list 'Pressure levels and impacts in marine environment') as necessary (suggest up to three pressures) In the case where there is no clear pressure relationships, enter 'Unknown'.

Schema class	Schema field	Description	Property	Guidance
UsesActivities	RelatedIndicator	Indicators used for the assessment	Required (where applicable)	Enter as many indicator codes as necessary (as reported under the schema 'Indicators').
UsesActivities	RelatedEcosystemServices	Ecosystem services that the activity is dependent on	Optional	Enter as many 'EcosystemServices' codes as necessary (from Feature_Enum).
CostDegradation	Description	Describe main costs or changes due to degradation and, where relevant, provide details on the importance or value of the theme, or on the benefits derived from it, and details on what aspects have been included.	Optional	Free text (max. 2500 characters).
CostDegradation	Approach	Indicate which approach has been used for the calculation of the cost of degradation	Required	Enter 'Cost-based', 'Ecosystem services', 'Thematic' OR 'Other' (to be explained in the field Description).
CostDegradation	CostDegradationType	Cost of degradation type	Optional	Enter 'monitoring and information costs', 'preventing and avoidance costs', 'enhancement costs', 'transaction costs', 'opportunity costs', 'mitigation costs' OR 'residual impacts, with reference to the current legislation objectives'.
CostDegradation	Results	Provide estimated costs or qualitative or quantitative indication of the value of the changes or consequences to the human well-being	Required	Free text (max. 2500 characters). Indicate any residual impacts that may be generated.
CostDegradation	RelatedIndicator	Indicators used within the assessment	Required (where applicable)	Enter as many indicator codes as necessary (as reported by MS under the schema Indicators.xml).

d) ART10_Targets

According to what has been described in section 3.6, Figure 5 represents the structure of the schema.

Figure 5 XSD diagram of 'ART10_Targets'

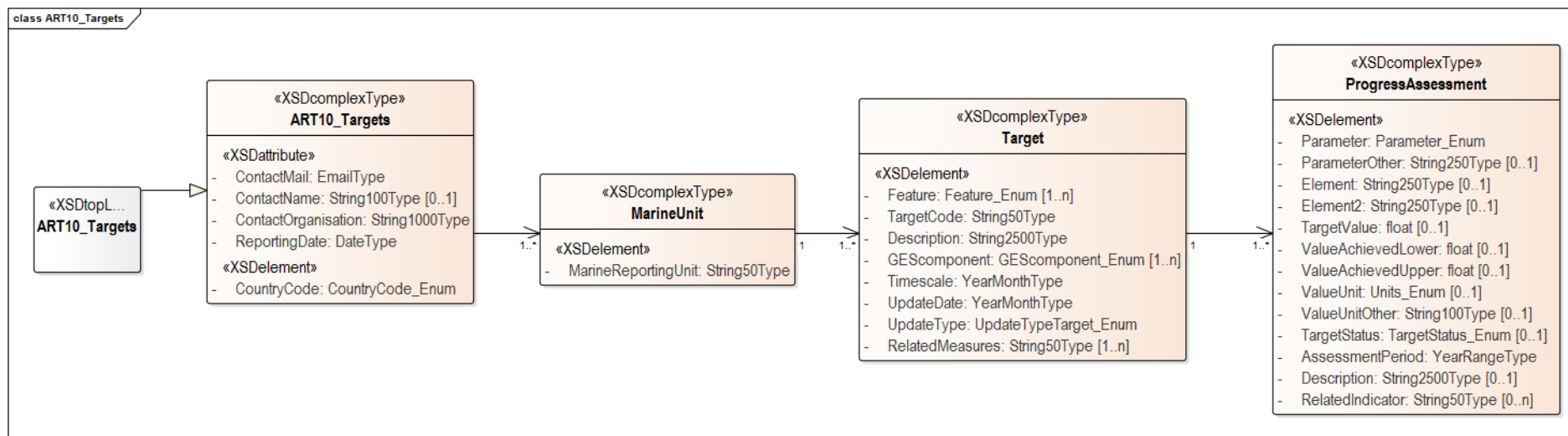

Based on the schema, Table 10 provides the details of the schema fields.

Table 10 Fields of the schema 'ART10_Targets'

Schema class	Schema field	Description	Property	Guidance
MarineUnit	MarineReportingUnit	Area where the Target applies	Required	Enter the Marine Reporting Unit code (MarineUnitID as reported by MS in 4geo.xml file, or select from the Marine Reporting Units list).
Target	Feature	Feature(s) to which the Target applies	Required (more than one value is allowed)	Enter as many Features as needed from List: Feature_Enum.
Target	TargetCode	Code used for the Target	Required	Enter target code as reported by MS in 2012. If it's a new target, enter a new code (max. 50 characters).
Target	Description	Description of the Target	Required	Free text (max. 2500 characters).
Target	GEScomponent	Descriptor or Criteria to	Required (more than one)	Enter corresponding 'Descriptor' OR 'Criteria' code from List:

Schema class	Schema field	Description	Property	Guidance
		which the target applies	value is allowed)	GEScomponent_Enum.
Target	Timescale	Timescale for achievement of the Target	Required	YYYYMM
Target	UpdateDate	Date where the Target has been officially adopted	Required	YYYYMM
Target	UpdateType	Report on whether the Target reported under Description is as per 2012, modified from the 2012 definition, new or no longer needed	Required	Enter: 'Same as 2012 definition', 'Modified from 2012 definition', 'New target' OR 'Target no longer needed'. For latter option, explain the reason for this under ProgressAssessment: Description.
Target	RelatedMeasures	Measure(s) codes that have been defined to achieve the target	Required	Enter as many measure codes as necessary (as reported by MS under the Programmes of Measures reporting). In the case of new targets, if they are not related to any measure, enter 'NotApplicable'.
ProgressAssessment	Element	Specific element covered (species, habitat, contaminant...) by the target	Required (where applicable)	Enter the name for species (D1, D2, D3), habitat (D1, D6), determinand (D5, D8, D9) or litter category (D10) (max. 250 characters).
ProgressAssessment	Element2	Additional element that is part of the measurement	Conditional: when GEScomponent is 'D3' (stocks) OR 'D9' (species)	Enter the name for stock (D3) and species (D9) (max. 250 characters).
ProgressAssessment	Parameter	Parameter assessed	Required	Enter code from List: Parameters_Enum.
ProgressAssessment	ParameterOther	Parameter assessed	Conditional (if Parameter is 'Other')	Free text (max. 250 characters).
ProgressAssessment	TargetValue	Value defined as Target (for quantified targets)	Optional (where available)	Number

Schema class	Schema field	Description	Property	Guidance
ProgressAssessment	ValueAchievedUpper	Value(s) resulting from monitoring. Where applicable, provide a range.	Optional (where available)	Number
ProgressAssessment	ValueAchievedLower			
ProgressAssessment	ValueUnit	Unit in which the value is expressed	Conditional: required when ValueAchieved is provided	Enter code from List: Units_Enum.
ProgressAssessment	ValueUnitOther	Unit in which the value is expressed	Conditional (if ValueUnit is 'Other')	Free text (max. 20 characters)
ProgressAssessment	TargetStatus	Indicate whether the Target value has been achieved or not	Required (where applicable)	Select: 'Target achieved' OR 'Target not yet achieved'.
ProgressAssessment	AssessmentPeriod	Start and end date of the 6-year assessment	Required	YYYY-YYYY
ProgressAssessment	Description	Description or comment on the assessment outcomes	Optional	Free text (max. 2500 characters). When 'Target no longer needed' is entered under 'UpdateType', provide an explanation here.
ProgressAssessment	RelatedIndicator	Indicator(s) used to assess progress towards target	Required (where applicable)	Enter as many indicator codes as necessary (as reported by MS under the schema Indicators.xml).

e) Indicators

According to what has been described in section 3.7, Figure 6 represents the structure of the schema.

Figure 6 XSD diagram of 'Indicators'

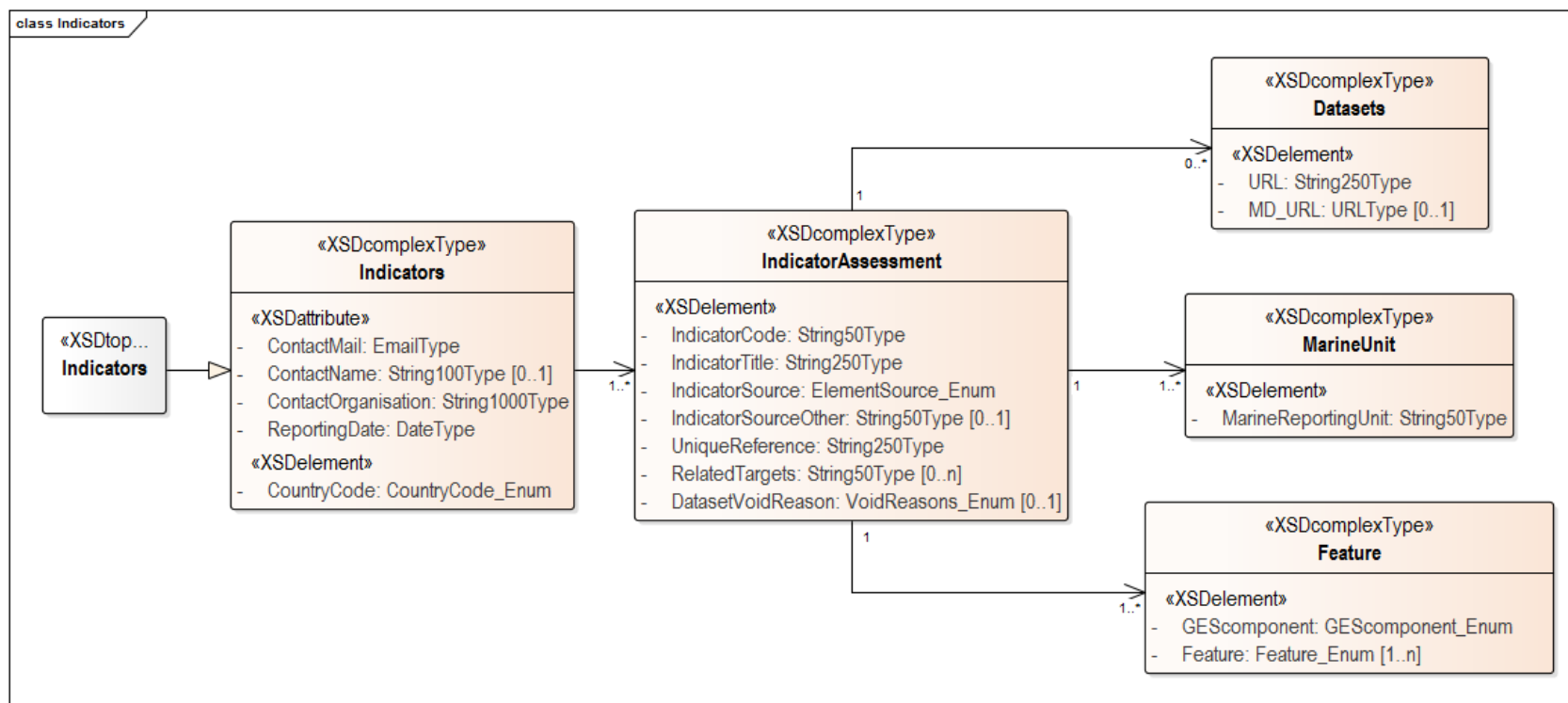

Based on the schema, Table 11 provides the details of the schema fields.

Table 11 Fields of the schema 'Indicators'

Schema class	Schema field	Description	Property	Guidance
IndicatorAssessment	IndicatorCode	Unique identifier for the indicator	Required	Use sub(region) code <u>plus</u> RSC/MS code <u>plus</u> defined alpha-numeric code (e.g. ABI-OSPAR-Nutrients2017) (max. 50 characters). When a regional indicator that is published is used, enter the regional code. If the regional indicator hasn't been published and there is a national

Schema class	Schema field	Description	Property	Guidance
				indicator, enter the national code.
IndicatorAssessment	IndicatorTitle	Title of indicator	Required	Free text (max. 250 characters).
IndicatorAssessment	IndicatorSource	Indicate the source of the indicator assessment	Required	Enter: 'EU', 'HELCOM', 'OSPAR', 'BARCON', 'BSC', 'ICES', 'GFCM', 'National', OR 'Other'.
IndicatorAssessment	IndicatorSourceOther	Indicate the source of the indicator assessment	Conditional (if IndicatorSource is 'Other')	Free text (max. 50 characters).
IndicatorAssessment	UniqueReference	Citable reference unique to resource	Required	Provide the URI or DOI as unique reference of the indicator (max. 250 characters).
IndicatorAssessment	RelatedTargets	Target to which the indicator is linked	Conditional: required when the indicator is applicable to Article 10	Enter the relevant target code (as reported by MS under the schema ART10_Targets.xml) (max. 50 characters).
IndicatorAssessment	DatasetVoidReason	Given reason not to report any dataset	Conditional: required when dataset are not reported	Enter: 'Data being prepared for publication', 'Data not publicly accessible' OR 'Data not in an electronic format'.
Feature	GEScomponent	Descriptor or Criteria relevant to the indicator	Required	Enter corresponding 'Descriptor' OR 'Criteria' from List: GEScomponent_Enum.
Feature	Feature	Feature(s) to which the indicator applies	Required	Enter as many Features as needed from List: Feature_Enum.
MarineUnit	MarineReportingUnit	Area(s) where the indicator applies	Required	Enter as many Marine Reporting Unit codes as needed (MarineUnitID as reported by MS in 4geo.xml file, or select from the Marine Reporting Units list).
Datasets	URL	Unique reference identifier of the dataset	Required	Provide the URI or DOI where the dataset or web service can be accessed. Link to the relevant data from Article 11 monitoring programme and to the dataset used for the indicator assessment.
Datasets	MD_URL	Unique resource locator for the metadata	Optional	URL where the metadata of the dataset or web service are discoverable.

ANNEX IV: Enumeration lists

a) CountryCode_Enum

Code	Lable: Country name
AT	Austria
BE	Belgium
BG	Bulgaria
CY	Cyprus
CZ	Czech Republic
DE	Germany
DK	Denmark
EE	Estonia
EL	Greece
ES	Spain
FI	Finland
FR	France
HR	Croatia
HU	Hungary
IE	Ireland
IT	Italy
LT	Lithuania
LU	Luxembourg
LV	Latvia
MT	Malta
NL	Netherlands
PL	Poland
PT	Portugal
RO	Romania
SE	Sweden
SI	Slovenia
SK	Slovakia
UK	United Kingdom

b) Feature_Enum

The present enumeration includes features and elements listed in MSFD Annex III tables, as well as the features corresponding to the pressures levels and impacts in the marine environment to be used within the GES assessments, and a list of ecosystem services that may be relevant for the reporting of the Economic and social analysis.

The features for which a GES determination and a GES conclusion is expected to be provided under ART9_GES and ART8_GES schemas respectively are highlighted in bold blue (for more information, see [Annex VI](#)). The broad habitat types are expected to be reported as Elements within ART8_GES schema.

The rest of the features have been listed for their potential use under the schemas ART8_ESA, ART10_Targets and Indicators.

The list of ecosystem services is based on an unpublished work from 'Culhane *et al*' (ETC-ICM).

Subject (Annex III table)	Theme	Sub-theme	Label: Features and elements	Code	
Structure, functions and processes of marine ecosystems (Table 1)	Species		All marine ecosystem elements	EcosysElemAll	
			All marine species	SppAll	
		Birds	All birds	BirdsAll	
			Grazing birds	BirdsGrazing	
			Wading birds	BirdsWading	
			Surface-feeding birds	BirdsSurfaceFeeding	
			Pelagic-feeding birds	BirdsPelagicFeeding	
			Benthic-feeding birds	BirdsBenthicFeeding	
			Mammals	All mammals	MamAll
		Small toothed cetaceans		MamCetacSmall	
		Deep-diving toothed cetaceans		MamCetacDeepDiving	
		Baleen whales		MamCetacBaleenWhales	
		Seals		MamSeals	
		Reptiles	Turtles	RepTurtles	
		Fish	All fish	FishAll	
			Coastal fish	FishCoastal	
			Pelagic shelf fish	FishPelagicShelf	
			Demersal shelf fish	FishDemersalShelf	
			Deep-sea fish	FishDeepSea	
			Commercially exploited fish and shellfish	FishCommercial	
		Cephalopods	All cephalopods	CephaAll	
			Coastal/shelf cephalopods	CephaCoastShelf	
			Deep-sea cephalopods	CephaDeepSea	
		Habitats		All habitats	HabAll
			Benthic habitats	Benthic habitats	HabBenAll
				Benthic broad habitats	HabBenBHT
				Littoral rock and biogenic reef	HabBenLitRock
				Littoral sediment	HabBenLitSed
				Infralittoral rock and biogenic reef	HabBenInfralitRock
				Infralittoral coarse sediment	HabBenInfralitCoarSed
				Infralittoral mixed sediment	HabBenInfralitMxdSed
				Infralittoral sand	HabBenInfralitSand
				Infralittoral mud	HabBenInfralitMud
	Circalittoral rock and biogenic reef			HabBenCircalitRock	
	Circalittoral coarse sediment			HabBenCircalitCoarSed	
	Circalittoral mixed sediment			HabBenCircalitMxdSed	
	Circalittoral sand			HabBenCircalitSand	
	Circalittoral mud			HabBenCircalitMud	
	Offshore circalittoral rock and biogenic reef			HabBenOffshRock	
	Offshore circalittoral coarse sediment			HabBenOffshCoarSed	
	Offshore circalittoral mixed sediment			HabBenOffshMxdSed	
	Offshore circalittoral sand			HabBenOffshSand	
	Offshore circalittoral mud			HabBenOffshMud	
	Upper bathyal rock and biogenic reef			HabBenBathyalUpRock	
	Upper bathyal sediment			HabBenBathyalUpSed	
	Lower bathyal rock and biogenic reef			HabBenBathyalLowRock	
	Lower bathyal sediment			HabBenBathyalLowSed	
	Abyssal			HabBenAbyssal	
	Other benthic habitats			HabBenOther	
	Pelagic habitats			Pelagic habitats	HabPelagAll
			Pelagic broad habitats	HabPelBHT	
			Variable salinity	HabPelagVarSalinity	
			Coastal	HabPelagCoastal	
Shelf			HabPelagShelf		
Oceanic/beyond shelf			HabPelagOcean		

Subject (Annex III table)	Theme	Sub-theme	Label: Features and elements	Code	
			Other pelagic habitats	HabPelagOther	
			Other habitat types	HabOther	
	Ecosystems, including food webs	Physical and hydrological characteristics	All physical and hydrological characteristics	PhyHydroCharacAll	
			Temperature	Temperature	
			Ice	Ice	
			Wave regime	Waves	
			Current regime	Currents	
			Upwelling	Upwelling	
			Mixing	Mixing	
			Residence time	ResidenceTime	
			Freshwater input	FreshwaterInput	
			Sea level	SeaLevel	
			Bathymetry	Bathymetry	
			Turbidity (silt/sediment loads)	Turbidity	
			Transparency	Transparency	
			Sound	Sound	
			Seabed substrate and morphology	SubstrateMorphology	
			Chemical characteristics	All chemical characteristics	ChemCharacAll
		Salinity		Salinity	
		Nutrients (N, P)		Nutrients	
		Organic carbon		OrganicCarbon	
		Dissolved carbon dioxide (pCO ₂)		pCO2	
		Dissolved oxygen		Oxygen	
		Trophic guilds	All trophic guilds	TrophicGuildsAll	
			Primary producers	TrophicGuildsPrimProd	
			Secondary producers	TrophicGuildsSecProd	
			Filter-feeders	TrophicGuildsFilFeed	
			Deposit-feeders	TrophicGuildsDepFeed	
			Planktivores	TrophicGuildsPlankt	
			Sub-apex pelagic predators	TrophicGuildsPredSApexPel	
			Sub-apex demersal predators	TrophicGuildsPredSApexDem	
		Ecosystems	Ecosystem, including food webs	EcosystemFoodWeb	
			Coastal ecosystem	EcosysCoastal	
			Shelf ecosystem	EcosysShelf	
			Oceanic/deep-sea ecosystem	EcosysOceanic	
		Anthropogenic pressures on the marine environment (Table 2a)	Biological	All pressures	PresAll
				All biological pressures	PresBioAll
				Input or spread of non-indigenous species	PresBioIntroNIS
	Input of microbial pathogens			PresBioIntroMicroPath	
	Input of genetically modified species and translocation of native species			PresBioIntroGenModSpp	
	Loss of, or change to, natural biological communities due to cultivation of animal or plant species			PresBioCultHab	
	Disturbance of species (e.g. where they breed, rest and feed) due to human presence			PresBioDisturbSpp	
Extraction of, or mortality/injury to, wild species (by commercial and recreational fishing and other activities)	PresBioExtractSpp				
Physical	All physical pressures			PresPhyAll	
	Physical disturbance to seabed			PresPhyDisturbSeabed	
	Physical loss of the seabed			PresPhyLoss	

Subject (Annex III table)	Theme	Sub-theme	Label: Features and elements	Code	
	Substances, litter and energy		Changes to hydrological conditions	PresPhyHydroCond	
			All pressures related to inputs of substances, litter and energy	PresInputAll	
			Input of nutrients – diffuse sources, point sources, atmospheric deposition	PresInputNut	
			Input of organic matter – diffuse sources and point sources	PresInputOrg	
			Input of other substances (e.g. synthetic substances, non-synthetic substances, radionuclides) – diffuse sources, point sources, atmospheric deposition, acute events	PresInputCont	
			Input of litter (solid waste matter, including micro-sized litter)	PresInputLitter	
			Input of anthropogenic sound (impulsive, continuous)	PresInputSound	
			Input of other forms of energy (including electromagnetic fields, light and heat)	PresInputOthEnergy	
			Input of water – point sources (e.g. brine)	PresInputWater	
Pressure levels and impacts in marine environment	Biological		Newly-introduced non-indigenous species	PresEnvNISnew	
			Established non-indigenous species	PresEnvNISestablished	
	Physical and hydrological		Hydrographical changes	PresEnvHydroChanges	
		Substances, litter and energy		Eutrophication	PresEnvEutrophi
				Contaminants - non UPBT substances	PresEnvContNonUPBTs
				Contaminants - UPBT substances	PresEnvContUPBTs
				Contaminants – in seafood	PresEnvContSeafood
				Acute pollution events	PresEnvAcuPolluEvents
				Litter in the environment	PresEnvLitter
				Micro-litter in the environment	PresEnvLitterMicro
	Litter and micro-litter in species		PresEnvLitterSpp		
	Impulsive sound in water	PresEnvSoundImpulsive			
	Continuous low frequency sound	PresEnvSoundContinuous			
Uses and human activities in or affecting the marine environment (Table 2b)			All activities	ActivAll	
		Physical restructuring of rivers, coastline or seabed (water management)		All activities related to physical restructuring of rivers, coastline or seabed	ActivRestrucAll
				Land claim	ActivRestrucLandClaim
				Canalisation and other watercourse modifications	ActivRestrucCanalisation
				Coastal defence and flood protection	ActivRestrucCoastDef
				Offshore structures (other than for oil/gas/renewables)	ActivRestrucOffshStruc
				Restructuring of seabed morphology, including dredging and depositing of materials	ActivRestrucSeabedMorph
		Extraction of non-living resources		All activities related to extraction of non-living resources	ActivExtrNonLivingAll
				Extraction of minerals (rock, metal ores, gravel, sand, shell)	ActivExtrNonLivingMinerals
				Extraction of oil and gas, including infrastructure	ActivExtrNonLivingOilGas
				Extraction of salt	ActivExtrNonLivingSalt
				Extraction of water	ActivExtrNonLivingWater
		Production of energy		All activities related to production of energy	ActivProdEnerAll
	Renewable energy generation (wind, wave and tidal power), including infrastructure		ActivProdEnerRenew		

Subject (Annex III table)	Theme	Sub-theme	Label: Features and elements	Code		
			Non-renewable energy generation	ActivProdEnerNonRenew		
			Transmission of electricity and communications (cables)	ActivProdEnerCables		
	Extraction of living resources			All activities related to extraction of living resources	ActivExtrLivingAll	
				Fish and shellfish harvesting (professional, recreational)	ActivExtrLivingFishHarv	
				Fish and shellfish processing	ActivExtrLivingFishProcess	
				Marine plant harvesting	ActivExtrLivingPlantHarv	
				Hunting and collecting for other purposes	ActivExtrLivingHunt	
	Cultivation of living resources			All activities related to cultivation of living resources	ActivCultivAll	
				Aquaculture – marine, including infrastructure	ActivCultivAquaculMarine	
				Aquaculture – freshwater	ActivCultivAquaculFreshwa	
				Agriculture	ActivCultivAgri	
	Transport			Forestry	ActivCultivFores	
				All activities related to transport	ActivTranspAll	
				Transport infrastructure	ActivTranspInfras	
				Transport – shipping	ActivTranspShip	
				Transport – air	ActivTranspAir	
	Urban and industrial uses			Transport – land	ActivTranspLand	
				All urban and industrial uses	ActivUrbIndAll	
				Urban uses	ActivUrbIndUrban	
				Industrial uses	ActivUrbIndIndustrial	
	Tourism and leisure			Waste treatment and disposal	ActivUrbIndWaste	
				All activities related to tourism and leisure	ActivTourismAll	
				Tourism and leisure infrastructure	ActivTourismInfras	
	Security/defence			Tourism and leisure activities	ActivTourismActiv	
				Military operations (subject to Article 2(2))	ActivMilitary	
	Education and research			Research, survey and educational activities	ActivResearch	
	Ecosystem services			All ecosystem services	EcosysServAll	
Nutrition				Biomass	All ecosystem services related to nutrition	EcosysServNutrAll
					Wild plants, algae and their outputs	EcosysServNutrSeafoodAlgae
					Wild animals and their outputs	EcosysServNutrSeafoodAnim als
					Algal seafood from aquaculture	EcosysServNutrAquacAlgae
					Animals from in-situ aquaculture	EcosysServNutrAquacAnimal s
Materials				Biomass	All ecosystem services related to provision of materials	EcosysServMatAll
					Fibres and other materials from plants, algae and animals for direct use or processing	EcosysServMatRaw
					Materials from plants, algae and animals for agricultural use	EcosysServMatAlgaeAnimals ForAquac
					Genetic materials from all biota	EcosysServMatGenetic
Energy				Biomass-based energy sources	All ecosystem services related to provision of energy	EcosysServEnerAll
					Plant-based resources	EcosysServEnerPlants
					Animal-based resources	EcosysServEnerAnimals
Mediation of waste, toxics and other				Mediation by biota	All ecosystem services related to mediation of waste, toxics and other nuisances	EcosysServWasteAll
					Bio-remediation by micro-organisms, algae, plants, and animals	EcosysServWasteTreatment

Subject (Annex III table)	Theme	Sub-theme	Label: Features and elements	Code
	nuisances		Filtration/sequestration/storage/accumulation by micro-organisms, algae, plants, and animals	EcosysServWasteRemovalByOrgan
		Mediation by ecosystems	Filtration/sequestration/storage/accumulation by ecosystems	EcosysServWasteRemovalByEcosys
			Mediation of smell/visual impacts	EcosysServWasteSmellVismImpacts
	Mediation of flows		All ecosystem services related to mediation of flows	EcosysServFlowsAll
		Mass flows	Mass stabilisation and control of erosion rates	EcosysServFlowsErosionPrev1
			Buffering and attenuation of mass flows	EcosysServFlowsErosionPrev2
		Liquid flows	Flood protection	EcosysServFlowsFloodProt
		Gaseous / air flows	Ventilation and transpiration	EcosysServFlowsOxygenProd
	Maintenance of physical, chemical, biological conditions		All ecosystem services related to maintenance of physical, chemical and biological conditions	EcosysServMainCondAll
		Lifecycle maintenance, habitat and gene pool protection	Pollination and seed dispersal	EcosysServMainCondPolli
			Maintaining Nursery Populations and Habitats	EcosysServMainCondNurs
			Gene pool protection	EcosysServMainCondGene
		Pest and disease control	Pest control	EcosysServMainCondPest
			Disease control	EcosysServMainCondDis
		Soil formation and composition	Decomposition and fixing processes	EcosysServMainCondDeco
		Water conditions	Chemical condition of salt waters	EcosysServMainCondChem
	Atmospheric composition and climate regulation	Global climate regulation by reduction of greenhouse gas concentrations	EcosysServMainCondClim	
	Underpinning and/or enhancing physical and intellectual interactions		All ecosystem services underpinning physical and intellectual interactions	EcosysServInteracPhyAll
		Physical and experiential interactions	Experiential use of plants, animals and land-/seascapes in different environmental settings	EcosysServInteracPhyRecreat1
			Physical use of land-/seascapes in different environmental settings	EcosysServInteracPhyRecreat2
		Intellectual and representative interactions	Scientific	EcosysServInteracPhyScientif
			Educational	EcosysServInteracPhyEducat
			Heritage, cultural	EcosysServInteracPhyCultur
Entertainment			EcosysServInteracPhyEntert	
Aesthetic			EcosysServInteracPhyAesthe	
Underpinning and/or enhancing spiritual, symbolic and other interactions			All ecosystem services underpinning spiritual, symbolic and other interactions	EcosysServInteracSpiAll
		Spiritual and/or emblematic	Symbolic	EcosysServInteracSpiSymb
	Sacred and/or religious		EcosysServInteracSpiRelig	
	Other cultural outputs	Existence	EcosysServInteracSpiExis	
		Bequest	EcosysServInteracSpiBequ	

c) GEScomponent_Enum

GEScomponne	Code	Label: Descriptor or criterion
Descriptor	D1	D1 Biodiversity
Descriptor	D1	D1 Biodiversity - birds
Descriptor	D1	D1 Biodiversity - cephalopods
Descriptor	D1	D1 Biodiversity - fish
Descriptor	D1	D1 Biodiversity - mammals
Descriptor	D1	D1 Biodiversity - reptiles
Descriptor	D1	D1 Biodiversity – pelagic habitats
Descriptor	D2	D2 Non-indigenous species
Descriptor	D3	D3 Commercial fish and shellfish
Descriptor	D4/D1	D4 Food webs/D1 Biodiversity - ecosystems
Descriptor	D5	D5 Eutrophication
Descriptor	D6/D1	D6 Sea-floor integrity/D1 Biodiversity - benthic habitats
Descriptor	D7	D7 Hydrographical changes
Descriptor	D8	D8 Contaminants
Descriptor	D9	D9 Contaminants in seafood
Descriptor	D10	D10 Marine litter
Descriptor	D11	D11 Energy, including underwater noise
Criterion	D1C1	D1C1 Mortality rate from incidental by-catch
Criterion	D1C2	D1C2 Population abundance
Criterion	D1C3	D1C3 Population demographic characteristics
Criterion	D1C4	D1C4 Population distributional range and pattern
Criterion	D1C5	D1C5 Habitat for the species
Criterion	D1C6	D1C6 Pelagic habitat condition
Criterion	D2C1	D2C1 Newly-introduced NIS
Criterion	D2C2	D2C2 Established NIS
Criterion	D2C3	D2C3 Adverse effects of NIS
Criterion	D3C1	D3C1 Fishing mortality rate (F)
Criterion	D3C2	D3C2 Spawning stock biomass (SSB)
Criterion	D3C3	D3C3 Population age/size distribution
Criterion	D4C1	D4C1 Trophic guild species diversity
Criterion	D4C2	D4C2 Abundance across trophic guilds
Criterion	D4C3	D4C3 Trophic guild size distribution
Criterion	D4C4	D4C4 Trophic guild productivity
Criterion	D5C1	D5C1 Nutrient concentrations
Criterion	D5C2	D5C2 Chlorophyll a concentration
Criterion	D5C3	D5C3 Harmful algal blooms
Criterion	D5C4	D5C4 Photic limit
Criterion	D5C5	D5C5 Dissolved oxygen concentration
Criterion	D5C6	D5C6 Opportunistic macroalgae of benthic habitats
Criterion	D5C7	D5C7 Macrophyte communities of benthic habitats
Criterion	D5C8	D5C8 Macrofaunal communities of benthic habitats

GEScomponne	Code	Label: Descriptor or criterion
Criterion	D6C1	D6C1 Physical loss of the seabed
Criterion	D6C2	D6C2 Physical disturbance to the seabed
Criterion	D6C3	D6C3 Adverse effects from physical disturbance
Criterion	D6C4	D6C4 Benthic habitat extent
Criterion	D6C5	D6C5 Benthic habitat condition
Criterion	D7C1	D7C1 Permanent alteration of hydrographical conditions
Criterion	D7C2	D7C2 Adverse effects from permanent alterations of hydrographical
Criterion	D8C1	D8C1 Contaminant in environment
Criterion	D8C2	D8C2 Adverse effects of contaminants
Criterion	D8C3	D8C3 Significant acute pollution events
Criterion	D8C4	D8C4 Adverse effect of significant acute pollution events
Criterion	D9C1	D9C1 Contaminants in seafood
Criterion	D10C1	D10C1 Litter (excluding micro-litter)
Criterion	D10C2	D10C2 Micro-litter
Criterion	D10C3	D10C3 Litter ingested
Criterion	D10C4	D10C4 Adverse effects of litter
Criterion	D11C1	D11C1 Anthropogenic impulsive sound
Criterion	D11C2	D11C2 Anthropogenic continuous low-frequency sound
Indicator (old)	1.1.3	1.1.3 Area covered by the species (for sessile/benthic species)
Indicator (old)	1.3.2	1.3.2 Population genetic structure
Criterion (old)	1.4	1.4 Habitat distribution
Indicator (old)	1.4.1	1.4.1 Distributional range
Indicator (old)	1.4.2	1.4.2 Distributional pattern
Indicator (old)	1.5.2	1.5.2 Habitat volume
Indicator (old)	3.3.2	3.3.2 Mean maximum length across all species found in research vessel
Indicator (old)	5.1.2	5.1.2 Nutrient ratios (silica, nitrogen and phosphorus)
Criterion (old)	5.2	5.2 Direct effects of nutrient enrichment
Criterion (old)	5.3	5.3 Indirect effects of nutrient enrichment
Indicator (old)	9.1.2	9.1.2 Frequency of regulatory levels being exceeded
	NotRelevant	GES component not relevant

d) IntegrationRule_Enum

Type	Code	Label	Description
Conditional Rule (CR) methods	OOAO	One-out-all-out (OOAO)	All variables have to achieve good status.
	OOAO_HIE	Hierarchical application of OOA	'High-level integration' assessment results for three groups: biological indicators, hazardous substances, indicators and supporting indicators, each applying OOA.
	2OAO	Two-out all-out	If two variables do not meet the required standard, good status is not achieved.
	THRES	Threshold methods	A specific proportion of the variables have to achieve good status.

Type	Code	Label	Description
	TREE	Decision tree approach	Uses specific decision rules to integrate elements into a quality assessment.
Averaging Approach (AA) methods	NHIE_NWEI	Non-hierarchical, non-weighted averaging	Combination of variables/indicators into a flat structure with no intermediate aggregation. Weightings are equal for all indicators and is atypical approach used when there is not enough information on the influence of individual indicators. This method is the most basic of quantitative aggregations, and is more common for indicator production. Averaging can be arithmetic or geometric.
	NHIE_WEI	Non-hierarchical, weighted averaging	Combination of variables/indicators into a flat structure with no intermediate aggregation. Weightings are variable between indicators and can be allocated according to multivariate analysis, expert judgement or based on theoretical assumptions regarding value.
	HIE_NWEI	Hierarchical, non-weighted averaging	The use of hierarchical approaches to structure indicator inclusion and group is very common. The added structure provides the ability to output intermediate CIs that aid in the interpretation of the overall CI/AI. The nesting of associated indicators into clusters greatly improves the clarity of the aggregation process. Weightings are equal for each indicator and typical of when there is not enough information on the influence of individual indicators.
	HIE_WEI	Hierarchical, weighted averaging	Hierarchical layers and clustering of input indicators is used to structure and order the aggregation. Weightings are variable between indicators and can be allocated according to multivariate analysis, expert judgement or based on theoretical assumptions regarding value. Weights can be applied to either individual indicators or to clustered indicators.
Non-Averaging Approach (NAA)	MULTIMETRIC	Multi-metric indices	Often hierarchically-structured and have inputs clustered by metric. Weights can be variable or equal. Calculation is undertaken with complex approaches such as summation, multiplication or bespoke formulae operations.
	MULTIVARIATE	Multivariate analyses	Use predefined statistical procedures. Commonly applied methods include Factor Analysis, Discriminate analysis and Principal Components Analysis
Other	SPATIAL	Spatial analysis	Spatial analysis where layers are combined using different functions to produce an integrated output.
	OTH	Other	Other integration methods.

These methods are described in: Barnard, S. & Strong, J., (2014), Reviewing, refining and identifying optimum aggregation methods for undertaking marine biodiversity status assessments, JNCC Report 536, ISSN 0963 8901 (URL: http://jncc.defra.gov.uk/pdf/Report_536_Print.pdf).

The table was adapted from an earlier catalogue of aggregation approaches developed in: Prins, T., van der Meulen, M., Boon, A., Simboura, N., Tsangaris, C., Borja, A. & Menchaca, I. (2013) Coherent geographic scales and aggregation rules in assessment and monitoring of Good Environmental Status – analysis and conceptual phase. Report number 1207879-000. Deltares; Delft, NL. 61pp ([Coherent geographic scales and aggregation rules- guidance report Final 31 October 2014.pdf](#))

e) MarineLitterCategories_Enum

TYPE	Code	Label
MACROLITTER	ARTPOLY	Artificial polymer materials
	RUBBER	Rubber
	TEXTILE	Cloth/textile
	PAPER	Paper/cardboard
	WOOD	Processed/worked wood
	METAL	Metal
	GLASS	Glass/ceramics
	CHEM	Chemicals
	FOOD	Food waste
UNDEF	Undefined	
MICROLITTER	ARTPOLY	Artificial polymer materials
	OTHER	Other materials

f) Parameters_Enum

Non-exhaustive list of parameters:

CODE	Parameter label	Applicable elements	Applicable unit	Applicable criteria	Applicable metric	Observations
ABU	Abundance (number of individuals)	Species	{individuals}	D1C2	count	
		NIS	{individuals}	D2C2	count	all NIS
		Commercial stocks	{individuals}	D3C2	count	
		Trophic guild	{individuals}	D4C2	count	
		Species (opportunistic macroalgae)	{individuals}	D5C6	count	adverse effects of nutrient enrichment
		Species	EQR	D5C6; D5C7; D5C8	ratio	
AGE-D	Age distribution	Species	%	D1C3	percentage	
AMO-B	Amount in biota (ingested)	Marine litter	items/kg	D10C3	count	per species mass
		Marine litter	items/cm	D10C3	count	per species length
AMO-SB	Amount on seabed	Macrolitter	items/km ²	D10C1	count	
		Microlitter	items/kg dw	D10C2	count	
AMO-C	Amount on coastline	Macrolitter	items/100m	D10C1	count	per 100 m for the coastline
		Microlitter	items/kg dw	D10C2	count	
AMO-WS	Amount on water surface	Macrolitter	items/km ²	D10C1	count	
		Microlitter	items/m ²	D10C2	count	

CODE	Parameter label	Applicable elements	Applicable unit	Applicable criteria	Applicable metric	Observations
BIOM	Biomass	Species	T	D1C2	sum	
		NIS	T	D2C2	sum	
		Trophic guild	T	D4C2	sum	
CONC-B	Concentration in biota (total)	Contaminants	ug/kg ww; mg/kg ww; pg/g ww	D8C1; D9C1	maximum level	Including foodstuff
CONC-B-FA	Concentration in biota - fat	Contaminants	ug/kg ww; mg/kg ww; pg/g ww	D8C1; D9C1	maximum level	Including foodstuff
CONC-B-LI	Concentration in biota - liver	Contaminants	ug/kg ww; mg/kg ww; pg/g ww	D8C1; D9C1	maximum level	Including foodstuff
CONC-B-MU	Concentration in biota - muscle	Contaminants	ug/kg ww; mg/kg ww; pg/g ww	D8C1; D9C1	maximum level	Including foodstuff
CONC-B-OT	Concentration in biota - other	Contaminants	ug/kg ww; mg/kg ww; pg/g ww	D8C1; D9C1	maximum level	Including foodstuff
CONC-S	Concentration in sediment (total)	Contaminants	ug/kg dw	D8C1	undefined	
CONC-S-20	Concentration in sediment (fraction below 20 µm)	Contaminants	ug/kg dw	D8C1	undefined	
CONC-S-63	Concentration in sediment (fraction below 63 µm)	Contaminants	ug/kg dw	D8C1	undefined	
CONC-S-2000	Concentration in sediment (fraction below 2000 µm)	Contaminants	ug/kg dw	D8C1	undefined	
CONC-S-OT	Concentration in sediment - other	Contaminants	ug/kg dw	D8C1	undefined	
CONC-W	Concentration in water	Nutrients	umol/L	D5C1	undefined	
		Chlorophyll a	ug/L	D5C2	undefined	metric used under the WFD: p90 is used in at least 2 GIGs (MED and NEA)
		Dissolved oxygen	mg/L	D5C5	undefined	
		Contaminants	ug/L	D8C1	undefined	
DIST-P	Distribution (pattern)	Species	no unit	D1C4	adimensional	
DIST-S	Distribution (spatial)	Species	no unit	D1C4	geographical area	

CODE	Parameter label	Applicable elements	Applicable unit	Applicable criteria	Applicable metric	Observations
DIST-R	Distribution (range)	Species (range)	%	D1C4	percentage	
DUR	Duration	Anthropogenic impulsive sound in water	D	D11C1	count (quarterly OR monthly)	impulsive sound
		Bloom events	D/y	D5C3	count	
		Acute pollution events	D/y	D8C3	count	
EXT	Extent	Habitats (for species)	km ²	D1C5	sum	
		Habitats	km ²	D1C6	sum	adverse effects
		Habitats area	%	D1C6; D6C4; D6C5	percentage	adverse effects
		NIS	km ²	D2C2	sum	
		NIS	km ²	D2C3	sum	adverse effects
		Bloom events	km ²	D5C3	sum	
		Species (opportunistic macroalgae, macrophyte and macrofaunal communities)	km ²	D5C6; D5C7; D5C8	sum	adverse effects
		Area physically lost, disturbed or hydrographically altered	km ²	D6C1; D6C2; D7C1	sum	
		Habitat types	km ²	D6C3; D6C4; D6C5; D8C2; D8C4	sum	per broad habitat type affected
Acute pollution events	km ²	D8C3	sum			
FEC	Fecundity (breeding rate)	Colonies failing per year	%	D1C3	percentage	
FRE	Frequency	Bloom events	{events}/y	D5C3	count	
HAB-CON	Habitat condition	Habitats	EQR	D1C5; D1C6; D6C5; D7C2	value (0-1)	
INC	Incidence	NIS	no unit	D2C3	ratio	adverse effects within the species group
		Species	{individuals}	D8C2; D8C4	count	per species affected

CODE	Parameter label	Applicable elements	Applicable unit	Applicable criteria	Applicable metric	Observations
		Species	{individuals}	D10C4	count	per species affected (lethal; sublethal)
SIZE-LEN	Size (length)	Species	Cm	D1C3	body size	
		Stocks	Cm	D3C3	p95 of fish-length distribution (LFI)	
		Commercial stocks	Cm	D3C3	size at first sexual maturation	
LEV-N	Level of sound	Anthropogenic impulsive sound in water	dB re 1 μ Pa ²	D11C1	Average per quarter or month	
MASS	Mass	Marine litter	G	D10C3	sum	ingested by marine animals
		Microlitter	g/m ²	D10C2	sum	for surface layer of the water column
		Marine litter	g/cm	D10C3	sum	per species length
		Microlitter	g/kg dw	D10C2	sum	for the coastline and for seabed
		Marine litter	g/kg	D10C3	sum	per species mass
DIST-DEPTH	Maximum depth	Macrophyte communities	M	D5C7	Maximum value	
MOR/F	Mortality rate	Species	no unit	D1C1	ratio	
	Mortality rate from fishing (F)	Commercial stocks	no unit	D3C1	ratio	
THICK-BLU	Blubber thickness	Mammals	mm	D1C3	average	Indicator of the nutritional status
OTH	Other					
PRE	Presence	NIS	{species}	D2C1	count	newly introduced/6 years
PROD	Productivity	Trophic guild	g/m ² d	D4C4	sum	
ABU-REL	Relative abundance within community	NIS	%	D2C3	percentage	adverse effects
		Species (macrophyte and macrofaunal communities)	EQR	D5C7; D5C8	value (0-1)	adverse effects
		Trophic guilds	EQR	D4C2	value (0-1)	
SEX-D	Sex distribution	Species	no unit	D1C3	ratio	

CODE	Parameter label	Applicable elements	Applicable unit	Applicable criteria	Applicable metric	Observations
SIZE-D	Size distribution	Commercial stocks	%	D3C3	percentage of fish larger than mean size of first maturation	
		Species	EQR	D1C6	value (0-1)	
SPL	Underwater sound level	Anthropogenic sound in water	dB re 1 μ Pa per unit area	D11C2	annual average	continuous low-frequency sound
SPP-C	Species composition	Species (macrophyte and macrofaunal communities)	EQR	D5C7; D5C8	value (0-1)	
BIOM-SSB	Biomass of Spawning Stock (SSB)	Commercial stocks	T	D3C2	sum	Combined weight of all individuals in a fish stock that are capable of reproducing
SUR	Survival rate	Species	no unit	D1C3	ratio	
TRA	Transparency of water	Photic limit	M	D5C4	count	

g) ThresholdSources_Enum

Code	Label
BathingWater	Bathing Water Directive (76/160/EEC)
Birds	Birds Directive (2009/147/EC)
DrinkingWater	Drinking Water Directive (80/778/EEC) as amended by Directive (98/83/EC)
EIA Directive	Environmental Impact Assessment Directive (85/337/EEC)
Foodstuffs	Regulation on contaminants in foodstuffs (EC 1881/2006)
Habitats	Habitats Directive (92/43/EEC)
IPPC	Integrated Pollution Prevention Control Directive (96/61/EC)
Seveso	Major Accidents (Seveso) Directive (96/82/EC)
Nitrates	Nitrates Directive (91/676/EEC)
PPPP	Placing of plant protection products on the market (Regulation EC/1107/2007)
SSD	Sewage Sludge Directive (86/278/EEC)
UWWTD	Urban Waste Water Treatment Directive (91/271/EEC)
WaterFD	Water Framework Directive (2000/60/EC)
PSD	Priority substances Directive (2013/39/EU)
FD	Floods Directive (2007/60/EC)
IAER	Prevention and management of the introduction and spread of invasive alien species (Regulation 1143/2014)
WasteFD	Waste Framework Directive (2008/98/EC)
NEC	Directive on National Emission Ceilings for certain pollutants (2001/81/EC)
REACH	Regulation on Registration, Evaluation, Authorisation and Restriction of Chemicals (EC 1907/2006)
CFP	Common Fisheries Policy

Code	Label
CFP-DC-MAP	Common Fisheries Policy - Data Collection Framework (DC-MAP)
EUBiodivStrategy	EU Biodiversity Strategy
CBD	Convention on Biological Diversity
CMS	Convention on Migratory Species
LTRAP	UNECE Convention on long-range transboundary air pollution
HELCOM	Helsinki Convention
OSPAR	OSPAR Convention
BarCon	Barcelona Convention UNEP/MAP
BuchCon	Bucharest Convention
TWSC	Trilateral Wadden Sea Cooperation
GFCM	General Fisheries Commission for the Mediterranean
ICCAT	International Commission for the Conservation of Atlantic Tunas
NEAFC	North East Atlantic Fisheries Commission
IMO	International Maritime Organisation (MARPOL, Ballast Water Convention, Antifouling Convention)
MS(sub)region	MS within (sub)region
National	National
DirectionalTrends	Directional trends
PressureProxy	Pressure-based proxy
Other	Other (specify)
Not applicable	Not applicable

h) Units_Enum

Code	Label
%	percentage
Bq/kg ww	Becquerels per kilogram of wet weight
cm	centimetre
CPUE	Catch-Per-Unit-Effort
D	days
dB	decibel
dB re 1 μ Pa ²	Decibels reference 1 microPascal squared second
{events}/y	(number of) events per year
g/cm	gram per centimetre
g/kg	gram per kilogram
g/kg dw	gram per kilogram of dry weight
g/m ²	gram per square metre
g/m ² d	gram per square metre per day
{individuals}	(number of) individuals
items/cm	number of items per centimetre
items/kg	number of items per kilogram
items/kg dw	number of items per kilogram of dry weight
items/km ²	number of items per square kilometre
items/m	number of items per meter
items/m ²	number of items per square metre

Code	Label
km ²	square kilometre
m	metre
mm	millimetre
mg/kg	milligram per kilogram
mg/kg ww	milligram per kilogram of wet weight
mg/L	milligram per litre
pg/g ww	picogram per gram of wet weight
{ratio}	ratio
{species}	(number of) species
T	tonne
ug/kg dw	microgram per kilogram of dry weight
ug/kg ww	microgram per kilogram of wet weight
ug/L	microgram per litre
umol/L	micromole per litre
Other	other

i) ElementCodeSource

Code	Link	Conditional
WoRMS	http://www.marinespecies.org/	Species (D1)
CoL	http://www.catalogueoflife.org/	Species (D1)
Algaebase	http://www.algaebase.org	Species (D1)
HabitatsDirective: species	http://dd.eionet.europa.eu/vocabulary/biodiversity/n2000species/view	Species (D1)
BirdsDirective	http://dd.eionet.europa.eu/vocabulary/biodiversity/n2000birds/view	Species (D1)
FAO	http://www.fao.org/fishery/collection/asfis/en	Species (D3)
ICES-Stock	http://vocab.ices.dk/?ref=357	Species (D3)
BHT	http://dd.eionet.europa.eu/vocabulary/msfd/broadHabitatTypes/view	Habitats (D1-D6)
EUNIS	http://dd.eionet.europa.eu/vocabulary/biodiversity/eunishabitats/view	Habitats (D1-D6)
HabitatsDirective: habitats	http://dd.eionet.europa.eu/vocabulary/biodiversity/n2000habitats/view	Habitats (D1-D6)
HELCOMHabitats	http://maps.helcom.fi/website/HUB/HUB.html	Habitats (D1-D6)
OSPARHabitats	http://www.ospar.org/documents?d=32794	Habitats (D1-D6)
WISE	http://dd.eionet.europa.eu/vocabulary/wise/ObservedProperty/view	Eutrophication (D5) and contaminants (D8-D9)
WISE-B	http://dd.eionet.europa.eu/vocabulary/wise/ObservedPropertyBiologyEQR/view	Eutrophication (D5)(EQRs)
BODC-SDN	http://seadatanet.maris2.nl/v_bodc_vocab_v2/vocab_relations.asp?lib=P02	Contaminants (D8-D9)
ICES-Param	http://vocab.ices.dk/?ref=37	Contaminants (D8-D9)
Other	Link to other vocabulary or code lists that may be relevant	

j) NACECodes_Enum (indicative)

Sector	Code	Label
Fisheries and aquaculture	0311	Marine fishing
	0321	Marine aquaculture
	1020	Processing and preserving of fish, crustaceans and molluscs
Shipping (or maritime transport)	5010	Sea and coastal passenger water transport
	5020	Sea and coastal freight water transport
Ports	3011	Building of ships and floating structures
	3012	Building of pleasure and sporting boats
	3315	Repair and maintenance of ships and boats
	4671	Wholesale of solid, liquid and gaseous fuels and related products
	4672	Wholesale of metals and metal ores
	4673	Wholesale of wood, construction materials and sanitary equipment
	4674	Wholesale of hardware, plumbing and heating equipment and supplies
	4675	Wholesale of chemical products
	4676	Wholesale of other intermediate products
	4677	Wholesale of waste and scrap
	4211	Construction of roads and motorways
	4212	Construction of railways and underground railways
	4213	Construction of bridges and tunnels
	4221	Construction of utility projects for fluids
	4222	Construction of utility projects for electricity and telecommunications
	4291	Construction of water projects
	4299	Construction of other civil engineering projects n.e.c.
	5222	Service activities incidental to water transportation
Oil and Gas	0610	Extraction of crude petroleum
	0620	Extraction of natural gas
	0910	Support activities for petroleum and natural gas extraction
Marine mining (sand and gravel, rock)	0811	Quarrying of ornamental and building stone, limestone, gypsum, chalk and slate
	0812	Operation of gravel and sand pits; mining of clays and kaolin
	0899	Other mining and quarrying n.e.c.
Extraction of non-living resources - Other	0893	Extraction of salt
Tourism and recreation incl. yachting	5510	Hotels and similar accommodation
Off-shore Wind Energy	0000	Exploitation of offshore wind energy for producing electricity

ANNEX V: Common indicator structure

a) Common Indicator: XML elements annotated

Table 12 XML elements of the Common Indicator Structure (MSFD Guidance Document 13)

Common indicator structure		XML Schema (XSD)			
ID	Category and relevant fields	Schema Class	Schema Element	Property	Guidance
Access and use					
1	Conditions applying to access and use	AccessAndUse	ConditionsApplying	Required	Text, URL
Assessment findings					
2	Key assessment	AssessmentFindings	KeyAssessment	Required	Text
3	Key messages	AssessmentFindings	KeyMessage	Required	Text, URL
4	Results and Status	AssessmentFindings	ResultsAndStatus	Required	Text, URL
5	Trend	AssessmentFindings	Trend	Optional	Text, URL
Assessment methods					
6	Indicator Definition	AssessmentMethods	IndicatorDefinition	Required	Text
7	Methodology for indicator calculation	AssessmentMethods	IndicatorMethodology	Required	Text, URL
8	Methodology for monitoring	AssessmentMethods	MonitoringMethodology	Optional	Text, URL
9	Indicator units	AssessmentMethods	IndicatorUnits	Optional	Text, URL
10	Concept and target setting method	AssessmentMethods	ConceptAndTarget	Optional	Text, URL
Assessment purpose					
11	Indicator purpose	AssessmentPurpose	IndicatorPurpose	Required	Text, URL
12	Policy relevance	AssessmentPurpose	PolicyRelevance	Optional	Text, URL
13	Relevant publications (policy, scientific etc)	AssessmentPurpose	RelevantPublications	Optional, Unbounded	Text, URL
14	Policy Targets	AssessmentPurpose	PolicyTargets	Optional	Text
Contact and responsibility					
15	Contributing countries	Contact	ContributingCountries	Optional, Unbounded	ISO 3166-1 alpha-2 Country Code
16	Citation	Contact	Citation	Required	Text, URL

Common indicator structure		XML Schema (XSD)			
ID	Category and relevant fields	Schema Class	Schema Element	Property	Guidance
17	Point of contact	Contact	PointOfContact	Required	Text
Data inputs and outputs					
18	Data sources	DataInputOutput	DataSources	Required	Text, URL, DOI
19	Assessment dataset	DataInputOutput	AssessmentDataset	Required	URL
20	Assessment result	DataInputOutput	AssessmentResult	Required	Text, URL
21	Assessment result- map	DataInputOutput	AssessmentResultMap	Optional	Text, URL
Geographical scope					
22	Assessment/Reporting unit	GeographicalScope	AssessmentReportingUnit	Optional, Unbounded	Text, URL
23	Countries	GeographicalScope	Countries	Required, Unbounded	ISO 3166-1 alpha-2 Country Code
24	Other geographical unit	GeographicalScope	OtherGeographicalUnit	Optional	Text
37	Assessment area (context)		AssessmentArea	Optional	Text
Labelling and classification					
25	DPSIR	LabellingClass	DPSIR	Optional	DPSIR Type
26	MSFD criteria	LabellingClass	MSFDCriteria	Required	Text
27	Indicator title	LabellingClass	IndicatorTitle	Required	Text
28	INSPIRE topics	LabellingClass	INSPIRETheme	Required	Inspire Theme
Quality aspects					
29	Data confidence	QualityAspects	DataConfidence	Required	Text
30	Indicator methodology confidence	QualityAspects	IndicatorConfidence	Optional	Text
31	GES - confidence	QualityAspects	GESConfidence	Optional	Text
Temporal scope					
32	Temporal Coverage	TemporalScope	TemporalCoverage	Required	Date Range
Version control					
33	Last modified date	VersionControl	LastModifiedDate	Optional	Date
34	Published date	VersionControl	PublishedDate	Required	Date
35	Unique reference	VersionControl	UniqueReference	Optional	Text, URL
36	version linkage	VersionControl	VersionLinkage	Optional	URL

b) Mapping between 'Indicators' schema elements and the 'Common Indicator Structure' elements

MSFD reporting schema: Indicators		Common Indicator Structure: relevant field	
Schema class	Schema element	Field Label name	Schema Element name
MarineUnit	MarineUnit	22. Assessment/Reporting unit	AssessmentUnit
Feature	Feature	26. MSFD Criteria	MSFDCriteria
Feature	GEScomponent	26. MSFD Criteria	MSFDCriteria
IndicatorAssessment	IndicatorCode	Not mapped	
IndicatorAssessment	IndicatorTitle	27. Indicator title	IndicatorTitle
IndicatorAssessment	IndicatorSource	16. Citation	Citation
IndicatorAssessment	URL	35. Unique reference	UniqueReference
Datasets	URL	19. Assessment dataset	AssessmentDataset
Datasets	MD_URL	19. Assessment dataset	AssessmentDataset

ANNEX VI: GES assessments to be provided under the ART8_GES schema

GES component	Feature	GES extent unit	Pre-defined elements & lists	Criteria
D1 Biodiversity – [species group]	Each of the species groups	Proportion of species in good status within species group	Species list	D1C1;D1C2;D1C3;D1C4;D1C5
D1 Biodiversity - pelagic habitats	Pelagic broad habitats	Proportion of habitats in good status	Pelagic broad habitat types	D1C6
D1 Biodiversity - pelagic habitats	Other pelagic habitats	Proportion of habitats in good status	Habitats from EUNIS and Habitats Directive	D1C6
D2 Non-indigenous species	Newly-introduced non-indigenous species	Number of newly-introduced species		D2C1
D2 Non-indigenous species	Established non-indigenous species	Not relevant	NIS list	D2C2
D2 Non-indigenous species	Benthic broad habitats	Not relevant	Benthic broad habitat types	D2C3
D2 Non-indigenous species	Pelagic broad habitats	Not relevant	Pelagic broad habitat types	D2C3
D2 Non-indigenous species	Species groups	Not relevant	Species groups	D2C3
D3 Commercial fish and shellfish	Commercially-exploited fish and shellfish	Proportion of populations in good status	Commercial species list	D3C1;D3C2;D3C3
D4 Food webs/D1 Biodiversity - ecosystems	Coastal ecosystems	Not relevant	Trophic guilds	D4C1;D4C2;D4C3;D4C4
D4 Food webs/D1 Biodiversity - ecosystems	Oceanic/deep-sea ecosystems	Not relevant	Trophic guilds	D4C1;D4C2;D4C3;D4C4
D4 Food webs/D1 Biodiversity - ecosystems	Shelf ecosystems	Not relevant	Trophic guilds	D4C1;D4C2;D4C3;D4C4
D5 Eutrophication	Eutrophication	Proportion of area in good status	DIN; TN; DIP; TP	D5C1
D5 Eutrophication	Eutrophication	Proportion of area in good status	Chlorophyll-a	D5C2
D5 Eutrophication	Eutrophication	Proportion of area in good status	Harmful algal bloom species list	D5C3
D5 Eutrophication	Eutrophication	Proportion of area in good status	Transparency	D5C4
D5 Eutrophication	Eutrophication	Proportion of area in good status	Dissolved oxygen	D5C5
D5 Eutrophication	Eutrophication	Proportion of area in good status	Benthic habitats - opportunistic macroalgae	D5C6
D5 Eutrophication	Eutrophication	Proportion of area in good status	Benthic habitats - macrophyte communities	D5C7
D5 Eutrophication	Eutrophication	Proportion of area in good status	Benthic habitats - macrobenthic communities	D5C8

GES component	Feature	GES extent unit	Pre-defined elements & lists	Criteria
D6 Sea-floor integrity/D1 Biodiversity - benthic habitats	Physical loss of the seabed	Not relevant		D6C1
D6 Sea-floor integrity/D1 Biodiversity - benthic habitats	Physical disturbance to the seabed	Not relevant		D6C2
D6 Sea-floor integrity/D1 Biodiversity - benthic habitats	Benthic broad habitats	Proportion of habitats in good status	Benthic broad habitat types	D6C3;D6C4;D6C5
D6 Sea-floor integrity/D1 Biodiversity - benthic habitats	Other benthic habitats	Proportion of habitats in good status	Habitats from EUNIS and Habitats Directive	D6C3;D6C4;D6C5
D7 Hydrographical changes	Hydrographical changes	Not relevant		D7C1
D7 Hydrographical changes	Benthic broad habitats	Not relevant	Benthic broad habitat types	D7C2
D7 Hydrographical changes	Other benthic habitats	Not relevant	Habitats from EUNIS and Habitats Directive	D7C2
D8 Contaminants	Contaminants - non UPBT substances	Proportion of substances in good status	Contaminants list	D8C1
D8 Contaminants	Contaminants - UPBT substances	Proportion of substances in good status	Contaminants list	D8C1
D8 Contaminants	Acute pollution events	Not relevant		D8C3
D8 Contaminants	Benthic broad habitats	Not relevant	Benthic broad habitat types	D8C2;D8C4
D8 Contaminants	Species	Not relevant	Species list	D8C2;D8C4
D9 Contaminants in seafood	Contaminants in seafood	Proportion of substances in good status	Contaminants in Foodstuffs Regulation	D9C1
D10 Marine litter	Litter in the environment	Proportion of litter categories in good status	Marine Litter Categories	D10C1
D10 Marine litter	Micro-litter in the environment	Proportion of litter categories in good status	Marine Litter Categories	D10C2
D10 Marine litter	Litter and micro-litter in species	Proportion of litter categories in good status	Species list	D10C3
D10 Marine litter	Species	Not relevant	Species list	D10C4
D11 Energy, including underwater noise	Impulsive sound in water	Proportion of area in good status		D11C1
D11 Energy, including underwater noise	Continuous low frequency sound	Proportion of area in good status		D11C2