

Proposals for amendments to Regulation No. 63

This informal document was prepared by the expert from the European Commission to complement the proposals in ECE/TRANS/WP.29/GRB/2016/7. It contains additional amendments related to powered cycles. The amendments are related to the definitions and to Annexes 3 and 4.

This document does not represent an official position of the European Commission. It is a tool to explore the views of interested parties. The suggestions contained in this document do not prejudge the form and content of any possible future proposal by the European Commission.

I Proposal

Regulation No. 63 amend to read

Uniform provisions concerning the approval of L₁ category vehicles ~~two-wheeled mopeds~~ with regard to noise sound emission

Contents

	<i>Page</i>
Regulation	
1. Scope	3
2. Definitions	3
3. Application for approval	5
4. Markings	6
5. Approval	6
6. Specifications	7
7. Modification and extension of the approval of the moped vehicle or of the type of exhaust or silencing system(s).....	8
8. Conformity of production.....	9
9. Penalties for non-conformity of production	9
10. Transitional provisions.....	9
11. Production definitively discontinued.....	10
12. Names and addresses of Technical Services responsible for conducting approval tests and of Type Approval Authorities.....	10
Annexes	
1 Communication	11
2 Arrangements of the approval mark	14
3 Methods and instruments for measuring the noise made sound emitted by mopeds L₁ category vehicles	15
4 Maximum sound level limits (new mopeds vehicles)	32
5 Test track specifications	33

1. Scope

This Regulation applies to vehicles of category L₁¹ with regard to **sound emission noise**.

2. Definitions

For the purposes of this Regulation,

- 2.1. "*Approval of a ~~vehicle moped~~*" means the approval of a **moped vehicle** type with regard to **sound emission noise** and the original exhaust system as a technical ~~component~~ **unit** of a two-wheeled type of **vehicle moped**;
- 2.2. "*Moped Vehicle type*" means a category of **vehicles mopeds** which do not differ in such essential respects as:
- 2.2.1. The type of engine (two stroke or four stroke; with reciprocating or rotary pistons; number and capacity of cylinders; number and type of carburettors or injection systems; arrangement of valves; **rated** maximum net power and ~~corresponding~~ **rated** engine speed).
- For rotary piston engines, the cubic capacity should be taken to be double of the volume of the chamber;
- 2.2.2. **Drive train, in particular the number and ratios of gears of the transmission and the final ratio**;
- 2.2.3. The number, type and arrangement of exhaust systems;
- ~~2.2.3.1.3.~~ "*Exhaust or silencing system*" means a complete set of components necessary for limiting the **sound emitted noise** ~~noise made~~ by the engine of the **vehicle moped** and its exhaust
- ~~2.2.3.2.4.~~ "*Original exhaust or silencing system*" means a system of the type fitted to the vehicle on approval or extension of approval. It may be original or a replacement.
- ~~2.2.3.3.5.~~ "*Non-original exhaust or silencing system*" means a system of a type different from that fitted to the vehicle on approval or extension of approval. It may be used only as a replacement exhaust or silencing system.
- 2.6 **"Rated maximum net power"**
- For vehicles with a combustion engine "rated maximum net power" means the rated engine power as defined in ISO 4106:2012.**
- The symbol P_n denotes the numerical value of the rated maximum net power expressed in kW.**
- 2.7 **"Rated engine speed" means the engine speed at which the engine develops its rated maximum net power as stated by the manufacturer².**

¹ As defined in the Consolidated resolution on the Construction of vehicles (R.E.3), document ECE/TRANS/WP.29/78/Rev.2, para.2.

The symbol n_{rated} denotes the rated engine speed expressed in min^{-1} .

~~2.3.~~ "~~Exhaust or silencing system~~" means a complete set of components necessary for limiting the ~~sound emitted~~ noise made by a ~~vehicle~~ moped and its exhaust;

~~2.4.2.8~~ "~~Silencing systems of different types~~" means silencing systems which differ in such essential respects as:

~~2.4.1.2.8.1~~ That their components bear different trade names or marks;

~~2.4.2.2.8.2~~ That the characteristics of the materials constituting a component are different or that the components differ in shape or size;

~~2.4.3.2.8.3~~ That the operating principles of at least one component are different;

~~2.4.4.2.8.4~~ That their components are assembled differently;

~~2.5.2.9~~ "~~Exhaust system component~~" means one of the individual constituent parts which, when assembled, constitute the exhaust system (e.g, exhaust pipes, silencer) and, where applicable, the intake device (air filter).

If the engine is fitted with an intake device (air filter and/or an intake ~~noise~~ **sound** absorber essential in order to ensure conformity with ~~noise~~ **sound** level limits), this device shall be considered to be a component of the same importance as the exhaust system proper, and be included in the list referred to in paragraph 3.2.2. below and carry the markings prescribed in paragraph 4.1. below.

2.10 Reference mass

2.10.1 The reference mass of an L_1 category vehicle shall be determined by measuring the mass of the unladen vehicle ready for normal use and shall include the mass of:

(a) liquids;

(b) standard equipment in accordance with the manufacturer's specifications;

(c) 'fuel' in the fuel tanks that shall be filled to at least 90 per cent of their capacities.

For the purposes of this point:

(i) if a vehicle is propelled with a 'liquid fuel' this shall be considered as 'fuel';

(ii) if a vehicle is propelled with a liquid 'fuel/oil mixture':

- if fuel to propel the vehicle and lubrication oil are pre-mixed then this 'pre-mixture' shall be considered as 'fuel',

- if fuel to propel the vehicle and lubrication oil are stored separately then only 'fuel' propelling the vehicle shall be considered as 'fuel'; or

² If the rated maximum net power is reached at several engine speeds, the rated engine speed is used in this Regulation as the highest engine speed at which the rated maximum net power is reached.

(iii) if a vehicle is propelled by a gaseous fuel, a liquefied gaseous fuel or is running on compressed air, the mass of 'fuel' in the gaseous fuel tanks may be set to 0 kg;

(d) the bodywork, the cabin, the doors;

(e) the glazing, the coupling, the spare wheels as well as the tools.,

2.10.2. The reference mass of an L-category vehicle shall exclude the mass of:

(a) the machines or equipment installed on the load platform area;

(b) in the case of mono-fuel, bi-fuel or multi-fuel vehicles, a gaseous fuel system as well as storage tanks for gaseous fuel; and

(c) in the case of pre-compressed air propulsion, storage tanks to store compressed air.

2.11 Test mass

The test mass is the reference mass plus the combined mass of the driver and test equipment.

The combined mass of the driver and test equipment used on the vehicle shall not be more than 90 kg nor less than 70 kg. Weights shall be placed on the vehicle, if the 70 kg minimum is not reached.

2.12 Maximum vehicle speed

The maximum vehicle speed is the maximum design vehicle speed measured according to ISO 7116:2011.

2.13 L1-A – Powered cycle

"Category L1-A or powered cycle" means a cycle designed to pedal equipped with an auxiliary propulsion unit, other than auxiliary electric propulsion, with the primary aim to aid pedalling and having an output of the auxiliary propulsion unit which is cut off at a vehicle speed ≤ 25 km/h and with 250 W \leq maximum continuous or rated net power ≤ 1000 W.

2.14 L1-B - vehicle

"Category L1-B or two-wheeled moped" means a power driven two-wheeled vehicle with a maximum design vehicle speed ≤ 50 km/h or ≤ 45 km/h at the choice of the contracting party and with a maximum continuous rated or net power ≤ 4000 W.

Comment: The above text is copied from EPPR-10-04 and introduced in this paragraph, as discussed during the 64th GRB.

Justification: Distinction of L1-A and L1-B under L1-category vehicles.

3. Application for approval

3.1. The application for approval of a ~~moped~~ **vehicle** type with regard to ~~noise made~~ **the sound emitted** by ~~vehicles~~ **mopeds** shall be submitted by its manufacturer or by his duly accredited representative.

- 3.2. It shall be accompanied by the undermentioned documents in triplicate and the following particulars:
 - 3.2.1. A description of the ~~moped~~ **vehicle** type with regard to the items mentioned in paragraph 2.2. above. The numbers and/or symbols identifying the engine type and the ~~moped~~ **vehicle** type shall be specified;
 - 3.2.2. A list of the components, duly identified, constituting the exhaust or silencing system;
 - 3.2.3. A drawing of the assembled exhaust or silencing system and an indication of its position on the ~~vehicle~~ **moped**;
 - 3.2.4. Detailed drawings of each component to enable it to be easily located and identified, and a specification of the materials used.
- 3.3. At the request of the technical service responsible for conducting approval tests, the ~~moped~~ **vehicle** manufacturer shall, in addition, submit a sample of the exhaust or silencing system.
- 3.4. A ~~moped~~ **vehicle** representative of the ~~moped~~ **vehicle** type, to be approved shall be submitted to the technical service responsible for conducting approval tests.

4. Markings

- 4.1. The components of the exhaust or silencing system shall bear at least the following identifications:
 - 4.1.1. The trade name or mark of the manufacturer of the exhaust or silencing system and of its components;
 - 4.1.2. The trade description given by the manufacturer.
 - 4.1.3. The identifying part numbers; and
 - 4.1.4. For all original silencers, the "E" mark followed by the identification of the country which granted the component type approval.
 - 4.1.5. Any packing of original replacement exhaust or silencing systems shall be marked legibly with the words "original part" and the make and type references integrated together with the "E" mark and also the reference to the country of origin.
 - 4.1.6. Such markings shall be indelible, clearly legible and visible, in the position on which it is to be located on the ~~vehicle~~ **moped**.

5. Approval

- 5.1. If the ~~moped~~ **vehicle** submitted for approval pursuant to paragraph 3 of this Regulation meets the requirements of paragraphs 6. and 7. below, approval of that ~~moped~~ **vehicle** type with regard to the **sound emission** ~~noise~~ shall be granted.
- 5.2. An approval number shall be assigned to each type approved. Its first two digits shall indicate the series of amendments (at present 02) incorporating the most recent major technical amendments made to the Regulation at the time of issue of the approval. The same Contracting Party may not assign the

same number to the same ~~moped vehicle~~ type equipped with another type of exhaust or silencing system, or to another ~~moped vehicle~~ type.

- 5.3. Notice of approval or of refusal of approval of a ~~moped vehicle~~ type pursuant to this Regulation shall be communicated to the Parties to the Agreement which apply this Regulation, by means of a form conforming to the model in Annex 1 to this Regulation and of drawings of the exhaust or silencing system supplied by the applicant for approval, in a format not exceeding A4 (210 x 297 mm) or folded to that format and on an appropriate scale.
- 5.4. There shall be affixed, conspicuously and in a readily accessible place specified on the approval form, to every ~~moped vehicle~~ conforming to a ~~moped vehicle~~ type approved under this Regulation an international approval mark consisting of:
 - 5.4.1. A circle surrounding the letter "E" followed by the distinguishing number of the country which has granted approval;³
 - 5.4.2. The number of this Regulation, followed by the letter "R", a dash and the approval number to the right of the circle prescribed in paragraph 5.4.1. above.
- 5.5. If the ~~moped vehicle~~ conforms to a ~~moped vehicle~~ type approved, under one or more Regulations annexed to the Agreement, in the country which has granted approval under this Regulation, the symbol prescribed in paragraph 5.4.1. above need not be repeated; in such a case the Regulation and approval numbers and the additional symbols of all the Regulations under which approval has been granted in the country which has granted approval under this Regulation shall be placed in vertical columns to the right of the symbol prescribed in paragraph 5.4.1. above.
- 5.6. The approval mark shall be clearly legible and be indelible.
- 5.7. The approval mark shall be placed close to or on the ~~moped vehicle~~ data plate.
- 5.8. Annex 2 to this Regulation gives arrangements of approval marks.

6. Specifications

- 6.1 General specifications
 - 6.1.1. The ~~moped vehicle~~, its engine and its exhaust or silencing system shall be so designed, constructed and assembled as to enable the ~~moped vehicle~~, in normal use, despite the vibration to which it may be subjected, to comply with the provisions of this Regulation.
 - 6.1.2. The exhaust or silencing system shall be so designed, constructed and assembled as to be able to resist the corrosive action to which it is exposed.
 - 6.1.3. The following information shall be provided on the ~~moped vehicle~~ in an easily accessible but not necessarily immediately visible location:
 - (a) The manufacturer's name;

³ The distinguish numbers of the Contracting Parties to the 1958 Agreement are reproduced in Annex 3 to Consolidated Resolution on the Construction of Vehicles (R.E.3), document ECE/TRANS/WP.29/78/Rev.2/Amend.3.

(b) The target engine speed and the final result of the stationary test as defined in paragraph 3.2. of Annex 3 to this Regulation.

6.2. Specifications regarding sound levels

6.2.1. Methods of measurement

6.2.1.1. The ~~noise made~~ **sound emitted** by the ~~moped vehicle~~ type submitted for approval shall be measured by the ~~two~~ method(s) described in Annex 3 to this Regulation for the ~~moped vehicle~~ in motion and ~~for the moped~~ when stationary.⁴ In the case of a ~~moped vehicle~~ with an internal combustion engine that does not operate when the ~~vehicle moped~~ is stationary, the emitted ~~sound noise~~ shall only be measured in motion.

6.2.1.2. The ~~two~~ value(s) measured in accordance with the provisions of paragraph 6.2.1.1. above shall be entered in the test report and on a form conforming to the model in Annex 1 to this Regulation.

6.2.1.3. The sound level measured by the method described in paragraph 3.1. of Annex 3 to this Regulation when the ~~moped vehicle~~ is in motion shall not exceed the limits prescribed (for new ~~mopeds vehicles~~ and new exhaust or silencing systems) in Annex 4 to this Regulation for the category to which the ~~moped vehicle~~ belongs.

6.3. ~~Additional requirements prescriptions related to tamperability and manually adjustable multi-mode exhaust or silencing systems~~

6.3.1. **Tampering protection provisions**

All exhaust or silencing systems shall be constructed in a way that does not ~~easily~~ permit removal of baffles, exit-cones and other parts whose primary function is as part of the silencing/expansion chambers. Where incorporation of such a part is unavoidable, its method of attachment shall be such that removal is not ~~easily~~ facilitated (e.g. with conventional threaded fixings) and ~~should~~ **shall** also be attached so that removal causes permanent/irrecoverable damage to the assembly.

6.3.2. **Multi-mode exhaust or silencing systems**

Exhaust or silencing systems with multiple, manually **or electronically** adjustable, **rider selectable** operating modes shall meet all requirements in all operating modes. The reported ~~noise sound~~ levels shall be those resulting from the mode with the highest ~~noise sound~~ levels.

6.3.3. **Prohibition of defeat devices**

The ~~moped vehicle~~ manufacturer shall not intentionally alter, adjust, or introduce any device or procedure solely for the purpose of fulfilling the ~~noise sound~~ emission requirements of this Regulation, which will not be operational during typical on-road operation.

⁴ A test is made on a stationary ~~moped vehicle~~ in order to provide a reference value for administrations which use this method to check ~~mopeds vehicles~~ in use.

7. Modifications and extension of the approval of the moped vehicle type or of the type of exhaust or silencing system(s)

- 7.1. Every modification of the ~~moped vehicle~~ type or of the exhaust or silencing system shall be notified to the Type Approval Authority which approved the ~~moped vehicle~~ type. The said Authority may then either:
 - 7.1.1. Consider that the modifications made are unlikely to have appreciable adverse effects; or
 - 7.1.2. Require a further test report from the Technical Service responsible for conducting the tests.
- 7.2. Confirmation or refusal of approval, specifying the alterations, shall be communicated by the procedure specified in paragraph 5.3. of this Regulation to the Parties to the Agreement which apply this Regulation.
- 7.3. The Type Approval Authority which issued the approval extension shall assign a serial number to the extension and shall so notify the other Parties to the 1958 Agreement applying this Regulation, by means of a communication form conforming to the model in Annex 1 to this Regulation.

8. Conformity of production

The conformity of production procedures shall comply with those set out in the Agreement, Appendix 2 (E/ECE/324-E/ECE/TRANS/505/Rev.2), with the following requirements:

- 8.1. Every ~~moped vehicle~~ bearing an approval mark as prescribed under this Regulation shall conform to the ~~moped vehicle~~ type approved, be fitted with the exhaust or silencing system with which it was approved and satisfy the requirements of paragraph 6. above.
- 8.2. In order to verify conformity as prescribed in paragraph 8.1. above, a ~~moped vehicle~~, bearing the approval mark required by this Regulation, shall be taken from the series. Production shall be deemed to conform to the requirements of this Regulation if the level measured by the method described in paragraph 3.1. of Annex 3 to this Regulation does not exceed by more than 3 dB(A) the value measured during type approval nor by more than 1 dB(A) the limits prescribed in Annex 4 to this Regulation.

9. Penalties for non-conformity of production

- 9.1. The approval granted in respect of a ~~moped vehicle~~ type pursuant to this Regulation may be withdrawn if the requirements laid down in paragraph 8.1. above are not complied with, or if the ~~moped vehicle~~ has failed to pass the tests provided for in paragraph 8.2. above.
- 9.2. If a Party to the Agreement which applies this Regulation withdraws an approval it has previously granted, it shall forthwith so notify the other Parties to the 1958 Agreement applying this Regulation, by means of a communication form conforming to the model in Annex 1 to this Regulation.

10. Transitional provisions

- 10.1 As from the official date of entry into force of the 02 series of amendments, no Contracting Party applying this Regulation shall refuse to grant or refuse to accept type approvals under this Regulation as amended by the 02 series of amendments.
- 10.2 As from 24 months after the date of entry into force of the 02 series of amendments, Contracting Parties applying this Regulation shall grant type approvals only if the vehicle type to be approved meets the requirements of this Regulation as amended by the 02 series of amendments.
- 10.3 Contracting Parties applying this Regulation shall not refuse to grant extensions of type approvals for existing types which have been granted according to the preceding series of amendments to this Regulation.
- 10.4 Until 24 months after the date of entry into force of the 02 series of amendments to this Regulation, no Contracting Party applying this Regulation shall refuse national or regional type approval of a vehicle type-approved to the preceding series of amendments to this Regulation.
- 10.5 As from 24 months after the date of entry into force of the 02 series of amendments to this Regulation, Contracting Parties applying this Regulation shall not be obliged to accept, for the purpose of national or regional type approval, a vehicle type approved to the preceding series of amendments to this Regulation.
- 10.6 Notwithstanding the transitional provisions above, Contracting Parties whose application of this Regulation comes into force after the date of entry into force of the most recent series of amendments are not obliged to accept type approvals which were granted in accordance with any of the preceding series of amendments to this Regulation are only obliged to accept type approval granted in accordance with the 02 series of amendments.
- 10.7 **As from the official date of entry into force of Supplement 1 to the 02 series of amendments, no Contracting Party applying this Regulation shall refuse to grant or refuse to accept type approval according to Supplement 1 to 02 series of amendments to this Regulation.**
- 10.8 **As from 60 months after the date of entry into force of Supplement 1 to the 02 series of amendments to this Regulation, Contracting Parties applying this Regulation shall grant type approvals only if the vehicle type to be approved meets the requirements of this Regulation as amended by Supplement 1 to the 02 series of amendments to this Regulation."**

11. Production definitively discontinued

If the holder of the approval completely ceases production of a type of ~~moped~~ **vehicle** approved in accordance with this Regulation, he shall so inform the Type Approval Authority which granted the approval which in turn shall notify the other Parties to the 1958 Agreement applying this Regulation, by means of a copy of the communication form conforming to the model in Annex 1 to this Regulation.

12. Names and addresses of Technical Services conducting approval tests and of Type Approval Authorities

The Parties to the Agreement which apply this Regulation shall communicate to the United Nations Secretariat the names and addresses of the Technical Services responsible for conducting approval tests and of the Type Approval Authorities which grant approval and to which forms certifying approval or extension or refusal or withdrawal of approval or production definitely discontinued, issued in other countries, are to be sent.

Annex 1

Communication

(maximum format: A4 (210 x 297 mm))

issued by: Name of administration:

.....
.....
.....

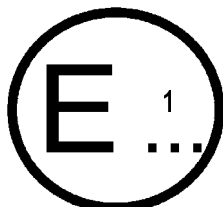

concerning:² Approval granted
Approval extended
Approval refused
Approval withdrawn
Production definitively discontinued

of a vehicle type with regard to its ~~noise~~ **sound** emission pursuant to Regulation No. 63

Approval No..... Extension No

1. Trade name or mark of the ~~moped~~ **vehicle**
2. ~~Moped~~ **Vehicle** type
3. Variant(s) (if applicable):
4. Version(s) (if applicable):.....
5. Name and address of manufacturer:
6. Name and address of manufacturer's representative (if applicable):
7. Type(s) of original exhaust system(s):.....
8. Type(s) of intake device(s) (if required in order to ensure conformity with ~~noise~~ **sound** level limits):
9. Type of engine:³
10. Cycles: 2-stroke or 4-stroke (if applicable)²
11. Cylinder capacity:**cm³**
- 11.1. Bore:**mm**
- 11.2. Stroke:.....**mm**
12. **Rated maximum net** ~~Engine~~ power (state how measured):**kW**

¹ Distinguishing number of the country which has granted/refused/withdrawn approval (see approval provisions in the Regulation).

² Strike out what does not apply.

³ If a non-conventional engine is used, this should be stated.

13. **Rated** engine speed at which maximum power is developed: min⁻¹
14. ~~Number of gears~~ Transmission:
- 14.1 Make**.....
- 14.2 Type (manual, automatic, CVT)**.....
- 14.3 Number of gears:**
- 14.14. Gears used:
- 14.25. Final drive ratio(s):
15. Type and dimensions of tyres:
16. Maximum permissible gross weight: kg
17. Maximum design **vehicle** speed (as indicated by the manufacturer): km/h
18. For stationary ~~moped~~ **vehicle** test: location and orientation of the microphone (by reference to diagrams in Annex 3 to this Regulation)
19. Sound levels:.....
- ~~Moped~~ **Vehicle** in motion:..... dB(A)
- At approach **vehicle** speed (Line A-A') of: km/h,
- Rotation speed of the engine: min⁻¹
- ~~Moped~~ **Vehicle** stationary: dB(A)
- With engine running at: min⁻¹
- ~~20. Deviations in calibration of sound level meter:~~
- 20. In use compliance reference data**
- 20.1. Gear (i) for vehicles with manual transmission:**
- 20.2. Vehicle speed at the beginning of the period of acceleration (average of 3 runs) for gear (i):** km/h
- 20.3. Sound pressure level $L_{wot(i)}$:** dB(A)
21. ~~Moped~~ **Vehicle** submitted for approval on:
22. Technical Service responsible for conducting approval tests:
23. Date of report issued by that Service:
24. Number of report issued by that Service:
25. Approval granted/refused/extended/withdrawn²
26. Position of approval mark on the ~~moped~~ **vehicle**:
27. Place:
28. Date:
29. Signature:
30. The following documents, bearing the approval number shown above, are annexed to this communication:
- (a) Drawings, diagrams and plans of the engine and of the exhaust or silencing system;

- (b) Photographs of the engine and of the exhaust or silencing system;
- (c) List of duly identified components constituting the exhaust or silencing system.

Annex 2

Arrangements of the approval mark

Model A
(See paragraph 5.4. of this Regulation)

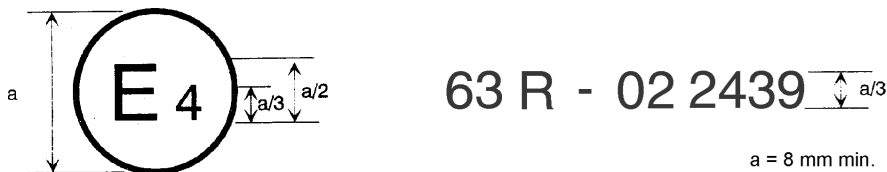

The above approval mark affixed to a vehicle shows that the vehicle type concerned has, with regard to its ~~noise~~ **sound** emission, been approved in the Netherlands (E 4) pursuant to Regulation No. 63 under approval No. 022439. The approval number indicates that the approval was granted according to the requirements of Regulation No. 63 as amended by the 02 series of amendments.

Model B
(See paragraph 5.5. of this Regulation)

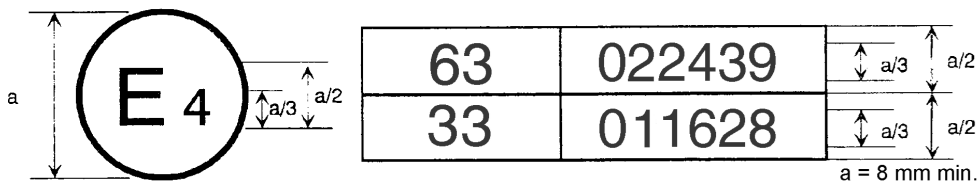

The above approval mark affixed to a vehicle shows that the vehicle type concerned has been approved in the Netherlands (E 4) pursuant to Regulation Nos. 63 and 33.¹ The approval numbers indicate that, at the dates when the respective approvals were given, Regulation No. 63 included the 02 series of amendments and Regulation No. 33 has also been amended by the 01 series of amendments.

¹ The second number is given merely as an example.

Annex 3

Methods and instruments for measuring the noise made sound emitted by mopeds L₁ category vehicles

1. Measuring instruments

1.1. Acoustic measurements

1.1.1. General

The apparatus used for measuring the sound pressure level shall be a sound level meter or equivalent measuring system meeting the requirements of Class 1 instruments (inclusive of the recommended windscreen, if used). These requirements are described in IEC 61672 1:2002. Measurements shall be carried out using the time weighting "F" of the acoustic measuring instrument and the "A" frequency weighting curve also described in IEC 61672-1:2002. When using a system that includes periodic monitoring of the A-weighted sound pressure level, a reading should be made at a time interval not greater than 30 ms. The instruments shall be maintained and calibrated in accordance with the instructions of the instrument manufacturer.

1.1.2. Calibration

At the beginning and at the end of every measurement session, the entire acoustic measuring system shall be checked by means of a sound calibrator that fulfils the requirements of Class 1 sound calibrators according to IEC 60942:2003. Without any further adjustment, the difference between the readings shall be less than or equal to 0.5 dB(A). If this value is exceeded, the results of the measurements obtained after the previous satisfactory check shall be discarded.

1.1.3. Compliance with requirements

Compliance of the sound calibrator with the requirements of IEC 60942:2003 shall be verified once a year. Compliance of the instrumentation system with the requirements of IEC 61672-1:2002 shall be verified at least every 2 years. All compliance testing shall be conducted by a laboratory which is authorized to perform calibrations traceable to the appropriate standards.

1.2. Instrumentation for speed measurements

The rotational speed of the engine shall be measured with an instrument meeting specification limits of at least ± 2 per cent or better at the engine speeds required for the measurements being performed.

The road speed of the vehicle shall be measured with instruments meeting specification limits of at least ± 0.5 km/h when using continuous measuring devices. If testing uses independent measurements of **vehicle** speed, this instrumentation shall meet specification limits of at least ± 0.2 km/h.¹

¹ Independent measurements of **vehicle** speed are when two or more separate devices will determine the values of vAA' and vBB'. A continuous measuring device such as radar will determine all required **vehicle** speed information with one device.

- 1.5. Meteorological instrumentation
- The meteorological instrumentation used to monitor the environmental conditions during the test shall meet the following specifications:
- ±1 °C or less for a temperature measuring device;
 - ±1.0 m/s for a wind speed measuring device;
 - ±5 hPa for a barometric pressure measuring device;
 - ±5 per cent for a relative humidity measuring device.
2. Conditions of measurement
- 2.1. **Test site, weather conditions and background noise correction**
- 2.1.1. **Test site**
- The test site shall consist of a central acceleration track surrounded by a substantially level test area. The test track shall be level; the track surface shall be dry and so designed that rolling ~~noise~~ **sound** remains low.
- On the test site, free sound field conditions shall be maintained to within ±1 dB between the sound source placed in the middle of the acceleration section and the microphone. This condition shall be deemed to be met if there are no large sound reflecting objects such as hedges, rocks, bridges or buildings within 50 m of the centre of the acceleration section.
- No obstacle likely to affect the sound field shall be close to the microphone and no one shall come between the microphone and the sound source. The observer taking the measurements shall take up position so as to avoid influencing the metre readings.
- ~~2.1.2. The surface of the test track shall conform to the requirements of Annex 5 to this Regulation.~~ **The surface of the test track shall conform to the requirements of Annex 5 to this Regulation or be in accordance to ISO 10844:2014. After the end of the period indicated in paragraph 10.8 of this Regulation only ISO 10844:2014 shall be used as reference.**
- 2.1.32. **Miscellaneous Weather conditions and background noise correction**
- Measurements shall not be made in poor weather conditions. The tests shall not be carried out if the wind speed, including gusts, exceeds 5 m/s during the sound measurement interval.
- For measurement purposes, the weighted sound-level (A) of sound sources **other than** on the test vehicle and the sound-level produced by the effect of the wind shall be at least 10 dB(A) below the ~~noise~~ **sound** level produced by the vehicle. The microphone may be fitted with a suitable wind guard, provided that its influence on the sensitivity and directional characteristics of the microphone are taken into account.
- If the difference between ambient **noise** and measured ~~noise~~ **sound** levels is between 10 and ~~16~~ **15** dB(A), ~~the appropriate figure shall be subtracted from the value recorded by the sound level meter, in accordance with the following graph: 15 dB(A),~~ in order to calculate the test result, the appropriate correction shall be subtracted from the readings on the sound level meter, as given in Table 1.

Table 1
Correction applied to individual measured test value

Background sound pressure level difference to measured sound pressure level, in dB	10	11	12	13	14	≥ 15
Correction, in dB(A)	0.5	0.4	0.3	0.2	0.1	0.0

2.2. ~~Moped~~ **Condition of the vehicle**

2.2.1 **General condition**

Before the measurements are started, the engine shall be brought to its normal operating conditions as regards:

- **Temperatures;**
- **Tuning;**
- **Fuel;**
- **Sparking plugs, carburettor(s), etc., (as appropriate).**

If the vehicle is fitted with fans with an automatic actuating mechanism, this system shall not be interfered with during the sound measurements.

If the vehicle is equipped with devices which are not necessary for its propulsion, but which are used whilst the vehicle is in normal service on the road, those devices shall be in operation in accordance with the specifications of the manufacturer.

In the case of compressed air engines, the normal operating conditions, which do not fall under the above mentioned ones in this paragraph, shall be agreed between the manufacturer and the type-approval authority and shall be annexed to the manufacturer's application for type-approval in accordance with this Regulation.

Justification: including the compressed air engine conditions for the sound level measurement

2.2.2. **Test mass and tyre selection**

2.2.2.1. ~~The combined mass of the driver and test equipment used on the moped shall not be more than 90 kg nor less than 70 kg. Weights shall be placed on the moped if the 70 kg minimum is not reached. While measurements are being taken, the moped shall be equipped as for normal road use (with coolant, lubricants, fuel, tool kit, spare wheel and driver). The vehicle shall be tested with its test mass as defined in paragraph 2.9 of this Regulation.~~

2.2.2.2. **Tyre selection and condition**

The tyres shall be appropriate for the ~~moped~~ **vehicle** and shall be inflated to the pressure recommended by the ~~moped~~ **vehicle** manufacturer for the test mass of the ~~moped~~ **vehicle**.

The tyres shall be selected by the ~~moped~~ **vehicle** manufacturer and correspond to one of the tyre sizes and types designated for the ~~moped~~ **vehicle** by the ~~moped~~ **vehicle** manufacturer. The minimum tread depth shall be at least 80 per cent of the full tread depth.

~~2.2.3. Before the measurements are started, the engine shall be brought to its normal operating conditions as regards:~~

~~2.2.3.1. Temperatures;~~

~~2.2.3.2. Tuning;~~

~~2.2.3.3. Fuel;~~

~~2.2.3.4. Sparking plugs, carburettor(s), etc., (as appropriate).~~

~~2.2.4. If the moped is equipped with devices which are not necessary for its propulsion, but which are used whilst the moped is in normal service on the road, those devices shall be in operation in accordance with the specifications of the manufacturer.~~

3. Methods of testing

3.1. Measurement of ~~noise of mopeds~~ **the sound emission of the vehicle** in motion

3.1.1. ~~General conditions of test~~ **Test arrangement and microphone positions**

3.1.1.1. **The test arrangement is shown in figure 1.**

Figure 1: Measuring positions for vehicles in motion

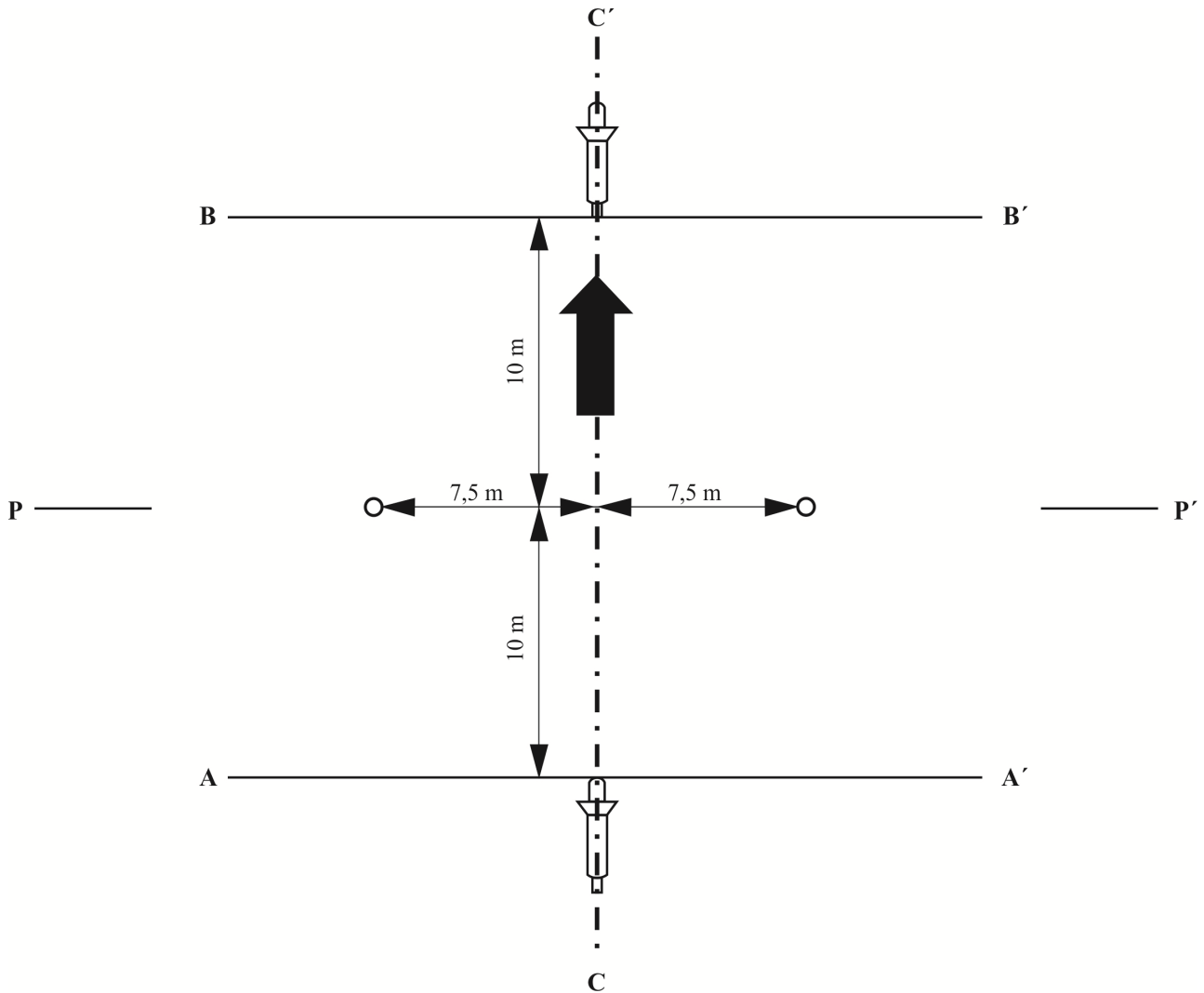

Two lines, AA' and BB', parallel to the microphone line PP' and situated respectively 10 m forward and 10 m rearward of that line shall be marked out on the test track.

~~At least two measurements shall be made on each side of the moped.~~

~~Preliminary measurements may be made for adjustment purposes, but shall be disregarded.~~

3.1.1.2. The distance of the microphone positions from the line CC', on the microphone line PP', perpendicular to the reference line CC' on the test track (see ~~appendix~~, Figure 1), shall be 7.5 ± 0.05 m.

The microphones shall be located 1.2 ± 0.02 m above the ground level. The reference direction for free-field conditions (see IEC 61672-1:2002) shall be horizontal and directed perpendicularly towards the path of the ~~moped~~ **vehicle** line CC'.

~~3.1.1.3. Two lines, AA' and BB', parallel to the microphone line PP' and situated respectively 10 m forward and 10 m rearward of that line shall be marked out on the test track.~~

3.1.2 Acceleration test execution, approach vehicle speed and gear use

3.1.2.1 Acceleration test execution

The ~~moped vehicle~~ shall approach line AA' at an initial steady speed as specified below. When the front of the ~~moped vehicle~~ reaches line AA' the ~~accelerator control~~~~throttle~~ shall be fully opened as quickly as practically possible and kept in that position until the rear of the ~~moped vehicle~~ reaches line BB'; the ~~accelerator control~~ ~~throttle~~ shall then be returned as quickly as possible to the idle position.

Justification: The more general term of “accelerator control” introduced to cover compressed air engines without “throttle” as well (e.g. compressed air engines).

For all measurements, the ~~moped vehicle~~ shall be driven in a straight line along the test track in such a way that the track of the median longitudinal plane of the ~~moped vehicle~~ is as close as possible to the line CC'.

3.1.2.2 Approach vehicle speed

~~3.1.1.4. The maximum sound value recorded at each measurement shall constitute the result of the measurement. The measurements shall be considered valid if the difference between the two consecutive measurements on the same side of the moped vehicle is not more than 2 dB(A).~~

~~3.1.2. Determination of the approach speed~~

~~3.1.2.1. Approach speed~~

The ~~moped vehicle~~ shall approach the line AA' at a steady **vehicle** speed equal to its maximum **vehicle** speed **as defined in paragraph 2.12 of this Regulation**, if the latter is below or equal to 30 km/h. If the maximum **vehicle** speed is above 30 km/h, the vehicle shall approach AA' at a steady speed of 30 km/h.

3.1.2.3 Gear use

~~3.1.2.2. If the moped vehicle is fitted with a manually operated gearbox, the highest gear shall be selected which enables it to pass over the line AA' with an engine speed above or equal to one half the engine speed at which the engine produces its maximum power 50 per cent of rated engine speed as defined in paragraph 2.7 of this Regulation.~~

~~3.1.2.3. If the moped vehicle is fitted with automatic transmission, it shall be driven at the vehicle speeds indicated in 3.1.2.1. 3.1.2.2. above.~~

3.1.3 Sound level determination

The maximum sound level recorded at each side of the vehicle shall be reduced by 1 dB(A) to account for measurement inaccuracy and mathematically rounded to the nearest first decimal place (e.g. XX.X). These values constitute the results of the measurement.

The measurement will be invalid if an abnormal discrepancy is recorded between the peak value and the general sound level.

At least two valid measurements shall be made on each side of the vehicle.

The measurements shall be considered valid if the difference between the results of the two consecutive measurements on the same side of the vehicle is not more than 2 dB(A).

Preliminary measurements may be made for adjustment purposes, but shall be disregarded for the determination of the measurement results.

3.1.4 Calculation of the final test result

The final test result is the average of the four test results rounded off to the nearest whole decibel. If the figure following the decimal point is between 0 and 4, the total is rounded down and if it is between 5 and 9, it is rounded up.

3.2. Measurement of ~~noise~~ the sound emitted by stationary ~~mopeds~~ **vehicles (conditions and method of measurement for testing vehicles ~~in service in use~~).**

In addition, in order to facilitate subsequent testing of ~~mopeds~~ **vehicles in service in use**, the sound pressure level shall be measured close to the outlet of the exhaust (silencing) system, in accordance with the following requirements, and the reading shall be recorded in the test report prepared for the issue of the document referred to in Annex 1 to this Regulation.

The measurements shall be made using a precision sound level metre conforming to the requirements of paragraph 1 of Annex 3 to this Regulation.

3.2.1. Test site - local conditions (~~see Figure 2~~)

3.2.1.1. Measurements shall be made on a stationary ~~moped~~ **vehicle in an area which does not present a great deal of disturbance to the sound field.**

3.2.1.2. Every open space shall be considered as a suitable test site if it consists of a flat area covered with concrete, asphalt or some other hard material having a high reflective capacity, excluding compressed or other earth surfaces, in which one can trace a rectangle whose sides are at least 3 m from the extremities of the ~~moped~~ **vehicle and inside which there is no noticeable obstacle; in particular, the ~~moped~~ **vehicle** shall not be positioned at a distance of less than 1 m from a pavement edge when the exhaust ~~sound~~ **noise** is measured.**

3.2.1.3. Nobody shall be in the measurement area, except the observer and the driver, whose presence shall have no influence on the meter reading.

3.2.2. Disturbance noise and wind interference

The ambient noise levels at each measuring point shall be at least 10 dB(A) below the levels measured during the tests at the same points.

3.2.3. Measuring method

3.2.3.1. Nature and number of measurements

The maximum sound level expressed in A-weighted decibels (dB(A)) shall be measured during the period of operation laid down in paragraph 3.2.3.3.2.1. below.

At least three measurements shall be taken at each measuring point.

3.2.3.2. Position and preparation of the ~~moped~~ **vehicle**

Before the measurements are started, the ~~moped~~ engine of the vehicle shall be brought to its normal operating temperature, if it is an internal combustion engine, or to its normal operating condition, if it is a compressed air engine. If the ~~moped~~ vehicle is equipped with automatic fans, no adjustment shall be made to them during the measurement of the ~~noise~~ sound level.

Justification: introduction of operating condition to cover compressed air engines.

While measurements are being made, the gear lever shall be in neutral. If the transmission cannot be disconnected, the drive wheel of the ~~moped~~ vehicle should be allowed to run under no-load conditions by, for example, placing the ~~moped~~ vehicle on its stand.

3.2.3.3. Measuring of ~~noise~~ sound in proximity to the exhaust

3.2.3.3.1. Position of the microphone (see figure 2)

The microphone shall be located at a distance of 0.5 ± 0.01 m from the reference point of the exhaust pipe defined in ~~figure 4~~ **figure 3** and at an angle of $45^\circ \pm 5^\circ$ to the vertical plane containing the flow axis of the pipe termination. The microphone shall be at the height of the reference point, but not less than 0.2 m from the ground surface. The reference axis of the microphone shall lie in a plane parallel to the ground surface and shall be directed towards the reference point on the exhaust outlet.

The reference point shall be the highest point satisfying the following conditions:

- (a) The reference point shall be at the end of the exhaust pipe;
- (b) The reference point shall be on the vertical plane containing the exhaust outlet centre and the flow axis of the exhaust pipe termination.

If two microphone positions are possible, the location farthest laterally from the ~~moped~~ vehicle longitudinal centreline shall be used. If the flow axis of the exhaust outlet pipe is at $90^\circ \pm 5^\circ$ to the ~~moped~~ vehicle longitudinal centreline, the microphone shall be located at the point that is the furthest from the engine.

If a ~~moped~~ vehicle has two or more exhaust outlets spaced less than 0.3 m apart and connected to a single silencer, only one measurement shall be made.

The microphone shall be located relative to the outlet the farthest from the ~~moped's~~ **vehicle's** longitudinal centreline, or, when such outlet does not exist, to the outlet that is highest above the ground.

For ~~mopeds~~ **vehicles** having an exhaust provided with outlets spaced more than 0.3 m apart, one measurement is made for each outlet as if it were the only one, and the highest sound pressure level shall be noted. For the purpose of roadside checking, the reference point may be moved to the outer surface of the ~~moped~~ **vehicle** body.

Figure 2: Measuring positions for the measurement of sound of the stationary vehicles

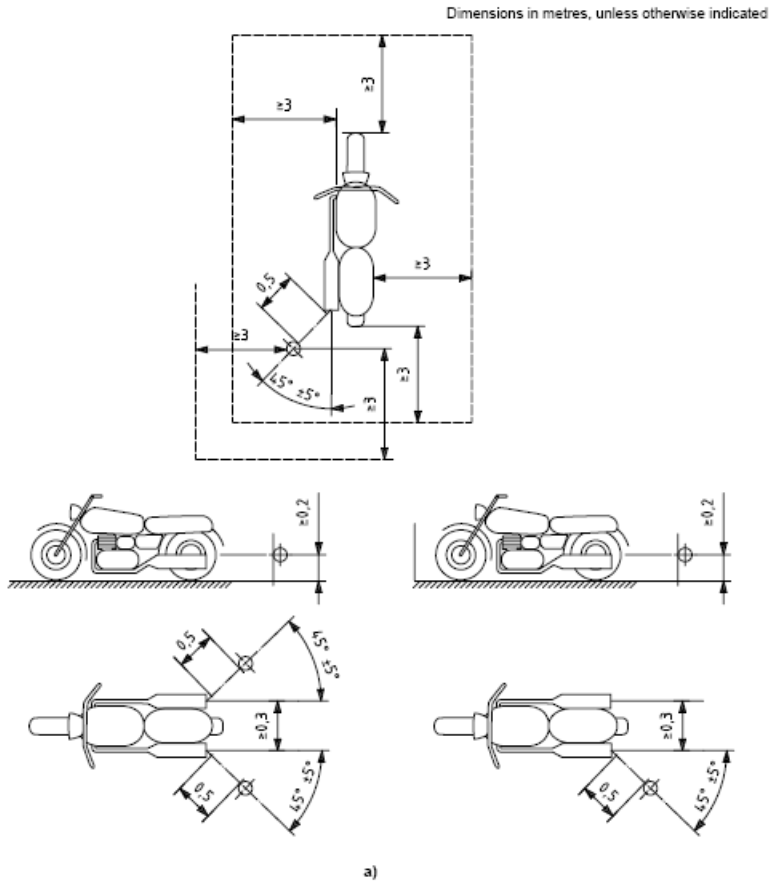
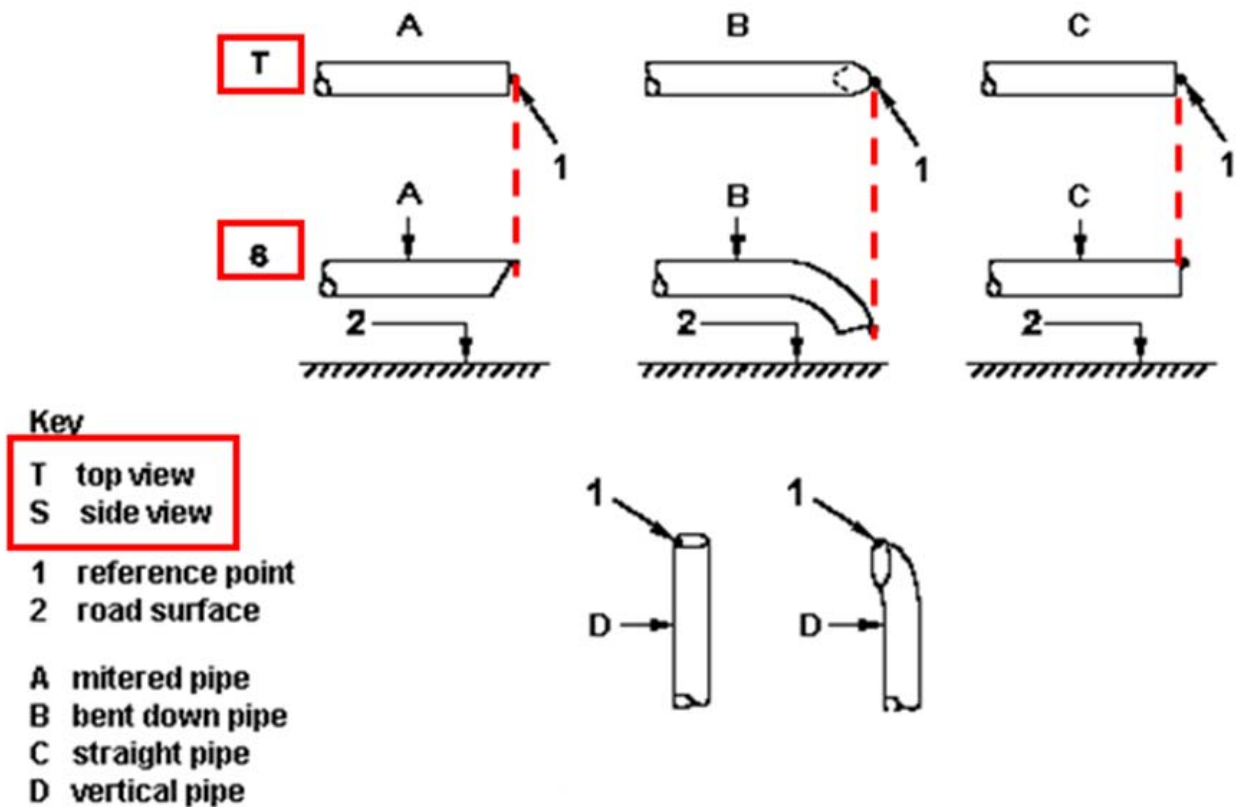

Figure 3: Reference point



3.2.3.3.2. Operating conditions of the engine

3.2.3.3.2.1. Engine speed shall be held steady at one of the following values:

$\frac{1}{2}$ 50 per cent of $S n_{\text{rated}}$, if $S n_{\text{rated}}$ exceeds $5,000 \text{ min}^{-1}$

$\frac{3}{4}$ 75 per cent of $S n_{\text{rated}}$, if $S n_{\text{rated}}$ does not exceed $5,000 \text{ min}^{-1}$

where S is the engine speed at which the engine produces its maximum power n_{rated} is the rated engine speed as defined in paragraph 2.7 of this Regulation.

For a moped vehicle which cannot reach, in a stationary test, the target engine speed defined above, 95 per cent of the maximum engine speed reachable in a stationary test shall be used instead as target engine speed.

3.2.3.3.2.2. The engine speed shall be gradually increased from idle to the target engine speed and held constant within a tolerance band of ± 5 per cent. Then the throttle control shall be rapidly released and the engine speed shall be returned to idle. The sound pressure level shall be measured during a period consisting of constant engine speed of at least 1 s and throughout the entire deceleration period. The maximum sound level meter reading shall be taken as the test value.

A measurement shall be valid only if the test engine speed did not deviate from the target engine speed by more than the specified tolerance of ± 5 per cent for at least 1 s.

- 3.2.3.3.2.3. Multi-mode exhaust system
- ~~Mopeds~~ **Vehicles** equipped with a multiple mode, manually **or electronically** adjustable exhaust system shall be tested in all modes.
- 3.2.3.3.3. Result
- 3.2.3.3.3.1. Measurements shall be made at the microphone location(s) prescribed above. The maximum A-weighted sound pressure level indicated during the test shall be noted, retaining one significant figure behind the decimal place (e.g. 92.45 shall be noted as to 92.5 while 92.44 shall be noted as to 92.4). The test shall be repeated until three consecutive measurements that are within 2.0 dB(A) of each other are obtained at each outlet.
- The **test** result for a given outlet is the arithmetic average of the three valid measurements, mathematically rounded to the nearest integer value (e.g. 92.5 shall be noted as to 93 while 92.4 shall be noted as to 92).
- 3.2.3.3.3.2. For ~~mopeds~~ **vehicles** equipped with multiple exhaust outlets, the reported sound pressure level shall be for the outlet having the highest average sound pressure level.
- 3.2.3.3.3.3. For ~~mopeds~~ **vehicles** equipped with a multi-mode exhaust system and a manual **or electronic** exhaust mode control the reported sound pressure level shall be for the mode having the highest average sound pressure level.
- 4. Sound from the vehicle in motion (data reported to facilitate in motion testing of the vehicle in use).**
- 4.1. A test procedure for in use compliance tests may be defined by a Contracting Party, taking due account of any differences from the test conditions used at type approval.**
- 4.2. In order to facilitate in use compliance test of vehicles, the following information relating to the sound pressure level measurements carried out in accordance with paragraph 3.1 of Annex 3 for the vehicle in motion is referred to as in use compliance reference data:**
- (a) **Gear (i) or, for vehicles tested with non-locked gear ratios, the position of the gear selector chosen for the test;**
 - (b) **The vehicle speed v_{AA} , in km/h at the beginning of the maximum speed or full throttle acceleration test in gear (i); and**
 - (c) **The final test result in dB(A) as determined according to paragraph 3.1.4 of this annex.**
- 4.3. The in use compliance reference data shall be entered in the communication form conforming to annex 1.**

4. Interpretation of results for vehicles in motion

The values taken shall be rounded off to the nearest whole decibel. If the figure following the decimal point is between 0 and 4, the total is rounded down and if between 5 and 9, it is rounded up.

Only the values of readings obtained from two consecutive measurements made on the same side of the vehicle and not differing by more than 2 dB(A) shall be accepted.

To allow for lack of precision in the readings, the result of each measurement shall be taken as equal to the value obtained, minus 1 dB(A).

If the average of the four readings does not exceed the maximum permissible level for the category to which the tested vehicle belongs, the limit specified in paragraph 6.2.1.3. of this Regulation shall be deemed as being complied with. This average value shall constitute the test result.

Figure 1

Measuring positions for vehicles in motion

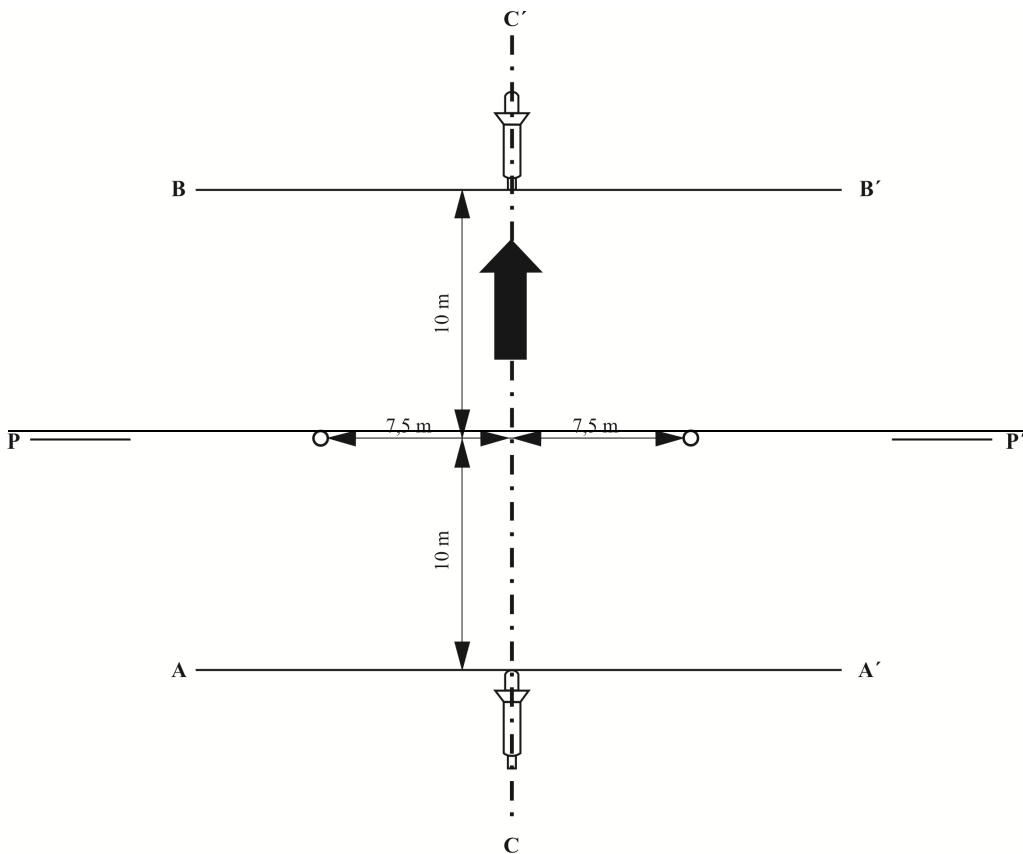
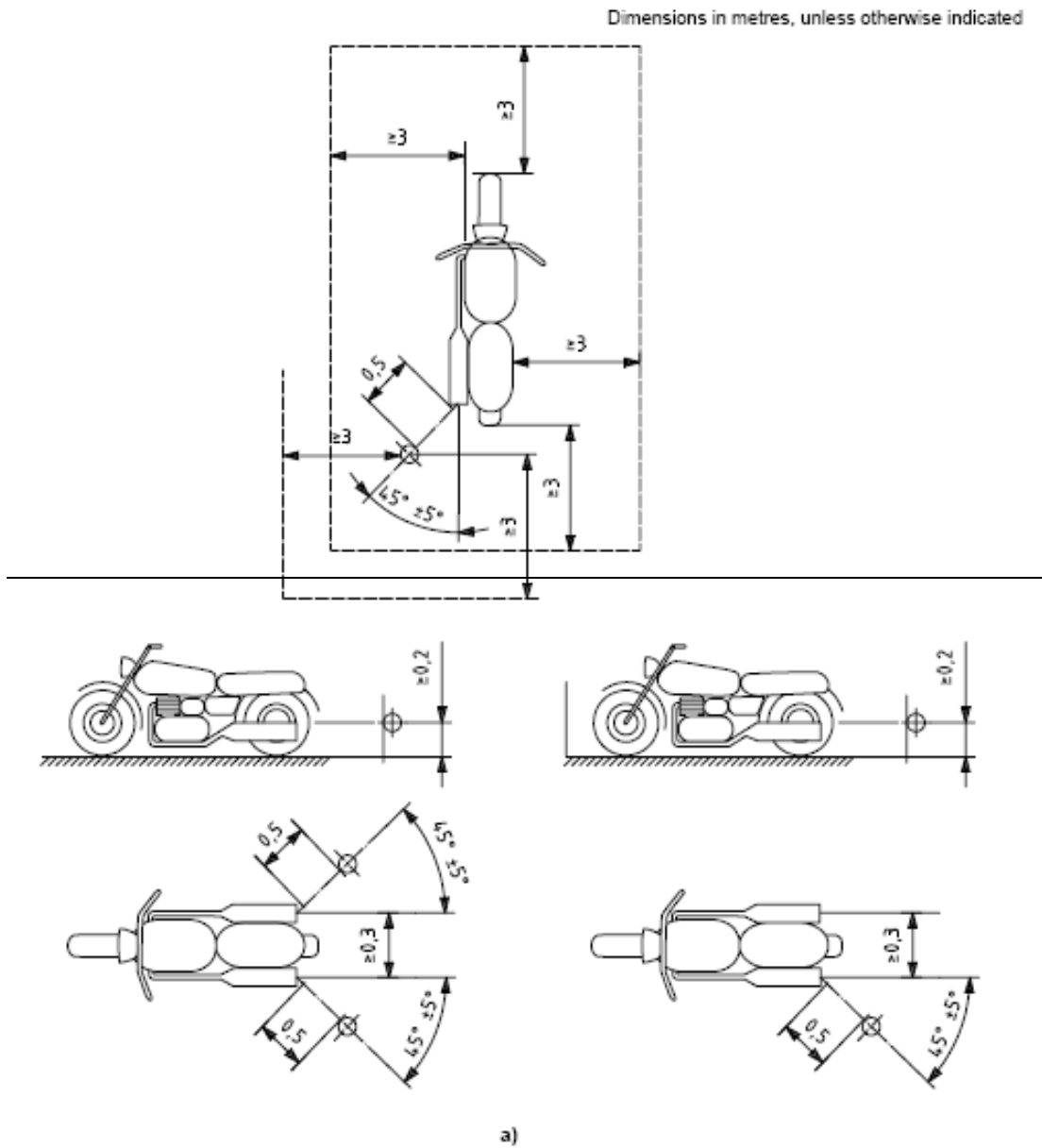

Figure 2
Measuring positions for stationary mopeds



5. Original exhaust (silencing) system
 - 5.1. Requirements for silencers containing absorbent fibrous materials.
 - 5.1.1. Fibrous absorbent material shall be asbestos-free and may be used in the construction of silencers only if suitable devices ensure that the fibrous absorbent material is kept in place for the whole time that the silencer is being used and it meets the requirements of any one of paragraphs 5.1.2., 5.1.3. or 5.1.4. below.
 - 5.1.2. After removal of the fibrous material, the sound level shall conform to the requirements of Annex 4 to this Regulation.

- 5.1.3. The fibrous absorbent material may not be placed in those parts of the silencer through which the exhaust gases pass and shall conform to the following requirements:
- 5.1.3.1. The material shall be heated at a temperature of 650 ± 5 °C for four hours in a furnace without reduction in the average length, diameter or bulk density of the fibre;
- 5.1.3.2. After heating at 650 ± 5 °C for one hour in a furnace, at least 98 per cent of the material shall be retained in a sieve of nominal aperture size 250 µm conforming to ISO 3310/1:1990/2000 when tested in accordance with ISO 2559:2000/2011;
- 5.1.3.3. The loss in weight of the material shall not exceed 10.5 per cent after soaking for 24 hours at 90 ± 5 °C in a synthetic condensate of the following composition:
- 1 N hydrobromic acid (HBr) 10 ml
- 1 N sulphuric acid (H₂SO₄) 10 ml
- Distilled water to make up to 1,000 ml
- The material shall be washed in distilled water and dried for one hour at 105 °C before weighing.
- 5.1.4. Before the system is tested in accordance with paragraph 3.1. of this annex, it shall be put into a normal state for road use by one of the following methods:
- 5.1.4.1. Conditioning by continuous road operation:
- 5.1.4.1.1. The minimum distance to be completed during conditioning shall be 2,000 km.
- 5.1.4.1.2. 50 per cent \pm 10 per cent of this conditioning cycle shall consist of town driving and the remainder of long distance runs; the continuous road cycle may be replaced by a corresponding test track programme.
- 5.1.4.1.3. The two **vehicle** speed regimes shall be alternated at least six times.
- 5.1.4.1.4. The complete test programme shall include a minimum of 10 breaks of at least three hours' duration in order to reproduce the effects of cooling and condensation.
- 5.1.4.2. Conditioning by pulsation:
- 5.1.4.2.1. The exhaust system or components thereof shall be fitted to the ~~moped~~ **vehicle** or to the engine.
- In the former case, the ~~moped~~ **vehicle** shall be mounted on a roller dynamometer. In the second case, the engine shall be mounted on a test bench.
- The test apparatus, a detailed diagram of which is shown in ~~Figure 3~~ **figure 4**, shall be fitted at the outlet of the exhaust system. Any other apparatus providing equivalent results shall be acceptable.
- 5.1.4.2.2. The test equipment shall be adjusted so that the flow of exhaust gases is alternately interrupted and restored 2,500 times by a rapid-action valve.

Figure 4: Test apparatus for conditioning by pulsation

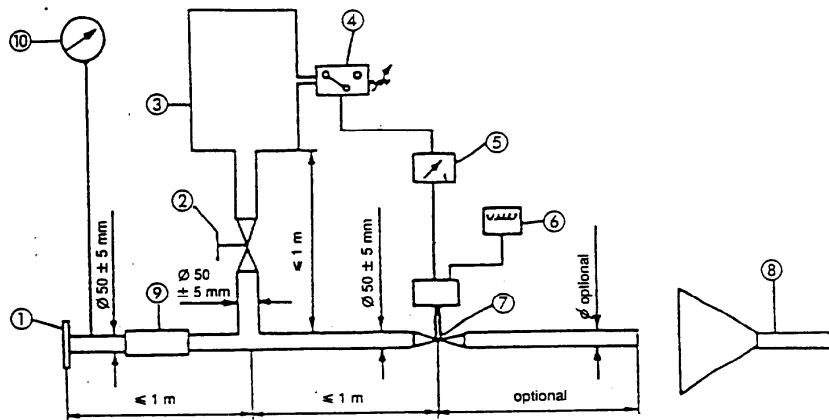

1. **Inlet flange or sleeve for connection to the rear of the test exhaust system.**
2. **Hand-operated regulating valve.**
3. **Compensating reservoir with a maximum capacity of 40 l and a filling time of not less than one second.**
4. **Pressure switch with an operating range of 5 to 250 kPa.**
5. **Time delay switch.**
6. **Pulse counter.**
7. **Quick-acting valve, such as exhaust brake valve 60 mm in diameter, operated by a pneumatic cylinder with an output of 120 N at 400 kPa. The response time, both when opening and closing, shall not exceed 0.5 second.**
8. **Exhaust gas evacuation.**
9. **Flexible pipe.**
10. **Pressure gauge**

5.1.4.2.3. The valve shall open when the exhaust gas back-pressure, measured at least 100 mm downstream of the intake flange, reaches a value of between 35 and 40 kPa. Should such a figure be unattainable because of the engine characteristics, the valve shall open when the gas back-pressure reaches a level equivalent to 90 per cent of the maximum that can be measured before the engine stops. It shall close when this pressure does not differ by more than 10 per cent from its stabilized value with the valve open.

5.1.4.2.4. The time delay switch shall be set for the duration of exhaust gases calculated on the basis of the requirements of paragraph 5.1.4.2.3. above.

5.1.4.2.5. ~~Engine speed shall be 75 per cent of the speed (S) at which the engine develops maximum power.~~ **The engine speed shall be 75 per cent of the rated engine speed as defined in paragraph 2.7 of this Regulation.**

- 5.1.4.2.6. The power indicated by the dynamometer shall be 50 per cent of the full throttle power measured at 75 per cent of ~~engine speed (S)~~ **the rated engine speed as defined in paragraph 2.7 of this Regulation.**
- 5.1.4.2.7. Any drainage holes shall be closed off during the test.
- 5.1.4.2.8. The entire test shall be completed within 48 hours. If necessary, a cooling period shall be allowed after each hour.
- 5.1.4.3. Conditioning on a test bench:
- 5.1.4.3.1. The exhaust system shall be fitted to an engine representative of the type fitted to the ~~moped vehicle~~ **for which the system is designed, and mounted on a test bench.**
- 5.1.4.3.2. Conditioning shall consist of three cycles.
- 5.1.4.3.3. Each test bench cycle shall be followed by a break of at least six hours in order to reproduce the effects of cooling and condensation.
- 5.1.4.3.4. Each test bench cycle shall consist of six phases. The engine conditions for and the duration of each phase shall be:

<i>Phase</i>	<i>Conditions</i>	<i>Duration of phase in minutes</i>
1	Idling	6
2	25 % per cent load at 75 % S per cent of n_{rated}	40
3	50 % per cent load at 75 % S per cent of n_{rated}	40
4	100 % per cent load at 75 % S per cent of n_{rated}	30
5	50 % per cent load at 100 % S per cent of n_{rated}	12
6	25 % per cent load at 100 % S per cent of n_{rated}	22
	Total time	2 h-30 min

- 5.1.4.3.5. During this conditioning procedure, at the request of the manufacturer, the engine and the silencer may be cooled in order that the temperature recorded at a point not more than 100 mm from the exhaust gas outlet does not exceed that measured when the ~~moped vehicle~~ **is running at 75 per cent of S the rated engine speed (as defined in paragraph 2.7 of this Regulation) in top gear.** The engine and/or ~~moped vehicle~~ **speeds shall be determined to within with a tolerance of ± 3 per cent.**
- 5.2. Diagram and markings
- 5.2.1. The diagram and a dimensioned cross section of the silencer shall be annexed to the documents mentioned in Annex 1 to this Regulation.
- 5.2.2 **All original silencers shall bear at least the following:**
- (a) **the ‘E’ mark followed by the reference to the country which granted the type approval;**
- (b) **the vehicle manufacturer’s name or trademark; and**
- (c) **the make and identifying part number.**
- This reference shall be legible, indelible and visible in the position at which it is to be fitted.**
- 5.2.3 **Any packaging of original replacements for exhaust or silencing systems shall be marked legibly with the words "original part" and the make and**

type reference integrated together with the "E" mark and also the reference of the country of origin.

5.3. Intake silencers

If the engine intake has to be fitted with an air filter and/or intake silencer in order to comply with the permissible sound level, the filter and/or silencer shall be regarded as part of the silencer and the requirements of paragraphs 5.1. and 5.2. above shall also be applicable to them.

Figure 3

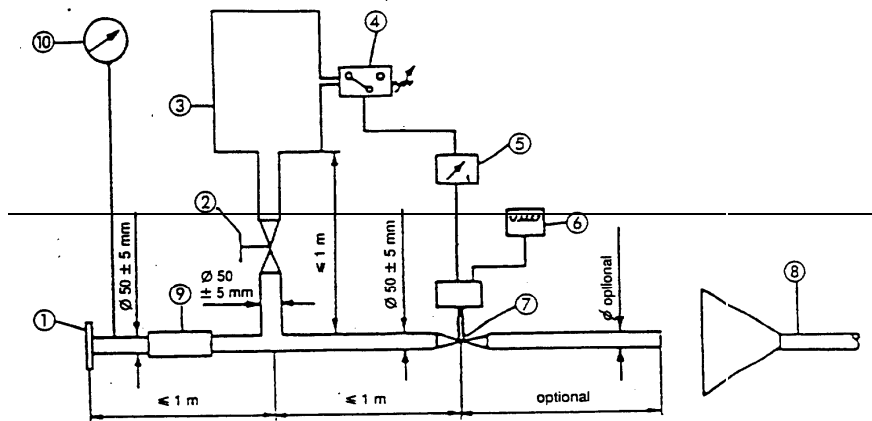

Test apparatus for conditioning by pulsation

1. ——— Inlet flange or sleeve for connection to the rear of the test exhaust system.
2. ——— Hand operated regulating valve.
3. ——— Compensating reservoir with a maximum capacity of 40 l and a filling time of not less than one second.
4. ——— Pressure switch with an operating range of 5 to 250 kPa.
5. ——— Time delay switch.
6. ——— Pulse counter.
7. ——— Quick acting valve, such as exhaust brake valve 60 mm in diameter, operated by a pneumatic cylinder with an output of 120 N at 400 kPa. The response time, both when opening and closing, shall not exceed 0.5 second.
8. ——— Exhaust gas evacuation.
9. ——— Flexible pipe.
10. ——— Pressure gauge

Figure 4
Reference point

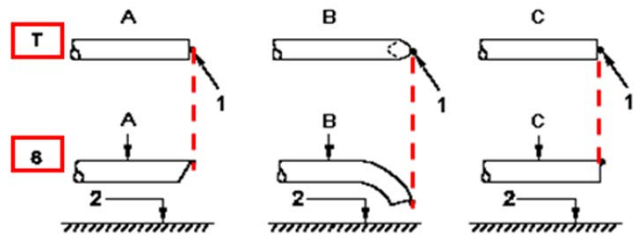

Key

T top view
S side view

1 reference point
2 road surface

A mitered pipe
B bent down pipe
C straight pipe
D vertical pipe

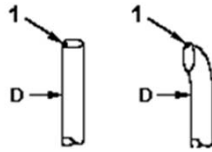

Annex 4

Maximum sound level limits (new mopeds vehicles)

<i>Category of two-wheeled mopeds</i> <i>Vehicle category</i> Maximum design speed in km/h	<i>Maximum noise – sound level values in dB(A)</i>
<u>L₁-A</u>	<u>63</u>
<u>L₁-B, v_{max} < 25 km/h</u>	66
<u>L₁-B, v_{max} > 25 km/h</u>	71

v_{max} is the maximum vehicle speed as defined in paragraph 2.12 of this regulation.

Justification: Introduction of sound emission level limits for L1-A vehicles.

Annex 5

Test track specifications¹

1. Introduction

This annex describes the specifications relating to the physical characteristics and the laying of the test track. These specifications based on a special standard² describe the required physical characteristics as well as the test methods for these characteristics.

2. Required characteristics of the surface

A surface is considered to conform to this standard provided that the texture and voids content or sound absorption coefficient have been measured and found to fulfil all the requirements of paragraphs 2.1. to 2.4. below and provided that the design requirements (paragraph 3.2. below) have been met.

2.1. Residual voids content

The residual voids content, V_C , of the test track paving mixture shall not exceed 8 per cent. For the measurement procedure, see paragraph 4.1. below.

2.2. Sound absorption coefficient

If the surface fails to conform to the residual voids content requirement, the surface is acceptable only if its sound absorption coefficient, $\alpha \leq 0.10$. For the measurement procedure, see paragraph 4.2. below. The requirements of this paragraph and paragraph 2.1. above are met also if only sound absorption has been measured and found to be $\alpha \leq 0.10$.

Note: The most relevant characteristic is the sound absorption, although the residual voids content is more familiar among road constructors. However, sound absorption needs to be measured only if the surface fails to comply with the voids requirement. This is because the latter is connected with relatively large uncertainties in terms of both measurements and relevance and some surfaces therefore may be rejected erroneously when the voids measurement only is used as a basis.

2.3. Texture depth

The texture depth (TD) measured according to the volumetric method (see paragraph 4.3. below) shall be:

$$TD \geq 0.4 \text{ mm}$$

2.4. Homogeneity of the surface

Every practical effort shall be made to ensure that the surface is made to be as homogeneous as possible within the test area. This includes the texture and voids content, but it should also be observed that if the rolling process results in more

¹ The specifications for the test site reproduced in this annex are valid until the end of the period indicated in paragraph 10.8 of this Regulation.

² ISO 10844:1994

effective rolling at some places than at others, the texture may be different and unevenness causing bumps may also occur.

2.5. Period of testing

In order to check whether the surface continues to conform to the texture and voids content or sound absorption requirements stipulated in this standard, periodic testing of the surface shall be done at the following intervals:

(a) For residual voids content or sound absorption:

When the surface is new; if the surface meets the requirements when new, no further periodical testing is required.

(b) For texture depth (TD):

When the surface is new; when the ~~noise~~ **sound** testing starts (*Note: Not before 4 weeks after laying*); then every 12 months.

3. Test surface design

3.1. Area

When designing the test track layout, it is important to ensure that, as a minimum requirement, the area traversed by the vehicles running through the test strip is covered with the specified test material with suitable margins for safe and practical driving. This will require the width of the track to be at least 3 m and the length of the track to extend beyond lines AA and BB by at least 10 m at either end. Figure 1 shows a plan of a suitable test site and indicates the minimum area which shall be machine laid and machine compacted with the specified test surface material. According to Annex 3 to this Regulation, paragraph 3.1.1.1., measurements have to be made on each side of the vehicle. This can be done either by measuring with two microphone locations (one on each side of the track) and driving in one direction, or measuring with a microphone only on one side of the track but driving the vehicle in two directions. If the latter method is used, then there are no surface requirements on that side of the track where there is no microphone.

Figure 1
Minimum requirement for test surface area. The shaded part is the "Test Area"

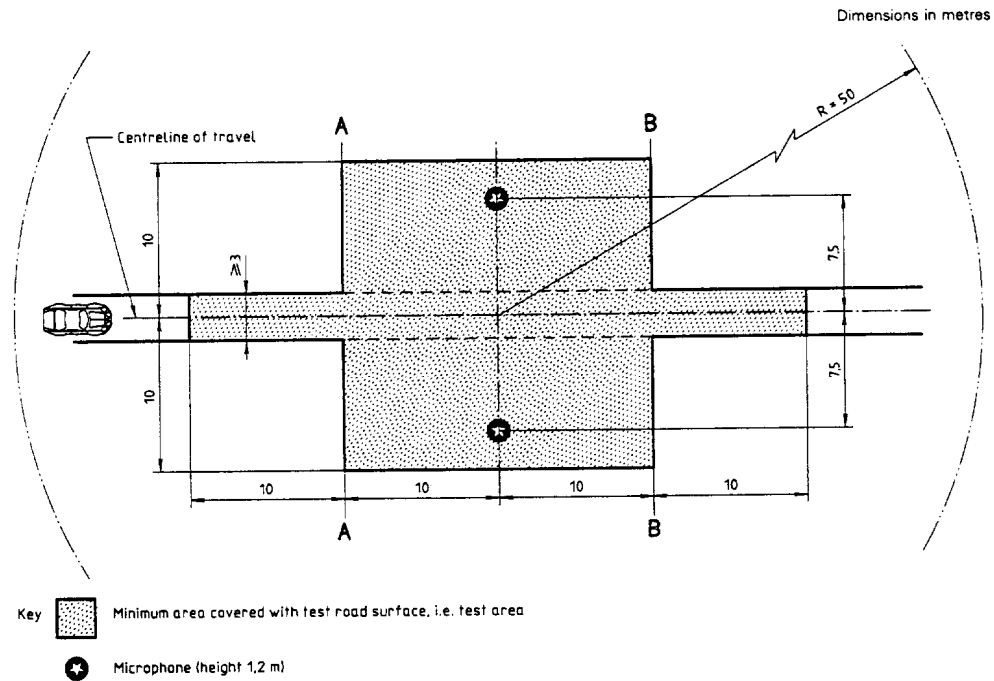

NOTE — There shall be no large acoustically reflective objects within this radius.

3.2. Design and preparation of the surface

3.2.1. Basic design requirements; the test surface shall meet four design requirements:

3.2.1.1. It shall be a dense asphaltic concrete;

3.2.1.2. The maximum chipping size shall be 8 mm (tolerances allow from 6.3 to 10 mm);

3.2.1.3. The thickness of the wearing course shall be ≥ 30 mm;

3.2.1.4. The binder shall be a straight penetration grade bitumen without modification.

3.2.2. Design guidelines

As a guide to the surface constructor, an aggregate grading curve which will give desired characteristics is shown in Figure 2. In addition, Table 1 gives some guidelines for obtaining the desired texture and durability. The grading curve fits the following formula:

$$P (\% \text{ passing}) = 100 \cdot (d/d_{\max})^{1/2}$$

where:

d = square mesh sieve size, in mm

d_{max} = 8 mm for the mean curve

d_{max} = 10 mm for the lower tolerance curve

d_{max} = 6.3 mm for the upper tolerance curve

Figure 2
Grading curve of the aggregate in the asphaltic mix with tolerances

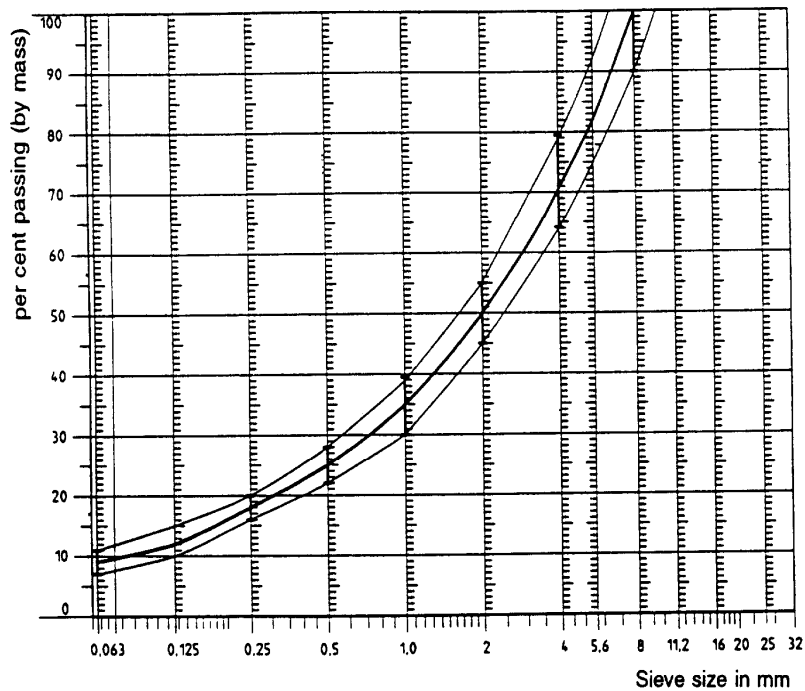

In addition to the above, the following recommendations are given:

- (a) The sand fraction ($0.063 \text{ mm} < \text{square mesh sieve size} < 2 \text{ mm}$) shall include no more than 55 per cent natural sand and at least 45 per cent crushed sand;
- (b) The base and sub-base shall ensure a good stability and evenness, according to best road construction practice;
- (c) The chippings shall be crushed (100 per cent crushed faces) and of a material with a high resistance to crushing;
- (d) The chippings used in the mix shall be washed;
- (e) No extra chippings shall be added onto the surface;
- (f) The binder hardness expressed as PEN value shall be 40-60, 60-80 or even 80-100 depending on the climatic conditions of the country. The rule is that as hard a binder as possible shall be used, provided this is consistent with common practice;
- (g) The temperature of the mix before rolling shall be chosen so as to achieve by subsequent rolling the required voids content. In order to increase the probability of satisfying the specifications of paragraphs 2.1. to 2.4. of this annex, the compactness shall be studied not only by an appropriate choice of mixing temperature, but also by an appropriate number of passings and by the choice of compacting vehicle.

Table 1
Design guidelines

Quantity	Target values		Tolerances
	by total mass of mix	by mass of the aggregate	
Mass of stones, square mesh sieve (SM) > 2 mm	47.6 %	50.5 %	±5
Mass of sand 0.063 < SM < 2 mm	38.0 %	40.2 %	±5
Mass of filler SM < 0.063 mm	8.8 %	9.3 %	±2
Mass of binder (bitumen)	5.8 %	N.A.	±0.5
Max. chipping size	8 mm		6.3 – 10
Binder hardness	(see paragraph 3.2.2. (f))		–
Polished stone value (PSV)	> 50		–
Compactness, relative to Marshall compactness	98 %		–

4. Test method

4.1. Measurement of the residual voids content

For the purpose of this measurement, cores have to be taken from the track in at least four different positions which are equally distributed in the test area between lines AA and BB (see Figure 1). In order to avoid inhomogeneity and unevenness in the wheel tracks, cores should not be taken in wheel tracks themselves, but close to them. Two cores (minimum) should be taken close to the wheel tracks and one core (minimum) should be taken approximately midway between the wheel tracks and each microphone location.

If there is a suspicion that the condition of homogeneity is not met (see paragraph 2.4. of this annex), cores shall be taken from more locations within the test area. The residual voids content has to be determined for each core, then the average value from all cores shall be calculated and compared with the requirement of paragraph 2.1. of this annex. In addition, no single core shall have a voids value which is higher than 10 per cent. The test surface constructor is reminded of the problem which may arise when the test area is heated by pipes or electrical wires and cores shall be taken from this area. Such installations shall be carefully planned with respect to future core drilling locations. It is recommended that a few locations of size approximately 200 x 300 mm should be left where there are no wires/pipes or where the latter are located deep enough in order not to be damaged by cores taken from the surface layer.

4.2. Sound absorption coefficient

The sound absorption coefficient (normal incidence) shall be measured by the impedance tube method using the procedure specified in ISO/DIS 10 534: 1994 "Acoustics - Determination of sound absorption coefficient and impedance by a tube method".

Regarding test specimens, the same requirements shall be followed as regarding the residual voids content (see paragraph 4.1 above).

The sound absorption shall be measured in the range between 400 Hz and 800 Hz and in the range between 800 Hz and 1,600 Hz (at least at the centre frequencies of third octave bands) and the maximum values shall be identified for both of these frequency ranges.

Then these values, for all test cores, shall be averaged to constitute the final result.

4.3. Volumetric macrotexture measurement

For the purpose of this standard, texture depth measurements shall be made on at least 10 positions evenly spaced along the wheel tracks of the test strip and the average value taken to compare with the specified minimum texture depth. For the description of the procedure see standard ISO 10844:1994.

5. Stability in time and maintenance

5.1. Age influence

In common with any other surfaces, it is expected that the tyre/road **noise sound** level measured on the test surface may increase slightly during the first 6-12 months after construction.

The surface will achieve its required characteristics not earlier than four weeks after construction.

The stability over time is determined mainly by the polishing and compaction by vehicles driving on the surface. It shall be periodically checked as stated in paragraph 2.5. of this annex.

5.2. Maintenance of the surface

Loose debris or dust which could significantly reduce the effective texture depth shall be removed from the surface. In countries with winter climates, salt is sometimes used for de-icing. Salt may alter the surface temporarily or even permanently in such a way as to increase **noise sound**, and is therefore not recommended.

5.3. Repaving the test area

If it is necessary to repave the test track, it is usually unnecessary to repave more than the test strip (of 3 m width in Figure 1) where vehicles are driving, provided the test area outside the strip met the requirement of residual voids content or sound absorption when it was measured.

6. Documentation of the test surface and of tests performed on it

6.1. Documentation of the test surface

The following data shall be given in a document describing the test surface:

6.1.1. The location of the test track.

6.1.2. Type of binder, binder hardness, type of aggregate, maximum theoretical density of the concrete (D_R), thickness of the wearing course and grading curve determined from cores from the test track.

6.1.3. Method of compaction (e.g. type of roller, roller mass, number of passes).

6.1.4. Temperature of the mix, temperature of the ambient air and wind speed during laying of the surface.

6.1.5. Date when the surface was laid and name of the contractor.

6.1.6. All test results or at least the latest test result, including:

6.1.6.1. The residual voids content of each core;

6.1.6.2. The locations in the test area from where the cores for voids measurements have been taken;

- 6.1.6.3. The sound absorption coefficient of each core (if measured). Specify the results both for each core and each frequency range, as well as the overall average;
 - 6.1.6.4. The locations in the test area from where the cores for absorption measurement have been taken;
 - 6.1.6.5. Texture depth, including the number of tests and standard deviation;
 - 6.1.6.6. The institution responsible for the tests according to paragraphs 6.1.6.1. and 6.1.6.2. above and the type of equipment used;
 - 6.1.6.7. Date of the test(s) and date when the cores were taken from the test track.
 - 6.2. Documentation of vehicle **noise sound** tests conducted on the surface

In the document describing the vehicle **noise sound** test(s) it should be stated whether all the requirements of this standard were fulfilled or not. Reference shall be given to a document according to paragraph 6.1. above describing the results which verify this.
-

II. Justification

1. **throughout the whole Regulation:**

The term “L₁ category vehicle” is less ambiguous than the term “two wheeled moped”, consequently the term “moped” was replaced by “vehicle” throughout the whole Regulation.

The term “noise” was replaced by “sound” throughout the whole Regulation except for background noise in order to bring it in line with other Regulations (e.g. R 41, R 51).

The term “noise made by” was replaced by “sound emitted by” in order to make the text more comprehensible.

Whenever the word “speed” is used non-specific, it was specified whether engine speed or vehicle speed is meant.

2. **Paragraph 2.2.2.**

The proposed new text is more comprehensible than the existing text.

3. **Paragraphs 2.2.3.1. to 2.5**

The sub-paragraphs 2.2.3.1 to 2.4 specifying the exhaust or silencing system, original exhaust or silencing system, non-original exhaust or silencing system, silencing systems of different types and exhaust system component were renumbered to 2.3 to 2.5, 2.8 and 2.9 in order to be more comprehensible. The current paragraph 2.3, repeating the definition of exhaust or silencing system of current paragraph 2.2.3.1, was deleted.

4. **The Paragraphs 2.6. “Rated maximum net power” and 2.7 “Rated engine speed”** were added, because rated engine speed is used in annex 3, but was not specified so far. The added footnote 2 specifies how to determine the rated engine speed in case the rated maximum net power covers an engine speed range rather than a single value.

5. **Paragraph 2.10 “reference mass”** and its sub-paragraphs and paragraph 2.9 “test mass” were added to the definitions in order to make the text in annex 3 more comprehensible.

6. **Paragraph 2.12 “maximum vehicle speed”** was added to the definitions.

The term “maximum vehicle speed” is used in annex 3 of this Regulation, but was not defined so far.

7. **Paragraph 6.2.1.2**

The text was modified in order to reflect the situation that there could be just one value instead of two values.

8. **Paragraph 6.2.1.3**

The word “measured” was replaced by “determined” in order to make the text more comprehensible.

9. Paragraph 6.3

The header was replaced by “additional requirements” and the more specific text was moved to the appropriate sub-paragraphs as headers. The added headers make the text more comprehensible.

In paragraph 6.3.1 the word “easily” was deleted in order to strengthen the requirement.

In paragraph 6.3.2. the words “or electronically” and “rider selectable” were added to cover not only manually adjustable multi-mode exhaust or silencing systems but also more advanced electronically adjustable systems.

10. Paragraph 10 Transitional provisions

The sub-paragraphs 10.7 and 10.8 were added in agreement with ECE/TRANS/WP.29/2015/64, which was already adopted by WP 29.

11. Annex 1

Point 14 “Number of gears” was renamed to “Transmission” and new sub-points 14.1 “Make”, 14.2 “Type (manual, automatic, CVT)” and 14.3 “Number of gears” were added. The existing sub-points 14.1 and 14.2 were renumbered to 14.4 and 14.5.

The existing text in point 20. was deleted in accordance with ECE/TRANS/WP.29/2015/64, but was replaced by a new point 20. “In use compliance reference data” and the sub-points 20.1 to 20.3 specifying this data. The aim is to allow not only stationary in use compliance tests but also more effective in use compliance tests with the vehicle in motion analogous to Regulation No. 41-04.

12. Annex 3, paragraph 2.1.

The whole paragraph was restructured in order to make the text more comprehensible.

Sub-paragraph 2.1.1 got the header “Test site”. Sub-paragraph 2.1.2. was integrated into sub-paragraph 2.1.1 and the text was amended according to ECE/TRANS/WP.29/2015/64.

Sub-paragraph 2.1.3 was renamed to 2.1.2 and the existing header “miscellaneous” was replaced by “Weather conditions and background noise correction”

The figure in this paragraph was deleted because it is in contradiction to table 1.

13. Annex 3, paragraph 2.2

The whole paragraph was restructured in order to make the text more comprehensible.

The header “Moped” was replaced by “Condition of the vehicle”.

The existing sub-paragraphs 2.2.3 and 2.2.4 were moved and merged to the first sub-paragraph 2.2.1 “General condition”.

The new text for the test mass specifications was placed under sub-paragraph 2.2.2.

The old sub-paragraph 2.2.2 “Tyre selection and conditions” was moved to the new sub-paragraph 2.2.3

14. Annex 3, paragraph 3

The whole paragraph was restructured in order to make the text more comprehensible.

The header 3.1.1 “General conditions of test” was replaced by “Test arrangement and microphone positions”. Figure 1 was moved from the current position to this paragraph.

The header for the new paragraph 3.1.2 “Acceleration test execution, approach vehicle speed and gear use” and the sub-paragraphs 3.1.2.1 to 3.1.2.3 are dedicated to these three issues and got corresponding headers.

The content of the existing paragraph 4 “Interpretation of results for vehicles in motion” was integrated in paragraph 3 as sub-paragraph 3.1.3, because it is exclusively dedicated to paragraph 3.1. “Interpretation of results for vehicles in motion” was replaced by “Sound level determination”, which is more comprehensible.

The calculation and rounding procedure was brought in line with the corresponding text in Regulation No. 41-04, which is more straightforward and better reflects present practice.

15. Annex 3, paragraph 3.2.3.3.1

Figures 2 and 4 were moved from the current positions to this paragraph, because they belong to this paragraph. Figure 4 was renamed to figure 3 in order to ensure the right rank order.

16. Annex 3, paragraph 3.2.3.3.2.1

S was replaced by n_{rated} in order to prevent misunderstandings, $\frac{1}{2}$ was replaced by 50 per cent and $\frac{3}{4}$ was replaced by 75 per cent in order to reflect present practice. The phrase “is engine speed at which the engine produces its maximum power” was replaced by “is the rated engine speed as defined in paragraph 2.7 of this Regulation”.

17. Annex 3, paragraph 4 (new)

A new paragraph 4 was inserted specifying the necessary data to be reported in order to facilitate in motion testing of the vehicle in use.

With regard to in use compliance tests it is well known from former research studies that stationary tests are not very effective, because there is not enough load on the engine and silencers can be constructed such as to comply with stationary tests but lead to excessive sound emissions for full load acceleration tests. It is therefore proposed to provide the data which is necessary to perform in use compliance tests according to annex 3, paragraph 3.1. This item is already implemented in Regulation No. 41-04.

18. Annex 3, paragraph 5.1.3.2

The references to the ISO standards were updated to the latest versions of the standards.

19. Annex 3, paragraph 5.1.4.2.1

Figure 3 was moved from paragraph 5.3 to this paragraph, where it belongs to and was renamed to figure 4 in order to ensure the right rank order.

20. Annex 3, paragraphs 5.1.4.2.5, 5.1.4.2.6, 5.1.4.3.4 and 5.1.4.3.5

S was replaced by n_{rated} in order to prevent misunderstandings. The phrase “engine speed at which the engine produces its maximum power” was replaced by “rated engine speed as defined in paragraph 2.7 of this Regulation” and “%” was replaced by “per cent” in order to reflect present practice.

“to within ± 3 per cent” was replaced by “with a tolerance of ± 3 per cent”

21. Annex 3, paragraph 5.2

Sub-paragraphs 5.2.2 and 5.2.3 were added in order to make tampering more difficult.

22. Annex 4

The text was improved to make it more comprehensible.

23. Annex 5

The footnote 1 was added according to ECE/TRANS/WP.29/2015/64